

3-Needle, 2/3/4-Thread Cover Stitch Sewing Machine

3本針、2 / 3 / 4本縫いカバーステッチマシン

MCS-1500N

MCS-1700N QVP

MCS-1800

PARTS LIST

HOW TO MAKE USE OF THIS PARTS LIST

- 1.As to “#01” and “#02” refer to the “Note” given at the bottom of the respective pages.
- 2.Codes on the “Qty” column
 - Each numeral indicates the number of parts required.
 - “0.1” and “2.5” indicate the length (in meters) of the respective parts.
- 3.Parentheses mean that the corresponding part is a subpart that constructs an assembly part.
- 4.Dotted lines on the Figures indicate assembly parts.

パーツリストご利用に際して

1. リストページの #01、#02 の印は、ページ下の “注記” の説明を参照下さい。
2. 数量欄の数字は、個数を表し、0.1、2.5 等の数値は、長さ（単位メートル）を表します。
3. 数量欄の（ ）は、組部品を構成している子部品であることを意味します。
4. イラストページの-----枠は、組構成であることを意味します。

CONTENTS

目次

1. FRAME COMPONENTS	1
外装関係	
2. MAIN SHAFT COMPONENTS	3
主軸関係	
3. NEEDLE BAR & PRESSER FOOT COMPONENTS	5
針棒・押え関係	
4. TENSION RELEASE COMPONENTS	7
糸調子開放機構	
5. FEED MECHANISM COMPONENTS	9
送り関係	
6. CHAIN LOOPER COMPONENTS	11
二重環関係	
7. LOOPER THREAD TENSION COMPONENTS	13
ルーパー糸調子関係	
8. NEEDLE THREAD TENSION COMPONENTS	15
針糸調子関係	
9. LAMP, MOTOR & CONTROLLER COMPONENTS	17
ランプ・モーター・コントローラ関係	
10. ACCESSORIES PARTS & OPTION COMPONENTS	19
付属品・オプション関係	
NUMERICAL INDEX OF PARTS	21
索引	

1. FRAME COMPONENTS

外装関係

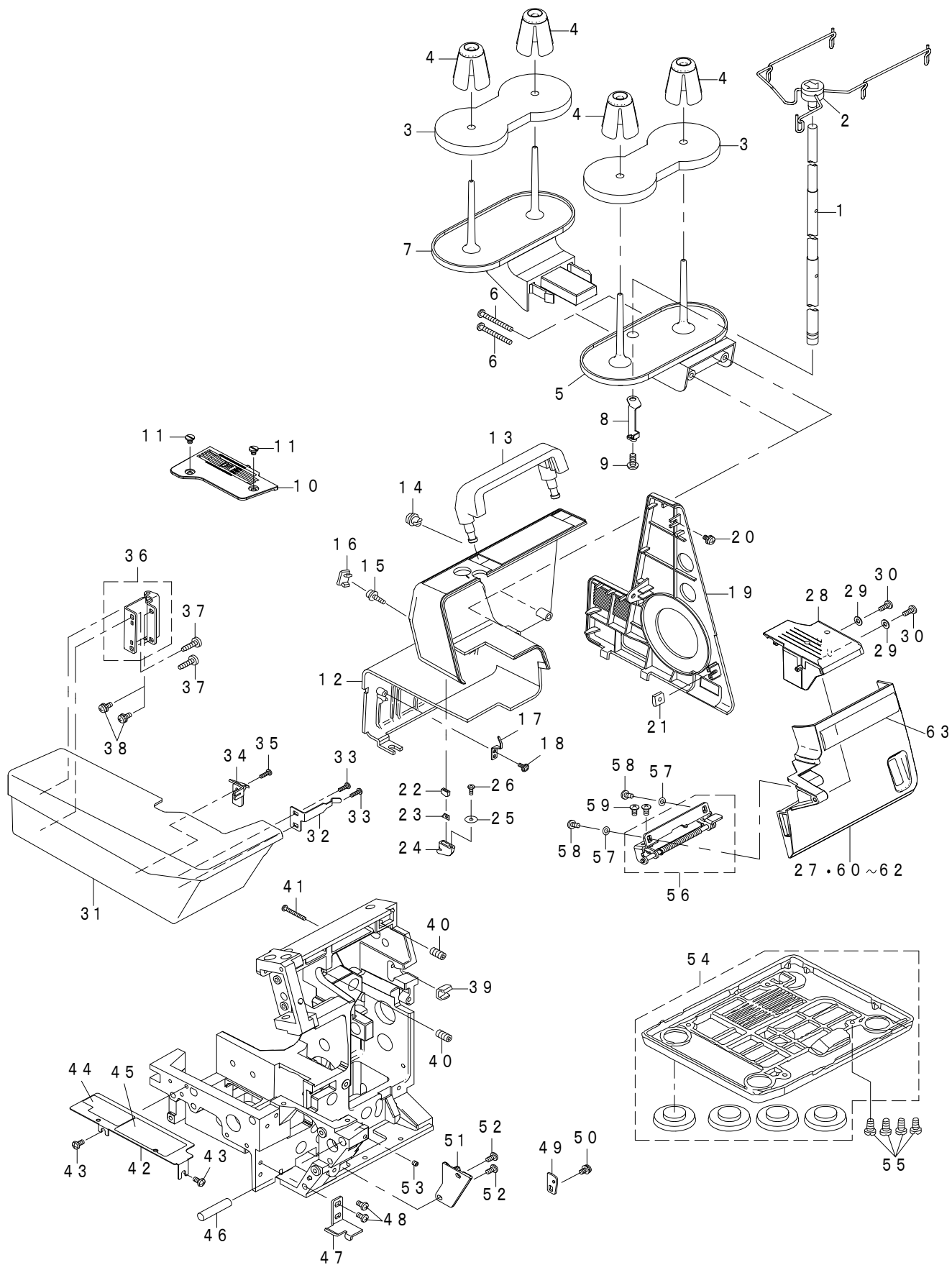

REF.NO	NOTE	PART NO	DESCRIPTION	品名	Qty
1		400-82787	THREAD_GUIDE_POST_L	糸巻き糸立棒	1
2		401-22701	ASSY_SPOOL_THREAD_GUIDE	糸立て糸案内(組)	1
3		A1121-202-000	SPOOL REST CUSHION	糸巻きシート	2
4		A1120-202-000	SPOOL RETAINER	糸巻き振れ止め	4
5		A1118-644-000-A	SPOOL HOLDER	糸立皿A	1
6		SM-5043755-SC	SCREW	糸立皿A止めねじ	2
7		A1119-644-000-A	SPOOL HOLDER (B)	糸立皿B	1
8		A1121-315-0A0-A	SPOOL HOLDER THREAD GUIDE ASM.	糸立皿糸案内(組)	1
9		SM-5051255-SN	SCREW	糸立皿糸案内止めねじ	1
10		401-22000	THROAT PLATE	針板	1
11		A1138-335-000	THROAT PLATE SETSCREW	針板止めねじ	2
12		401-74061	REAR_COVER_MCS1500	後カバー_MCS1500	1
13		A1145-523-000	HANDLE	取手	1
14		401-82063	COVER CAP	後カバーキャップA	1
15		SL-5031031-SN	SCREW	後カバー止めねじ	1
16		A1146-644-000	COVER CAP B	後カバーキャップB	1
17		A1147-535-000	THREAD GUIDE	後カバー糸案内	1
18		ST-5030851-SN	SCREW M5X8	後カバー糸案内止めねじ	1
19		A1103-C09-000	BELT COVER	側面カバー	1
20		SL-4040831-SF	SCREW M4 L=8	側面カバー止めねじ	1
21		A3151-535-000	FRONT COVER NUT	正面カバーナット	1
22		A1139-9DC-000-B	THREAD CUTTER HOLDER	糸切り刃ホルダー	1
23		A3120-031-000	THREAD CUTTER BLADE	面部糸切り刃	1
24		A1138-110-000	THR.CUTTER BASE PLATE	糸切り台	1
25		WP-0320501-SC	WASHER M3	糸切り台平座金	1
26		ST-5030851-SN	SCREW M5X8	糸切り台止めねじ	1
27		401-74063	LOOPER_COVER_MCS1500	ルーパーカバー_MCS1500	1
28		401-21988	SUPPORT BED ASSY	補助ベッド(結合)	1
29		WP-0430801-SC	WASHER M4	補助ベッド平座金	2
30		ST-5041051-SN	SCREW	補助ベッド止めねじ	2
31		A1104-523-000-A	CLOTH PLATE	布台	1
32		A1160-524-000	CLOTH PLATE STOPPER SPRING	布台ストッパーばね	1
33		ST-5031051-SN	TAPPING SCREW	布台ストッパーばね止めねじ	2
34		A2154-9DC-000	RELEASE PLATE	二重環リリース受板	1
35		ST-5031051-SN	TAPPING SCREW	二重環リリース受板止めねじ	1
36		A1161-535-0A0	CLOTH PLATE HINGE ASM.	布台ヒンジ(組)	1
37		ST-5041051-SN	SCREW	布台止めねじ	2
38		SL-4040855-SN	SCREW M4 L=8	布台ヒンジ止めねじ	2
39		A3150-535-000	FRONT COVER ASM. PLATE	正面カバー固定板	1
40		SM-8050842-TP	SETSCREW	取手止めねじ	2
41		SM-5032555-SE	SCREW M3 L=25	正面カバー固定板止めねじ	1
42		A1135-535-000	OP COVER	上カバー	1
43		SM-5040855-SN	SCREW	上カバー止めねじ	2
44		A9196-524-000	CAUTION LABEL	注意ラベル	1
45		401-22010	LOOPER_THREADING_CHART	ルーパー糸通し図	1
46		A4125-655-000	GUIDE SHAFT	下メスホルダー案内軸	1
47		A1164-535-000	CLOTH PLATE PRESSER PLATE (G)	布台押え板	1
48		SM-5040855-SN	SCREW	布台押え板止めねじ	2
49		A2538-554-000	PLATE	下ルーパー糸案内レバープレート	1
50		SL-4040855-SN	SCREW M4 L=8	下ルーパー糸案内レバープレート止めねじ	1
51		A1156-523-000	LOOPER_COVER_GUIDE	ルーパーカバーガイド	1
52		SM-4040855-SN	SCREW M4 L=8	ルーパーカバーガイド止めねじ	2
53		SM-8040402-TP	SCREW M4X0.7 L=4	下メスホルダー案内軸止めねじ	2
54		A1102-523-0A0-A	BASE PLATE ASM.	底板(組)	1
55		SM-5051255-SN	SCREW	底板止めねじ	4
56		A1153-503-0AC	LOOPER_COVER_HINGE_ASM.	ルーパーカバーヒンジ(組)	1
57		WP-0430801-SC	WASHER M4	ルーパーカバーヒンジ平座金	2
58		ST-5041051-SN	SCREW	ルーパーカバーヒンジ止めねじ	2
59		SM-5040855-SN	SCREW	ルーパーカバー止めねじ	2
60	#01	401-97624	LOOPER_COVER_MCS1700	ルーパーカバー_MCS1700	1
61	#02	402-14126	LOOPER_COVER_MCS1800	ルーパーカバー_MCS1800	1
62	#03	401-21986	LOOPER_COVER	ルーパーカバー	1
63	#03	402-14133	EMBLEM_MCS1500N	エンブレムMCS1500N	1
		NOTE(注記)	#01....FOR MCS-1700N QVP #02....FOR MCS-1800 #03....FOR JP	MCS-1700N QVP 用 MCS-1800用 JP 用	

2. MAIN SHAFT COMPONENTS

主軸關係

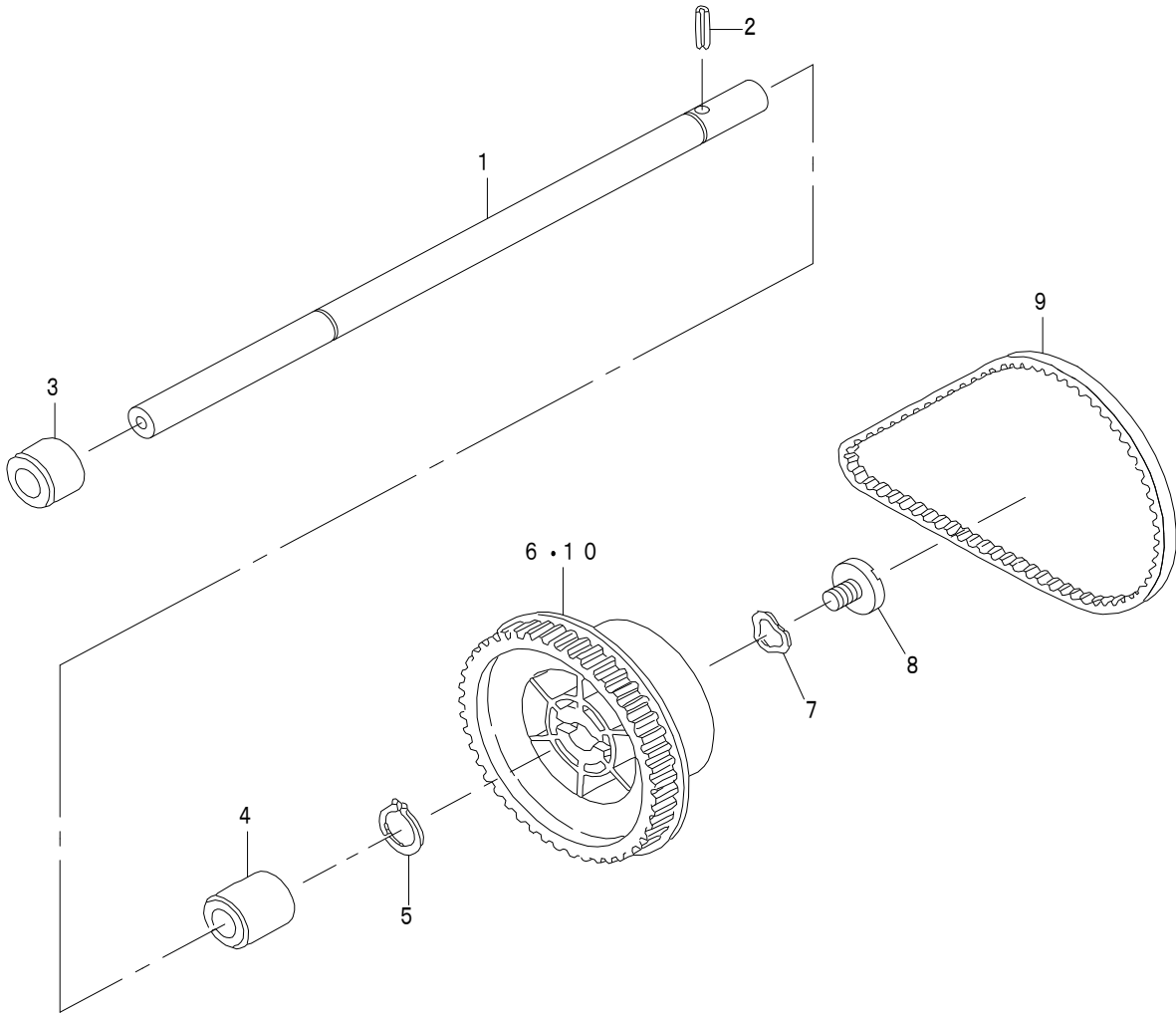

REF.NO	NOTE	PART NO	DESCRIPTION	品名	Qty
1		400-71774	MAIN SHAFT	主軸	1
2		PS-0400222-KP	SPRING PIN	はずみ車止固定ピン	1
3		A1206-335-000	MAIN SHAFT BUSHING FRONT	主軸前メタル	1
4		A1206-202-000	MAIN SHAFT BUSHING	主軸後メタル	1
5		A1206-102-000	C RING	主軸Cリング	1
6		A1202-113-000	HAND WHEEL	はずみ車	1
7		A1206-535-000	HANDWHEEL WASHER	主軸波座金	1
8		A1230-500-000-A	HANDWHEEL SETSCREW	はずみ車止めねじ	1
9		A1205-634-000	TIMING BELT	主軸駆動ベルト	1
10	#01	401-97629	HANDWHEEL_QVP	はずみ車QVP	1
		NOTE(注記)	#01....FOR MCS-1700N QVP, MCS-1800	MCS - 1700 N QVP, MCS - 1800用	

3. NEEDLE BAR & PRESSER FOOT COMPONENTS

針棒・押え関係

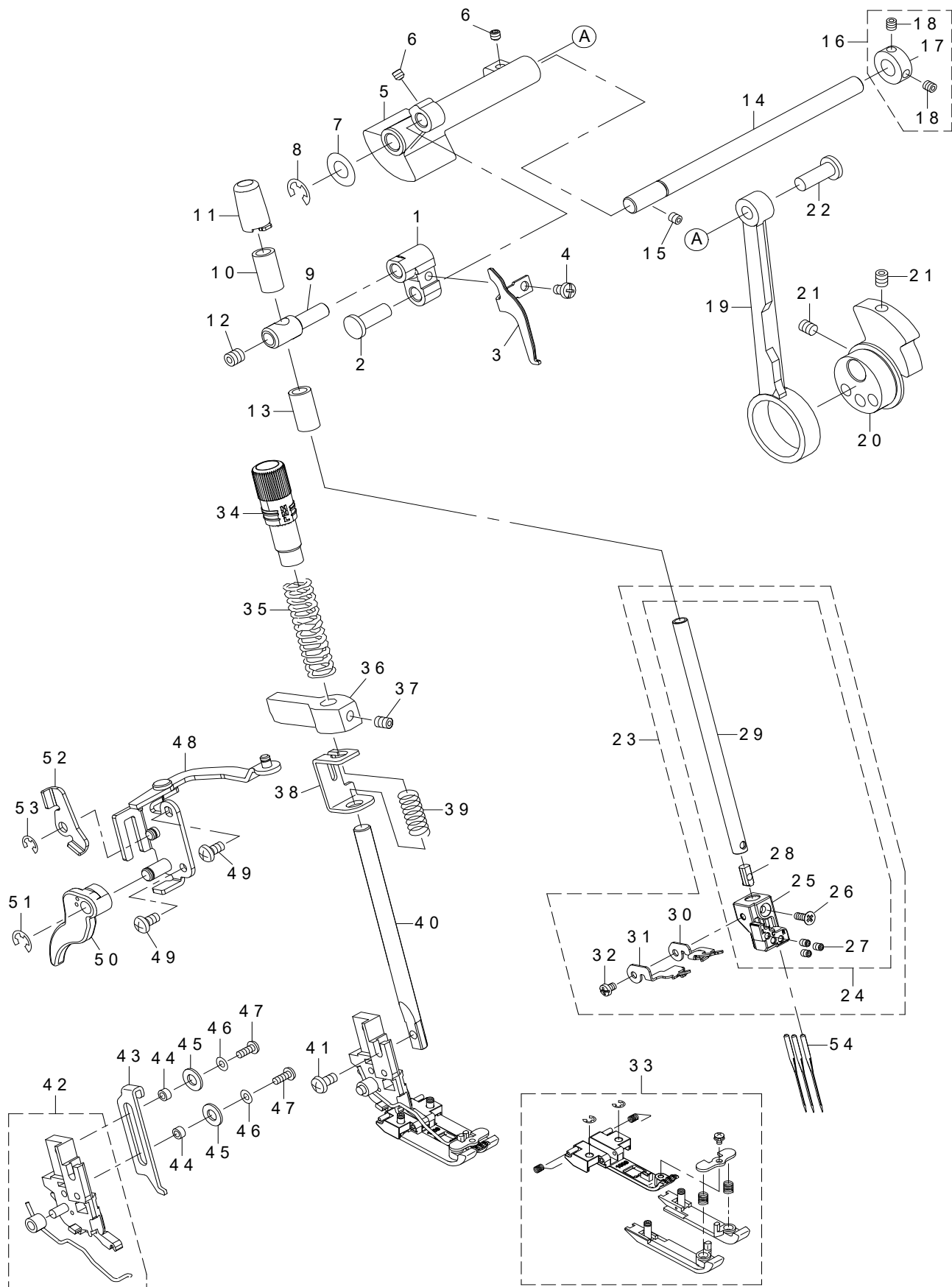

REF.NO	NOTE	PART NO	DESCRIPTION	品名	Qty
1		A1412-535-000	NEEDLE BAR LINK	針棒リンク	1
2		A1403-102-000	CONNECTING PIN	連結ピン	1
3		A1412-130-000	NEEDLE THREAD TAKE-UP	針糸天秤	1
4		SM-5030555-SC	SCREW	針糸天秤止めねじ	1
5		A1402-535-000	NEEDLE BAR CRANK	針棒クランク	1
6		SM-8040402-TP	SCREW M4X0.7 L=4	針棒クランク止めねじ	2
7		WP-0820516-SP	WASHER 11.6X8.2X0.6	針棒駆動軸平座金	1
8		RE-0600000-K0	E-RING 6	針棒駆動軸止めEリング	1
9		A1411-335-000	CLOTH PLATE FIXING SPRING	針棒抱き	1
10		A1407-102-000	NEEDLE BAR BUSHING, LOWER	針棒下メタル	1
11		A1415-523-000	NEEDLE BAR CAP	針棒キャップ	1
12		SM-8060602-TP	SCREW M6X6	針棒下メタル止めねじ	1
13		A1407-102-000	NEEDLE BAR BUSHING LOWER	針棒下メタル	1
14		A1404-535-000	NEEDLE BAR DRIVING SHAFT	針棒駆動軸	1
15		SM-8040402-TP	SCREW M4X0.7 L=4	連結ピン止めねじ	1
16		A1414-502-0A0	THRUST COLLAR ASM.	ルーバー軸スラストカラー (組)	1
17		A1414-502-000	THRUST COLLAR	スラストカラー	(1)
18		SM-8040402-SP	SCREW	スラストカラー止めねじ	(2)
19		A1403-335-000-A	NEEDLE BAR CRANK ROD	針棒クランクロッド	1
20		A1401-535-000-A	NEEDLE BAR DRIVING CAM	針棒駆動カム	1
21		SM-8050602-TP	SCREW M5 L=6	針棒駆動カム止めねじ	1
22		A1403-102-000	CONNECTING PIN	連結ピン	1
23		401-21997	ALL_ASSY_NEEDLE BAR	針棒 (総組)	1
24		401-21998	ASSY_NEEDLE BAR	針棒 (組)	(1)
25		401-21999	NEEDLE_CLANP	針留め	(1)
26		SM-1030801-SN	SCREW M3X0.5 L=8	針留め止めねじ	(1)
27		401-25265	SCREW_M3X5	針止めねじ	(3)
28		401-23324	NEEDLE_BAR_STOPPER	針棒ストッパー	(1)
29		401-23323	NEEDLE_BAR	針棒	(1)
30		401-21972	NEEDLE BAR THREAD GUIDE	針棒糸案内	(1)
31		401-27196	NEEDLE BAR THREAD GUIDE_B	針棒糸案内B	(1)
32		SM-4030455-SN	SCREW	針棒糸案内止めねじ	(1)
33		401-22001	ALL ASSY COVER STITCH FOOT	カバーリング押え (総組)	1
34		401-39206	PRESSER_ADJUST_SCREW	押え圧調整ねじ	1
35		401-25609	PRESSER_SPRING	押え調節ばね	1
36		A1502-C09-000	PRESSER BAR GUIDE BRACKET	押え棒抱き	1
37		SM-8050402-TP	SCREW	押え棒抱き止めねじ	1
38		A1522-110-000	PRESSER LIFT PLATE	押え浮かし台	1
39		A1523-110-000	SPRING	押え浮かし台戻しばね	1
40		A1507-C09-000	PRESSER BAR	押え棒	1
41		SM-5040855-SN	SCREW	押え足止めねじ	1
42		A1514-C09-0B0-B	PRESSER FOOT SHANK ASM.	押え足 (組)	1
43		A1520-130-000	LINK	押え浮かしリンク	1
44		A1521-110-00C	PRESSER FLOAT LINK COLLAR	押え浮かしリンクカラー	2
45		WP-0531001-SC	WASHER M5	押え浮かしリンク平座金	2
46		WP-0320501-SC	WASHER M3	押え浮かしリンク平座金	2
47		SM-5030855-SN	SCREW	押え浮かしリンク止めねじ	2
48		A1504-9DC-0B0	HANDLIFTING LEVER INSTLLING BASE ASM.	押え上げレバー取付台 (総組)	1
49		SM-4040855-SN	SCREW M4 L=8	押え上げレバー取付台止めねじ	2
50		401-27201	LIFTING LEVER	押え上げレバー	1
51		RE-0500000-K0	E-RING	押え上げレバー止めEリング	1
52		A1572-9DC-000	THR.TENS.RELEASE DRIVING ARM	血浮し駆動腕	1
53		RE-0400000-K0	E-RING 4	血浮し駆動腕止めEリング	1
54		MC-2215008-00	NEEDLE(130/705H 15X1H)#80	針 130/705H 15X1H NM80	3

4. TENSION RELEASE COMPONENTS

糸調子開放機構

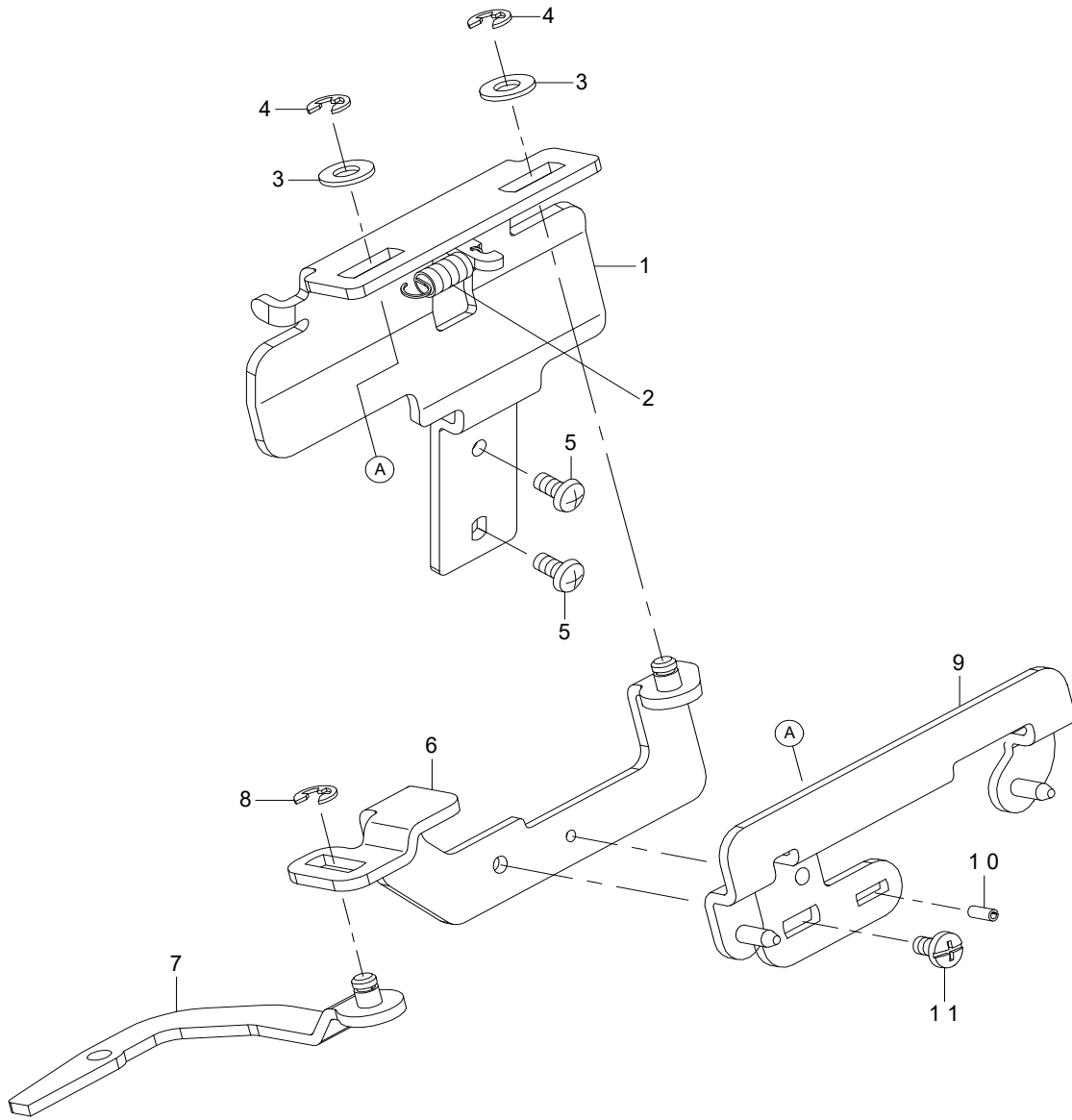

REF.NO	NOTE	PART NO	DESCRIPTION	品名	Qty
1		A1578-9DC-000	THR TENS REL MOVING LINK BASE	皿浮し作動リンク取付台	1
2		A1577-9DC-000	SPRING	皿浮し作動リンク戻しばね	1
3		WP-0430801-SC	WASHER M4	皿浮し作動リンク平座金	2
4		RE-0300000-K0	E-RING 3	皿浮し作動リンク止めEリング	2
5		SM-5030655-SF	SCREW M3 L=6	皿浮し作動リンク止めねじ	2
6		401-21981	THR TENS RELEASE ADJ ARM ASSY	皿浮し調節腕 (結合)	1
7		A1573-9DC-0A0	THR TENS RELEASE LINK ASM.	皿浮しリンク (組)	1
8		RE-0300000-K0	E-RING 3	皿浮しリンク止めEリング	1
9		401-21983	THR TENS REL MOVING LINK ASSY	皿浮し作動リンク (結合)	1
10		PS-0200052-KP	SPRING PIN TYPE W 2X5	皿浮し作動リンク固定ピン	1
11		SM-5030655-SF	SCREW M3 L=6	皿浮し作動リンク止めねじ	1

5. FEED MECHANISM COMPONENTS

送り関係

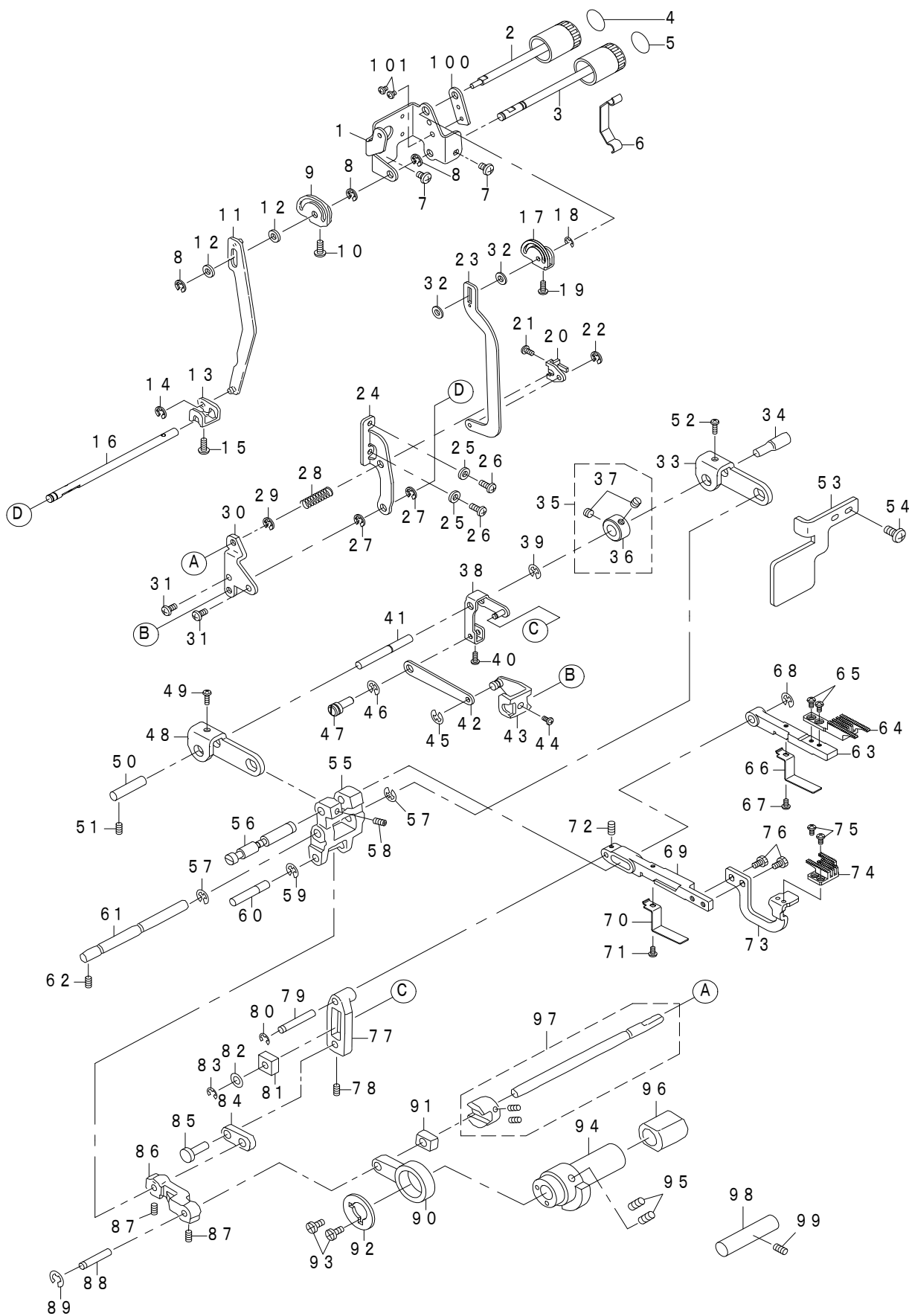

REF.NO	NOTE	PART NO	DESCRIPTION	品名	Qty
1		A1610-9DC-000	ADJUSTING KNOB BASE PLATE	送りつまみ取付板	1
2		A1601-556-D00-B	MAIN FEED ADJUSTING KNOB	水平送り調節つまみ	1
3		A1602-534-D00-B	DIFFERENTIAL FEED ADJUSTING KNOB	副送り調節つまみ	1
4		A1603-65D-E00	SEAL	水平送りつまみラベル	1
5		A1604-534-D00-A	LABEL DIFFERENTIAL FEED	副送りつまみラベル	1
6		A1611-655-000	KNOB HOLDING PLATE	送りつまみ軸押え板	1
7		SM-5040655-SN	SCREW	送りつまみ取付板止めねじ	2
8		RE-0400000-K0	E-RING 4	副送り調節つまみ止めEリング	3
9		A1615-534-D00	DIFFERENTIAL FEED ADJUSTING CAM	副送り調節カム	1
10		SM-5030855-SN	SCREW	副送り調節カム止めねじ	1
11		A1620-534-DA0	DIFFERENTIAL FEED ADJUSTING LINK ASM.	副送り調節リンク (B) (組)	1
12		A1614-534-D00	COLLAR	調節カムスラストカラー	2
13		A1655-534-D00	DIFFERENTIAL FEED ADJUSTING ARM C	副送り調節腕 (C)	1
14		RE-0300000-K0	E-RING 3	副送り調節腕 (C) 止めEリング	1
15		SM-5030655-SN	SCREW M3X0.5 L=6	副送り調節軸止めねじ	1
16		A1662-655-000-A	SHAFT	副送り調節軸	1
17		A1613-655-000	MAIN FEED ADJUSTING CAM	水平送り調節カム	1
18		RE-0400000-K0	E-RING 4	水平送り調節つまみ止めEリング	1
19		SM-5030855-SN	SCREW	水平送り調節カム止めねじ	1
20		A1630-534-D00	MAIN FEED ADJUSTING ARM	水平送り調節腕	1
21		SM-5030655-SN	SCREW M3X0.5 L=6	水平送り調節軸止めねじ	1
22		RE-0300000-K0	E-RING 3	水平送り調節軸止めEリング	1
23		A1619-655-0A0	MAIN FEED ADJUSTING LINK ASM.	水平送り調節リンク(組)	1
24		A1634-655-000-A	FEED ADJ.SHAFT SUPPORT PLATE	送り調節軸取付板	1
25		WP-0430801-SC	WASHER M4	送り調節軸取付板平座金	2
26		SM-5041055-SN	SCREW M4X10	送り調節軸取付板止めねじ	1
27		RE-0500000-K0	E-RING 5	副送り調節軸止めEリング	2
28		A1633-534-D00	SPRING	送り調節器押えばね	1
29		RE-0500000-K0	E-RING 5	送り調節器押えばね止めEリング	1
30		A1635-534-D00	FEED ADJUSTING BEARING	送り調節軸受	1
31		SM-5041055-SN	SCREW M4X10	送り調節軸受止めねじ	1
32		A1614-655-000	WASHER	水平送り調節カム座金	2
33		A1660-534-D00-A	DIF.FEED SHAFT HOLDER	副送り軸受	1
34		A1664-655-000	DIFFERENTIAL FEED SHAFT B	副送り軸 (B)	1
35		A1663-776-0A0	FULCRUM SHAFT COLOR ASM.	副送り調節腕 (A) 支点軸カラー (組)	1
36		A1663-776-000	FULCRUM SHAFT COLOR	副送り調節腕 (A) 支点軸カラー	(1)
37		SM-8030302-TP	SCREW M3X0.5 L=3	副送り調節腕 (A) 支点軸カラー止めねじ	(2)
38		A1661-800-0A0	DIFFERENTIAL FEED ADJUSTING ARM A ASM.	副送り調節腕 (A) 組	1
39		RE-0500000-K0	E-RING	副送り調節腕支点軸止めEリング	1
40		SM-5030855-SN	SCREW	副送り調節リンク (A) 偏心ピン止めねじ	1
41		A1659-534-D00-A	SHAFT	副送り調節腕支点軸	1
42		A1653-776-000	DIF.FEED ADJUSTING LINK A	副送り調節リンク (A)	1
43		A1657-534-DA0	DIF.FEED ADJUSTING ARM B ASM.	副送り調節腕 (B) 組	1
44		SM-5030655-SN	SCREW M3X0.5 L=6	副送り調節軸止めねじ	1
45		RE-0300000-K0	E-RING 3	副送り調節腕 (B) 止めEリング	1
46		RE-0500000-K0	E-RING 5	副送り調節リンク (A) 偏心ピン止めEリング	1
47		A1654-776-000-A	ECCENTRIC PIN	副送り調節リンク (A) 偏心ピン	1
48		A1660-534-D00-A	DIF.FEED SHAFT HOLDER	副送り軸受	1
49		SM-5031001-SE	SCREW M3 L=10	副送り軸受止めねじ	1
50		A1663-534-D00	DIF.FEED SHAFT A	副送り軸 (A)	1
51		SM-8040402-TP	SCREW M4X0.7 L=4	副送り軸 (A) 止めねじ	1
52		SM-5031001-SE	SCREW M3 L=10	副送り軸受止めねじ	1
53		A1613-535-000	FEED BASE GUIDE PLATE	送り台ガイド板	1
54		SM-4040655-SN	SCREW M4X0.7 L=6	送り台ガイド板止めねじ	1
55		A1645-534-D00	MAIN FEED ARM	水平送り腕	1
56		A1646-534-D00	BASE SUPPORTING SHAFT	送り台支え軸	1
57		RE-0500000-K0	E-RING	水平送り軸止めEリング	1
58		SM-8040402-TP	SCREW M4X0.7 L=4	送り台支え軸止めねじ	1
59		RE-0400000-K0	E-RING 4	水平送りリンク軸止めEリング	1
60		A1641-534-D00	SHAFT	水平送りリンク軸	1
61		A1647-534-D00	MAIN FEED SHAFT	水平送り軸	1
62		SM-8040402-TP	SCREW M4X0.7 L=4	水平送り軸止めねじ	1
63		A1625-800-000	FEED BASE	送り台	1
64		A1627-C09-000	MAIN FEED DOG	主送り歯	1
65		SM-4030655-SP	SCREW	主送り歯止めねじ	1
66		A1616-030-Z00	SPRING	水平送りロットばね	1
67		SM-4030655-SP	SCREW	水平送りロットばね止めねじ	1
68		RE-0500000-K0	E-RING	送り台支え軸止めEリング	1
69		A1639-800-000	DIFFERENTIAL FEED BASE	副送り台	1
70		A1616-030-Z00	SPRING	水平送りロットばね	1
71		SM-4030655-SP	SCREW	水平送りロットばね止めねじ	1
72		SM-8030302-TP	SCREW M3X0.5 L=3	副送り台止めねじ	1
73		A1648-655-000	DIFFERENTIAL FEED DOG FITTING BASE	副送り歯取付板	1
74		A1642-C09-000	DIFFERENTIAL FEED DOG	副送り歯	1
75		SM-4030655-SP	SCREW	副送り歯止めねじ	2
76		SM-9040700-SP	HEXAGONAL BOLT	副送り歯取付板止めねじ	2
77		A1651-534-D00	DIFFERENTIAL FEED ARM	副送り腕	1
78		SM-8030402-TP	SCREW M3X0.5 L=4	副送り腕止めねじ	1
79		A1665-534-D00	SHAFT	副送り台連結軸	1
80		RE-0300000-K0	E-RING 3	副送り台連結軸止めEリング	1
81		A1652-534-D00	DIFFERENTIAL FEED SLIDE BLOCK	副送り角駒	1
82		WP-0430801-SC	WASHER M4	副送り角駒平座金	1
83		RE-0300000-K0	E-RING 3	副送り角駒止めEリング	1
84		A1650-534-D00	DIFFERENTIAL FEED LINK	副送りリンク	1
85		A2529-335-000	UPPER LOOPER ARM PIN	上ルーパ腕ピン	1
86		A1640-534-D00	MAIN FEED LINK	水平送りリンク	1
87		SM-8030402-TP	SCREW M3X0.5 L=4	水平送りリンク止めねじ	1
88		A1639-534-D00	SHAFT	水平送り角駒軸	1
89		RE-0400000-K0	E-RING 4	水平送り角駒軸止めEリング	1
90		A1616-534-D00	MAIN FEED ROD	水平送りロッド	1
91		A1638-776-000	MAIN FEED MAIN FEED	水平送り角駒	1
92		A1618-534-D00	THRUST PLATE	水平送りスラスト板	1
93		A1618-534-DA0	SCREW	水平送りスラスト板止めねじ	2
94		A1617-534-D00-A	MAIN FEED CAM	水平送りカム	1
95		SM-8040612-TP	SCREW M4 L=6	水平送りカム止めねじ	2
96		A1630-535-000	VERTICAL FEED SLIDE BLOCK	上下送り角駒	1
97		A1637-534-DA0	FEED REGULATOR ASM.	水平送り調節器 (組)	1
98		A1612-535-000	FEED BASE GUIDE ROD	送り台ガイド軸	1
99		SM-8040402-TP	SCREW M4X0.7 L=4	送り台ガイド軸止めねじ	1
100		401-72181	KNOB_ADJUSTING_PLATE	送りつまみ軸調節板	1
101		SM-5030455-SF	SCREW M3 L=4	パイント小ねじ M3 L=4	2

6. CHAIN LOOPER COMPONENTS

二重環關係

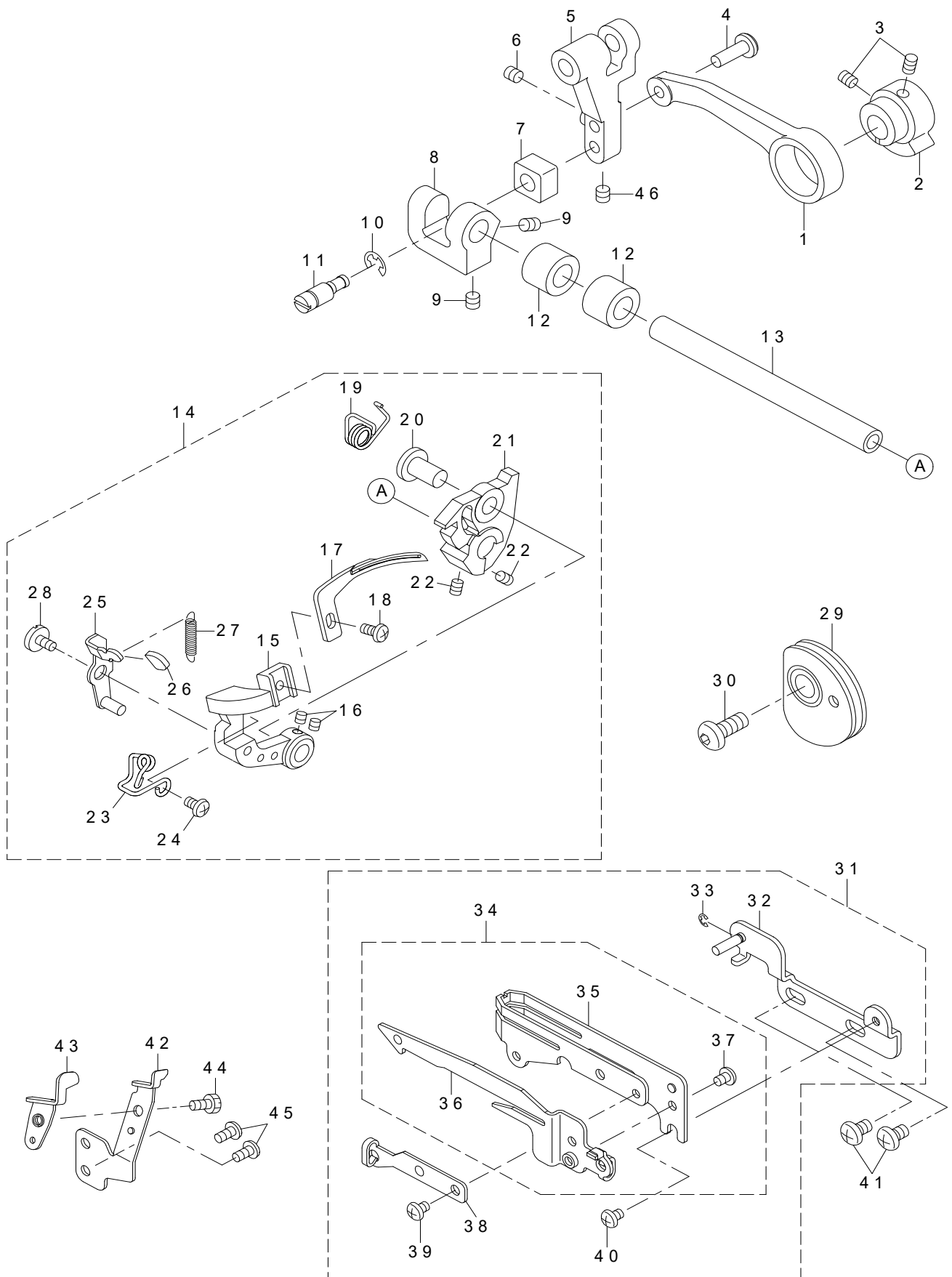

REF.NO	NOTE	PART NO	DESCRIPTION	品名	Qty
1		A2105-535-000	CHAIN STITCHING LENGTHWISE	二重環前後ロッド	1
2		A2103-9DC-000	DOUBLE-CHAIN OSC.CAM	二重環前後カム	1
3		SM-8040412-TP	SET SCREW M4 L=4	二重環前後カム止めねじ	2
4		A2529-335-000	UPPER LOOPER ARM PIN	上ルーバー腕ピン	1
5		A2114-535-000	CHAIN STITCHING LENGTHWISE	二重環前後支持腕	1
6		SM-8040402-TP	SCREW M4X0.7 L=4	二重環前後支持腕止めねじ	1
7		A2116-535-000	CHAIN STITCHING SLIDING BLOCK	二重環角駒	1
8		A2113-535-000-A	CHAIN STITCHING HOLD BLOCK	二重環角駒抱き	1
9		SM-8040402-TP	SCREW M4X0.7 L=4	二重環角駒抱き止めねじ	2
10		RE-0400000-K0	E-RING 4	二重環角駒軸止めEリング	1
11		A2115-655-000	CHAIN STITCHING SLIDING BLOCK	二重環角駒軸	1
12		A1675-335-000	HORI. FEED SHAFT METAL FRONT	水平送り軸前メタル	2
13		A2107-655-000	CHAIN LOOPER SHAFT	二重環軸	1
14		401-22704	ALL_ASSY_DOUBLE_CHAIN_LOOPER	二重環ルーバー (総組)	1
15		A2151-9DC-000-A	D-CHAIN LOOPER SUPPORTING ARM A	二重環ルーバー支持腕A	(1)
16		SM-8030302-TP	SCREW M3X0.5 L=3	二重環ルーバー支持腕A止めねじ	(2)
17		A2109-9DC-000	D-CHAIN LOOPER	二重環ルーバー	(1)
18		SM-5030655-SN	SCREW M3X0.5 L=6	二重環ルーバー止めねじ	(1)
19		A2158-655-000	SPRING	二重環ルーバー支持腕戻しばね	(1)
20		A2155-655-000-A	D-CHAIN LOOPER SUPPORTING SHAFT	二重環ルーバー支持軸	(1)
21		A2152-9DC-000	D-CHAIN LOOPER SUPP.ARM B	二重環ルーバー支持腕B	(1)
22		SM-8040602-TP	SCREW M4X0.7 L=6	二重環ルーバー支持腕B止めねじ	(2)
23		A2165-9DC-000	LOOPER MIDDLE THREAD GUIDE	ルーバー中間糸案内	(1)
24		SM-5030555-SC	SCREW	ルーバー中間糸案内止めねじ	(1)
25		A2153-655-0A0	D-CHAIN LOOPER SUPP.ARM LATCH ASM.	二重環支持腕ラッチ (組)	(1)
26		A1167-315-00A-A	THREAD SLIPPER CAP	糸滑片キャップ	(1)
27		A2159-655-000	SPRING	二重環ラッチばね	(1)
28		A2156-655-000	SCREW	ラッチ支点ねじ	(1)
29		401-21975	CHAIN LOOPER TAKE UP ASSY	二重環ルーバー天秤 (結合)	1
30		A2138-335-000	SCREW	二重環ルーバー止めねじ	1
31		A2130-9DC-0B0	LOOPER TAKE-UP GUIDE MAS.ASM.	二重環天秤ガイド (総組)	1
32		A2132-655-0A0	D-CHAIN LOOP.TATE-UP BASE PLATE ASM.	二重環天秤台板 (組)	(1)
33		RE-0200000-K0	E-RING 2	二重環天秤台板止めEリング	(1)
34		A2130-655-0A0	D-CHAIN LOOP.TATE-UP GUIDE(1) ASM.	二重環天秤ガイド (1) (組)	(1)
35		A2130-655-000	D-CHAIN LOOP.TATE-UP GUIDE(1)	二重環天秤ガイド (1)	(1)
36		A2131-655-0A0	TAKE-UP GUIDE(2)ASM.	二重環天秤ガイド (2) (組)	(1)
37		SM-0030401-SC	SCREW M3 L=4	二重環天秤ガイド (2) 止めねじ	(1)
38		A2134-9DC-000	LOWER THREAD GUIDE PLATE	下糸案内板	(1)
39		SM-4030455-SN	SCREW	下糸案内板止めねじ	(1)
40		SM-4030455-SN	SCREW	二重環天秤ガイド (1) 止めねじ	(1)
41		SM-4040655-SN	SCREW M4X0.7 L=6	二重環天秤ガイド (総組) 止めねじ	2
42		A2161-9DC-000	NEEDLE GUARD (BACK)	後針受け	1
43		A2160-9DC-000	NEEDLE GUARD (FRONT)	前針受	1
44		SM-9030650-SN	SCREW	前針受止めねじ	1
45		SM-5030655-SN	SCREW M3X0.5 L=6	後針受け止めねじ	2
46		SM-8040402-TP	SCREW M4X0.7 L=4	二重環角駒軸止めねじ	1

7. LOOPER THREAD TENSION COMPONENTS

ルーパー糸調子関係

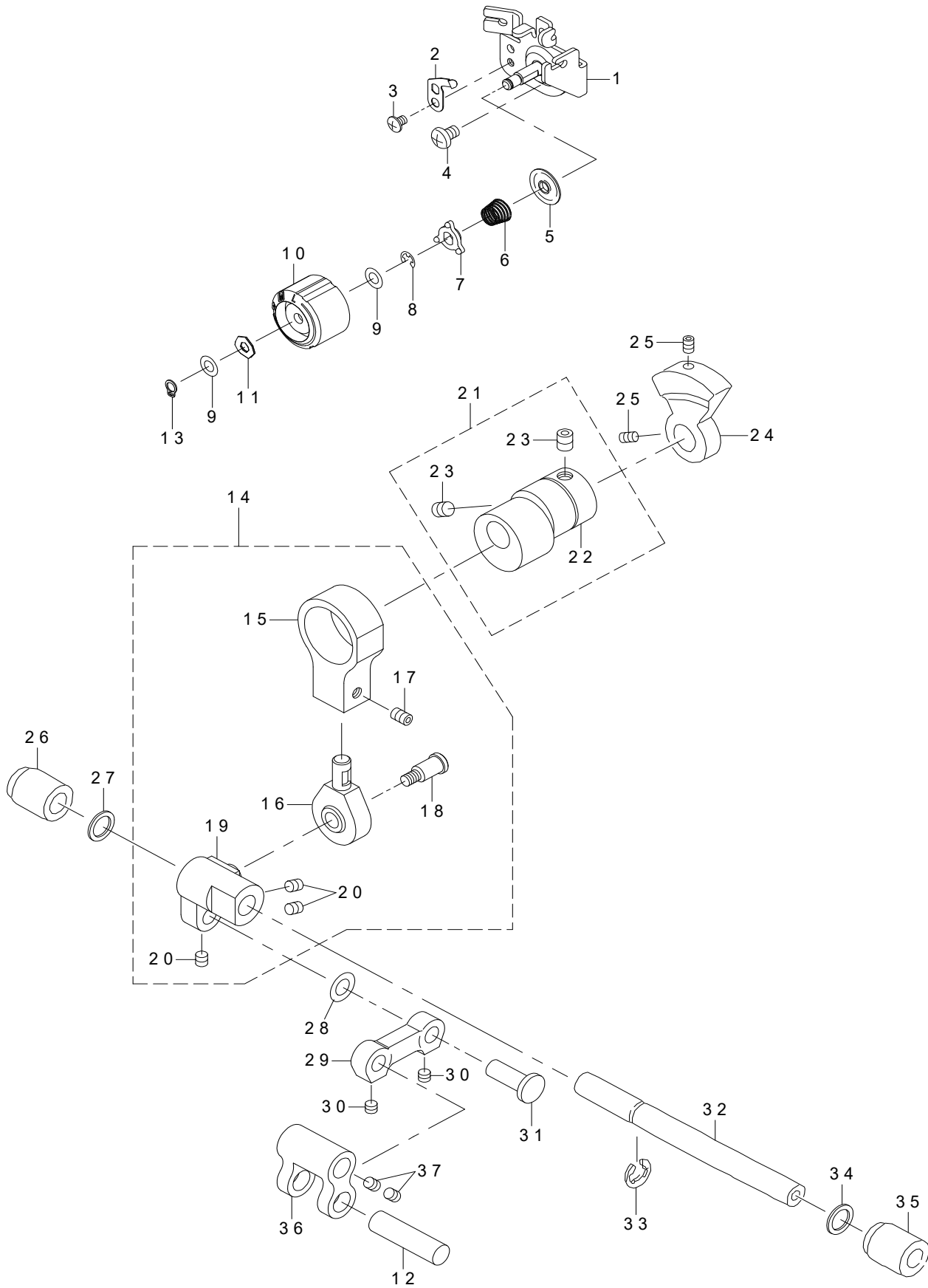

REF.NO	NOTE	PART NO	DESCRIPTION	品名	Qty
1		A2140-9DC-0A0	UNDER THREAD BASE PLATE ASM.	下糸調子取付台(組)	1
2		A2143-9DC-000	U.THR.TENS.DIAL LATCH SPRING	下糸調子ダイヤルラッチばね	1
3		SM-0030401-SC	SCREW M3 L=4	下糸調子ダイヤルラッチばね止めねじ	1
4		SM-4040655-SN	SCREW M4X0.7 L=6	下糸調子取付台(組) 止めねじ	1
5		A2145-9DC-000	LOOPER THREAD TENSION DISC	ルーパー糸糸調子皿	1
6		401-33733	SPRING	糸調子ばね	1
7		A2142-9DC-000	UNDER THR.TENS.SPRING P. PLATE	下糸調子ばね押え板	1
8		RE-0300000-K0	E-RING 3	下糸調子軸止めEリング	1
9		WP-0430801-SC	WASHER M4	波座金	2
10		A2146-9DC-000-B	UNDER THREAD TENSION DIAL	下糸調子ダイヤル	1
11		A1424-777-000	WASHER	波座金	1
12		A2111-335-000	CHAIN LOOPER SLIDE SHAFT	二重環揺動軸	1
13		A3139-776-000	C-RING	下糸調子ダイヤルCリング	1
14		A2515-9DC-0A0	LOWER LOOPER ROD ASM.	下ルーパーロッド(組)	1
15		A2515-534-000-A	LOWER LOOPER ROD	下ルーパーロッド	(1)
16		A2503-776-000	CONNECTING ROD	連結ロッド	(1)
17		SM-8040602-TP	SCREW M4X0.7 L=6	連結ロッド止めねじ	(1)
18		A2504-776-000	CONNECTING SCREW	連結ねじ	(1)
19		A2516-9DC-000	LOOPER DRIVING ARM	ルーパー駆動腕	(1)
20		SM-8040402-TP	SCREW M4X0.7 L=4	ルーパー駆動腕止めねじ	(3)
21		400-79646	LOWER LOOPER CAM ASM.	下ルーパーカム(組)	1
22		A2514-534-00C	40079646	下ルーパーカム	(1)
23		SM-8050612-TP	SCREW M5X6	下ルーパーカム止めねじ	(2)
24		A2550-534-000-C	LOOPER BALANCER	ルーパーバランサー	1
25		SM-8030612-TP	SET SCREW	ルーパーバランサー止めねじ	2
26		A2112-204-000	SUB FEED ADJUSTING METAL	二重環軸メタル	1
27		WP-0820516-SP	WASHER 11.6X8.2X0.6	ルーパー軸平座金	1
28		WP-0641600-SD	WASHER M6	二重環揺動ロッド平座金	1
29		A2101-535-000	CHAIN LOOPER ROCKING ROD	二重環揺動ロッド	1
30		SM-8040402-TP	SCREW M4X0.7 L=4	二重環揺動ロッド止めねじ	2
31		A1403-102-000	CONNECTING PIN	連結ピン	1
32		A2521-9DC-000	LOOPER SHAFT	ルーパー軸	1
33		RE-0600000-K0	E-RING 6	ルーパー軸止めEリング	1
34		WP-0820516-SP	WASHER 11.6X8.2X0.6	ルーパー軸平座金	1
35		A2112-204-000	SUB FEED ADJUSTING METAL	二重環軸メタル	1
36		A2102-9DC-000	DOUBLE-CHAIN OSC.ARM	二重環揺動腕	1
37		SM-8040402-TP	SCREW M4X0.7 L=4	二重環揺動腕止めねじ	2

8. NEEDLE THREAD TENSION COMPONENTS

針糸調子関係

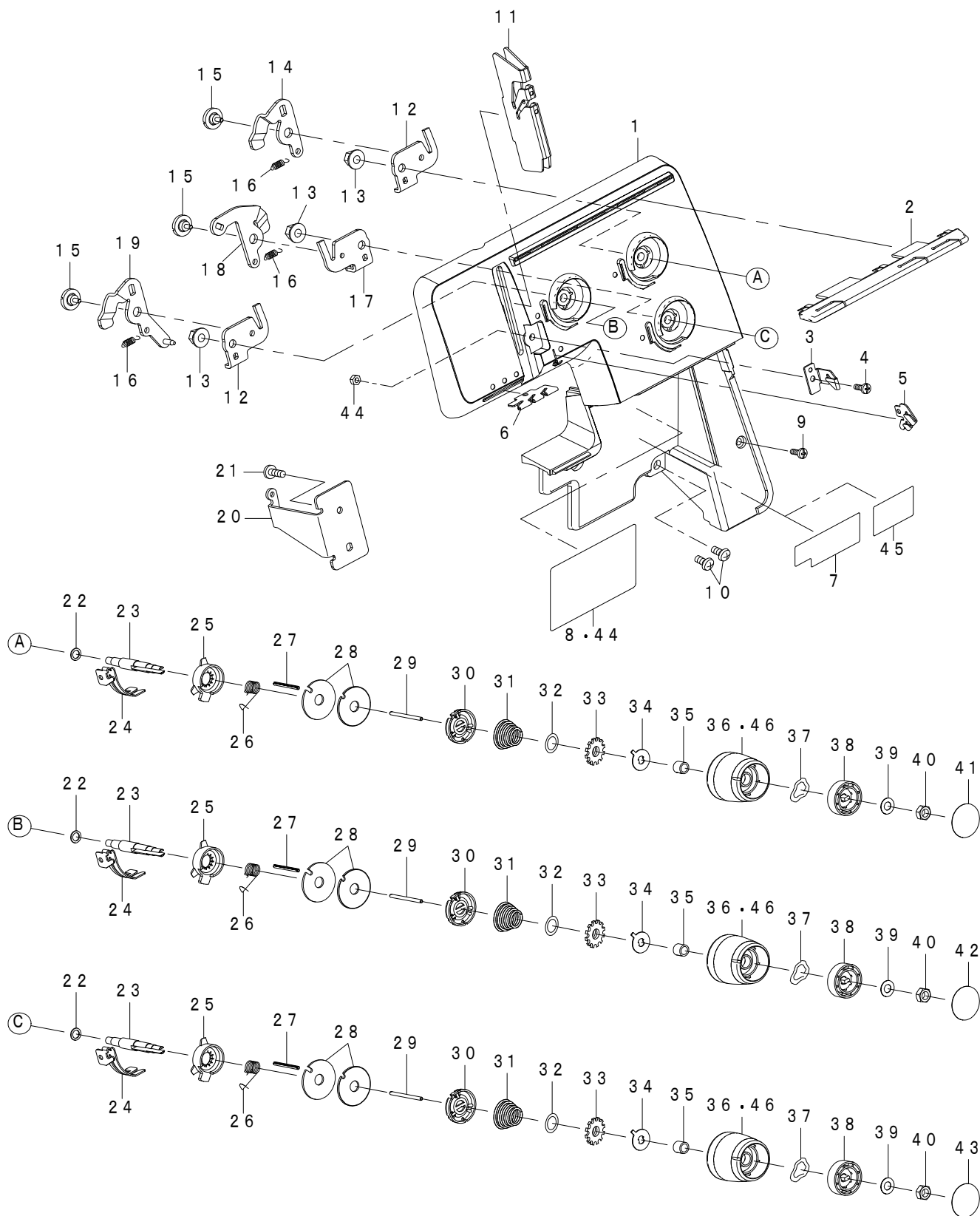

REF.NO	NOTE	PART NO	DESCRIPTION	品名	Qty
1		401-99449	FRONT_COVER_MCS1700	正面カバーMCS1700	1
2		401-22707	ALL_ASSY_1ST_THREAD_GUIDE	第一糸案内(総組)	1
3		401-27197	THREAD_GUIDE_A	糸道糸案内A	1
4		SM-5030855-SN	SCREW	糸道糸案内A止めねじ	1
5		401-27198	THREAD_GUIDE_B	糸道糸案内B	1
6		401-21973	NEEDLE_THREAD_GUIDE	針糸案内	1
7	#01	A9196-524-000	CAUTION_LABEL	注意ラベル	1
8	#01	401-22008	THREADING_CHART	糸通し図	1
9		SM-5030855-SN	SCREW	正面カバー止めねじ	1
10		SM-5040855-SN	SCREW	正面カバー止めねじ	2
11		401-22705	ASSY_NEEDLE_THR_TAKE_UP_GUIDE	針糸天秤ガイド(組)	1
12		A3120-9DC-000	TENS RELEASE CAM FITTING PLATE	皿浮しカム取付板	2
13		A3103-9DC-000	NUT	糸調子軸止めナット	3
14		A3121-9DC-000-A	TENS.RELEASE CAM	皿浮しカム	1
15		A3122-9DC-000	SCREW	皿浮しカム止めねじ	3
16		A3123-9DC-000	SPRING	皿浮しカム押えばね	3
17		401-21980	TENS RELEASE CAM BASE PLATE R	皿浮しカム取付板 右針用	1
18		401-21979	TENS RELEASE CAM R	皿浮しカム 右針用	1
19		401-22709	TENS RELEASE CAM L ASSY	皿浮しカム 左針用(結合)	1
20		A3154-534-D00	FRONT COVER 1ST HOLDER	正面カバー取付板	1
21		ST-5041051-SN	SCREW	正面カバー取付板止めねじ	1
22		WP-0510516-SD	WASHER 5.1X7.5X0.5	糸調子軸平座金	3
23		A3102-9DC-000	THREAD TENSION SHAFT	糸調子軸	3
24		A3121-502-000	THREAD TENSION THRAD GUIDE	糸調子糸案内	3
25		A3120-535-000	THR.HOLDING SPRING BASE PLATE	糸取ばね取付台	3
26		A3103-535-000	THR.HOLDING SPRING	糸取りばね	3
27		PS-0200202-KP	SPRING PIN	糸調子皿回り止めピン	3
28		A3910-634-000-B	TENSION DISC	糸調子皿	6
29		A3124-9DC-000-A	PIN	皿浮しピン	3
30		A3110-9DC-000	THR.TENS.DISC PRESSER	糸調子皿押え	3
31		A3903-634-000	SPRING	糸調子ばね(3)	3
32		A3158-535-000	THREAD ADJUSTING SPRING WASHER	糸調子ばね座金	3
33		A3134-634-000	TENSION NUT	糸調子調節ナット	3
34		A3111-9DC-000	TENS.DIAL POS.PLATE	糸調子ダイヤル位置決め板	3
35		A3105-9DC-000	COLLAR	糸調子ダイヤルカラー	3
36		A3104-9DC-000-B	THR.TENS.ADJ.DIAL	糸調子ダイヤル	3
37		A3106-202-000	WAVED WASHER	糸調子ダイヤル波座金	3
38		A3108-9DC-000	THR.TENS.DIAL PRESSER PLATE	糸調子ダイヤル押え板	3
39		A3109-9DC-000	WASHER	糸調子ダイヤル押え板座金	3
40		NM-6050003-SC	NUT M5X0.8 TYPE3	糸調子ダイヤル止めナット	3
41		401-74068	NEEDLE_THREAD_TENSION_SEAL_M	中針糸調子シール	1
42		401-74066	NEEDLE_THREAD_TENSION_SEAL_L	左針糸調子シール	1
43		401-74070	NEEDLE_THREAD_TENSION_SEAL_R	右針糸調子シール	1
44	#02	401-74171	THREADING_CHART	糸通し図	1
45	#02	400-77574	CAUTION_LABEL	安全注意ラベル	1
46	#03	402-14606	THREAD TENSION ADJUST DIAL	糸調子ダイヤル	3
		NOTE(注記)	#01....FOR FOREIGN	海外用	
			#02....FOR JP	国内用	
			#03....FOR MCS-1800	MCS-1800用	

9. LAMP, MOTOR & CONTROLLER COMPONENTS

ランプ・モーター・コントローラ関係

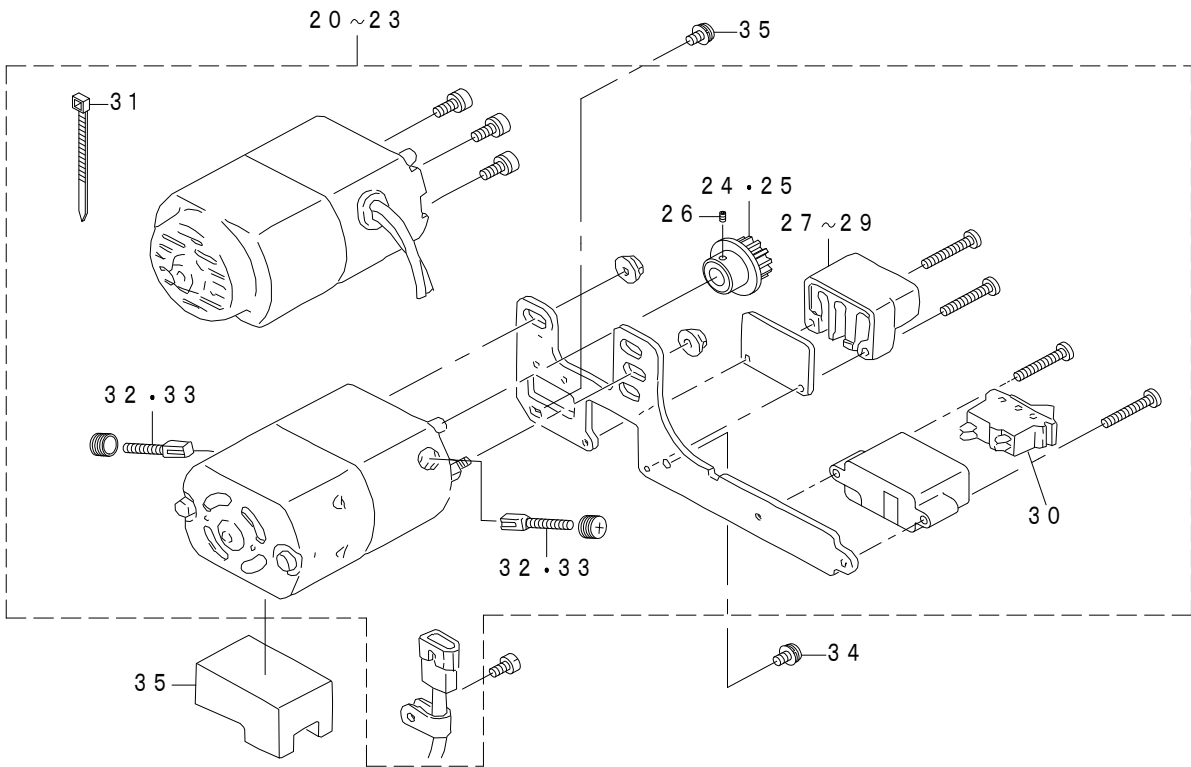
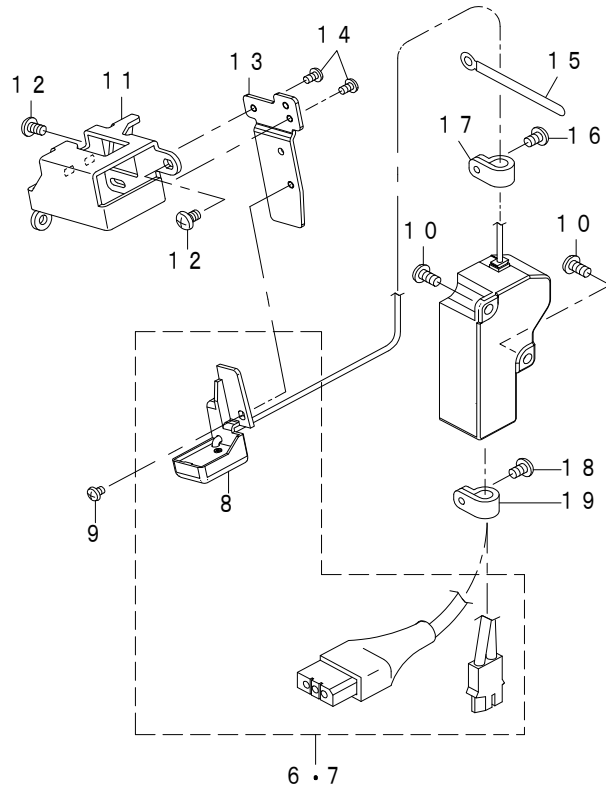
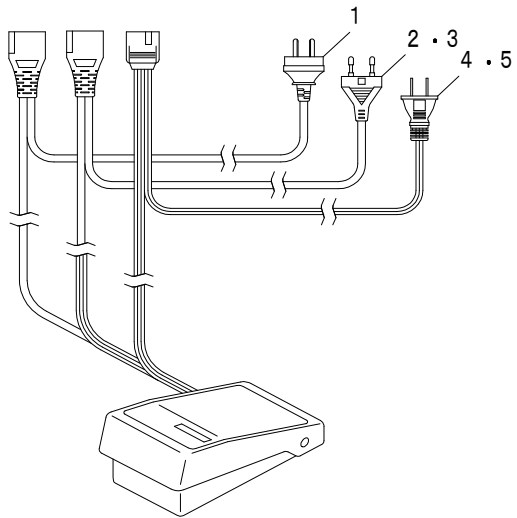

REF.NO	NOTE	PART NO	DESCRIPTION	品名	Qty
1	#03	A6401-110-00B-B	CONTROLLER ASM. SAA	コントローラー (組) SAA	1
2	#02	A6401-110-00A-B	CONTROLLER ASM. CE	コントローラー (組) CE	1
3	#04	A6401-64D-0AE-A	CONTROLLER ASM. CH	コントローラー (組) CH	1
4	#01	A6401-634-DA0-C	CONTROLLER ASM. UL	コントローラー (組) UL	1
5	#05	MSA-1730AHAJ-A	CONTROLLER ASM. JP	コントローラー (組) JP	1
6	#08	402-14601	LED LAMP ASSY UL	LEDランプ (総組) UL	1
7	#06	402-14600	LED LAMP ASSY EU	LEDランプ (総組) EU	1
8		402-10958	LED COVER	LEDランプ	(1)
9		SM-5030455-SN	SCREW M3 L=4	LEDランプカバー止めねじ	1
10		SM-5040855-SN	SCREW	コンバータボックス止めねじ	2
11		A6007-535-000	LAMP HOLDER SUPPORT	ランプ取付台	1
12		SM-4040655-SN	SCREW M4X0.7 L=6	ランプ取付台止めねじ	2
13		402-10959	LAMP COVER HOLDER	ランプカバー取付板	1
14		SM-5030555-SC	SCREW	ランプホルダー止めねじ	2
15		A3811-550-000	CORD HOLDER	コード止め	1
16		SM-4040655-SN	SCREW M4X0.7 L=6	ケーブルクリップ止めねじ	1
17		HX-0015000-0B	CABLE CLAMP	ケーブルクリップ	1
18		SM-4040655-SN	SCREW M4X0.7 L=6	ケーブルクリップ止めねじ	1
19		HX-0015000-0B	CABLE CLAMP	ケーブルクリップ	1
20	#01	A6301-524-0B0-A	MOTOR ASM. UL	モーター (組) UL	1
21	#07	A6301-524-0BB-B	MOTOR ASM. CE	モーター (組) CE	1
22	#04	401-74446	MOTOR ASM. CH	モーター (組) CH	1
23	#05	A6301-C09-0A0	MOTOR ASM. JP	モーター (組) JP	1
24	#08	A6010-634-000-A	MOTOR PULLEY	モータープーリー	(1)
25	#06	A6010-634-00A	MOTOR PULLEY ASM.	絶縁モータープーリー (組)	(1)
26		SM-8040602-TP	SCREW M4X0.7 L=6	モータープーリー止めねじ	(1)
27	#01	A6001-102-U00-A	TERMINAL UL	ターミナル UL	(1)
28	#06	A6001-102-G00	TERMINAL CE	ターミナル CE	(1)
29	#05	A6001-102-J00-A	TERMINAL JP	ターミナル JP	(1)
30		A6003-64D-000	POWER SWITCH	電源スイッチ	(1)
31		A4078-550-00B	BAND	束線バンド	(1)
32	#01	A6090-110-000	CARBON BRUSH	輸出用 (UL) カーボンブラシ (補用)	(2)
33	#04	401-76231	CARBON BRUSH	カーボンブラシ	(2)
34		SL-4040855-SN	SCREW M4 L=8	モーターブラケット止めねじ	2
35		A6003-535-000-A	MOTOR PROTECTOR	モータープロテクター	1
		NOTE(注記)	#01....FOR UL #02....FOR CE/IT #03....FOR SAA #04....FOR CH #05....FOR JP #06....FOR CE/BS/SAA/IT/CH #07....FOR CE/BS/SAA/IT #08....FOR UL/JP	UL 用 CE / IT 用 SAA 用 CH 用 JP 用 CE / BS / SAA / IT / CH 用 CE / BS / SAA / IT 用 UL / JP 用	

10. ACCESSORIES PARTS & OPTION COMPONENTS

付属品・オプション関係

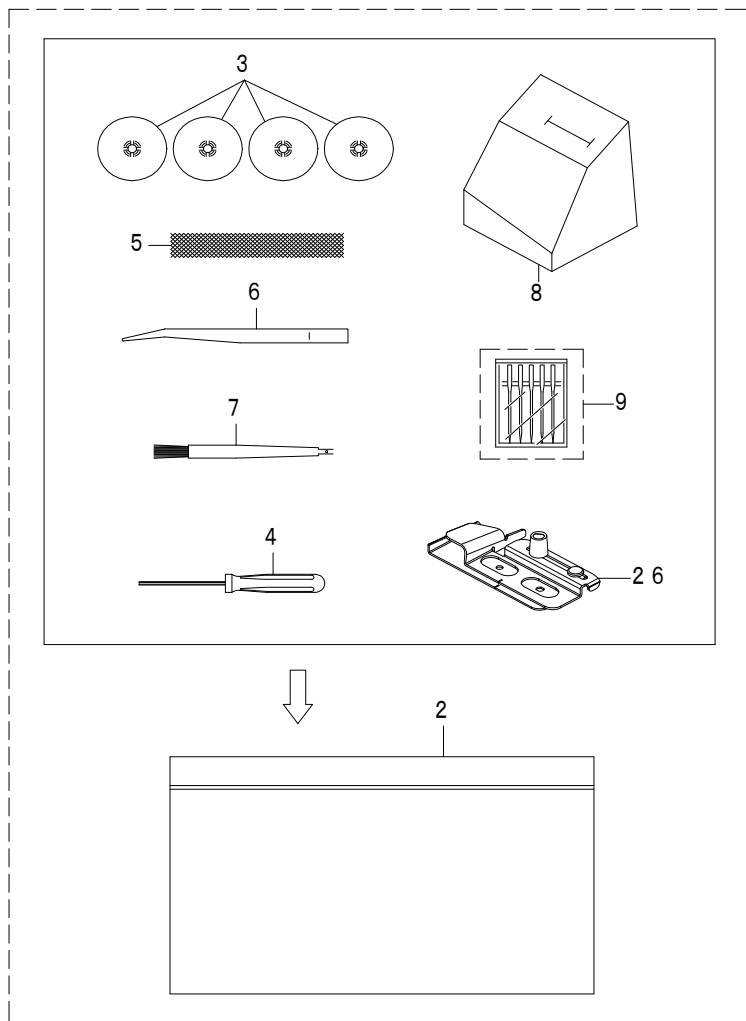

1・25

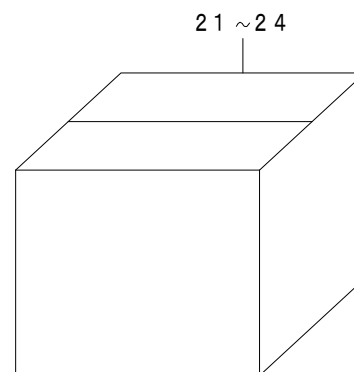
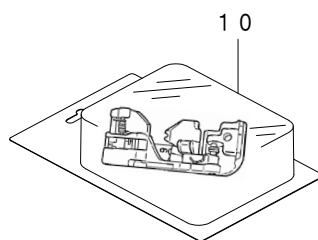
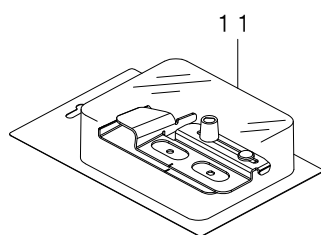
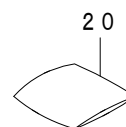
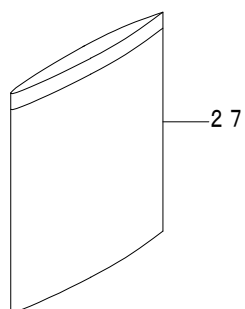
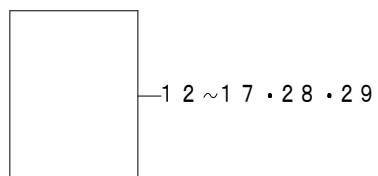
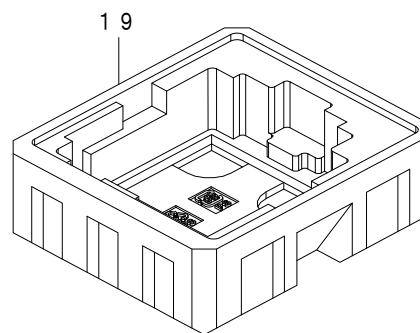
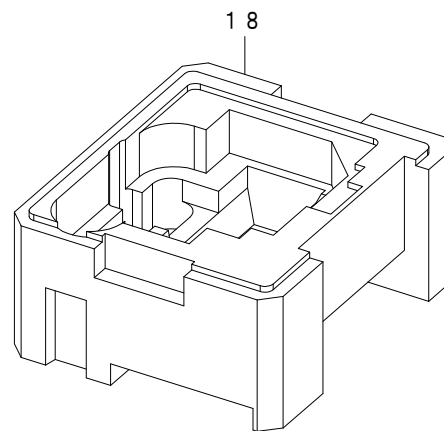

REF.NO	NOTE	PART NO	DESCRIPTION	品名	Qty
1		401-74075	ASSY_ACCESSORY_BAG	付属品バック(組)	1
2		B9101-552-000	ACCESSORY BAG	付属品バック	(1)
3		A1150-980-00A	SPOOL CAP	糸巻き当て座(大)	(4)
4		401-22044	HEXAGONAL DRIVER	六角ドライバー(小)	(1)
5		A9116-335-000	PLASTIC NET	糸巻きネット	(1)
6		A9109-202-000	TWEEZERS	ピンセット	(1)
7		400-65952	NEEDLE_INSERTER_TOOL/BRUSH	掃除用ブラシ	(1)
8		A9102-800-000	VINYL COVER	頭部ビニールカバー	(1)
9		401-67415	NEEDLE_ASM	針(組)	(1)
10		401-77370	ASSY_BP_DOUBLE_CHAIN_P_FOOT	二重環押えBP(組)	1
11		401-77371	ASSY_BP_HEMMER_GUIDE_FOR_CS	裾引きガイドBP(組)	1
12	#01	402-14159	INSTRUCSION MANUAL MCS1500N ESF	取扱説明書MCS1500N(英西仏)	1
13	#02	402-14157	INSTRUCSION MANUAL MCS1500N ENG	取扱説明書MCS1500N(英)	1
14	#03	402-16135	INSTRUCSION MANUAL MCS1500N ITA	取扱説明書MCS1500N(伊)	1
15	#04	402-14149	INSTRUCSION MANUAL MCS1500N JP	取扱説明書MCS1500N(日)	1
16	#05	402-14158	INSTRUCSION MANUAL MCS1500N CH	取扱説明書MCS1500N(中)	1
17	#08	402-16136	INSTRUCSION MANUAL MCS1700N_ESF	取扱説明書MCS1700N(英西仏)	1
18		401-21970	STYROFORM TOP	上発砲	1
19		401-22711	STYROFORM BOTTOM	下発砲	1
20		J0240-082-A00	SILICAGEL	シリカゲル	1
21	#06	402-14145	CARTON_CASE_MCS1500N_F	カートンケース MCS1500N海外	1
22	#04	402-14137	CARTON_CASE_MCS1500N_D	カートンケース MCS1500N国内	1
23	#08	402-16128	COLOR_CARTON_CASE_MCS1700N QVP	カラーカートンケースMCS1700N QVP	1
24	#09	402-14141	COLOR_CARTON_MCS1800	カラーカートンケースMCS1800	1
25	#07	402-06832	ASSY_ACCESSORY_BAG	付属品バック(組)	1
26	#07	402-06816	ASSY_HEMMER_GUIDE_FOR_CS	裾引きガイド(組)	(1)
27		A9181-008-000	VINYL	取扱説明書収納袋	1
28	#09	402-14152	INSTRUCSION MANUAL MCS1800 EN	取扱説明書MCS1800(英)	1
29	#09	402-14153	INSTRUCSION MANUAL MCS1800 ITA	取扱説明書MCS1800(伊)	1
		NOTE(注記)	#01....FOR UL	UL用	
			#02....FOR CE/SAA	CE/SAA用	
			#03....FOR IT	IT用	
			#04....FOR JP	JP用	
			#05....FOR CH	CH用	
			#06....FOR FOREIGN	海外用	
			#07....FOR MCS-1700N QVP,MCS-1800	MCS-1700N QVP, MCS-1800用	
			#08....FOR MCS-1700N QVP	MCS-1700N QVP用	
			#09....FOR MCS-1800	MCS-1800用	

NUMERICAL INDEX OF PARTS

索引

PART NO 品番	PAGE 頁	REF NO	PART NO 品番	PAGE 頁	REF NO	PART NO 品番	PAGE 頁	REF NO	PART NO 品番	PAGE 頁	REF NO
A1102-523-0A0-A	2	54	A1619-655-0A0	10	23	A2504-776-000	14	18	PS-0200202-KP	16	27
A1103-C09-000	2	19	A1620-534-DA0	10	11	A2514-534-00C	14	22	PS-0400222-KP	4	2
A1104-523-000-A	2	31	A1625-800-000	10	63	A2515-534-000-A	14	15			
A1118-644-000-A	2	5	A1627-C09-000	10	64	A2515-9DC-0A0	14	14	RE-0200000-K0	12	33
A1119-644-000-A	2	7	A1630-534-D00	10	20	A2516-9DC-000	14	19	RE-0300000-K0	8	4
A1120-202-000	2	4	A1630-535-000	10	96	A2521-9DC-000	14	32	RE-0300000-K0	8	8
A1121-202-000	2	3	A1633-534-D00	10	28	A2529-335-000	10	85	RE-0300000-K0	10	14
A1121-315-0A0-A	2	8	A1634-655-000-A	10	24	A2529-335-000	12	4	RE-0300000-K0	10	22
A1135-535-000	2	42	A1635-534-D00	10	30	A2538-554-000	2	49	RE-0300000-K0	10	45
A1138-110-000	2	24	A1637-534-DA0	10	97	A2550-534-000-C	14	24	RE-0300000-K0	10	80
A1138-335-000	2	11	A1638-776-000	10	91	A3102-9DC-000	16	23	RE-0300000-K0	10	83
A1139-9DC-000-B	2	22	A1639-534-D00	10	88	A3103-535-000	16	26	RE-0300000-K0	14	8
A1145-523-000	2	13	A1639-800-000	10	69	A3103-9DC-000	16	13	RE-0400000-K0	6	53
A1146-644-000	2	16	A1640-534-D00	10	86	A3104-9DC-000-B	16	36	RE-0400000-K0	10	8
A1147-535-000	2	17	A1641-534-D00	10	60	A3105-9DC-000	16	35	RE-0400000-K0	10	18
A1150-980-00A	20	3	A1642-C09-000	10	74	A3106-202-000	16	37	RE-0400000-K0	10	59
A1153-503-0AC	2	56	A1645-534-D00	10	55	A3108-9DC-000	16	38	RE-0400000-K0	10	89
A1156-523-000	2	51	A1646-534-D00	10	56	A3109-9DC-000	16	39	RE-0400000-K0	12	10
A1160-524-000	2	32	A1647-534-D00	10	61	A3110-9DC-000	16	30	RE-0500000-K0	6	51
A1161-535-0A0	2	36	A1648-655-000	10	73	A3111-9DC-000	16	34	RE-0500000-K0	10	27
A1164-535-000	2	47	A1650-534-D00	10	84	A3120-031-000	2	23	RE-0500000-K0	10	29
A1167-315-00A-A	12	26	A1651-534-D00	10	77	A3120-535-000	16	25	RE-0500000-K0	10	39
A1202-113-000	4	6	A1652-534-D00	10	81	A3120-9DC-000	16	12	RE-0500000-K0	10	46
A1205-634-000	4	9	A1653-776-000	10	42	A3121-502-000	16	24	RE-0500000-K0	10	57
A1206-102-000	4	5	A1654-776-000-A	10	47	A3121-9DC-000-A	16	14	RE-0500000-K0	10	68
A1206-202-000	4	4	A1655-534-D00	10	13	A3122-9DC-000	16	15	RE-0600000-K0	6	8
A1206-335-000	4	3	A1657-534-DA0	10	43	A3123-9DC-000	16	16	RE-0600000-K0	14	33
A1206-535-000	4	7	A1659-534-D00-A	10	41	A3124-9DC-000-A	16	29			
A1230-500-000-A	4	8	A1660-534-D00-A	10	33	A3134-634-000	16	33	SL-4040831-SF	2	20
A1401-535-000-A	6	20	A1660-534-D00-A	10	48	A3139-776-000	14	13	SL-4040855-SN	2	38
A1402-535-000	6	5	A1661-800-0A0	10	38	A3150-535-000	2	39	SL-4040855-SN	2	50
A1403-102-000	6	2	A1662-655-000-A	10	16	A3151-535-000	2	21	SL-4040855-SN	18	34
A1403-102-000	6	22	A1663-534-D00	10	50	A3154-534-D00	16	20	SL-5031031-SN	2	15
A1403-102-000	14	31	A1663-776-0A0	10	35	A3158-535-000	16	32	SM-0030401-SC	12	37
A1403-335-000-A	6	19	A1663-776-000	10	36	A3811-550-000	18	15	SM-0030401-SC	14	3
A1404-535-000	6	14	A1664-655-000	10	34	A3903-634-000	16	31	SM-1030801-SN	6	26
A1407-102-000	6	10	A1665-534-D00	10	79	A3910-634-000-B	16	28	SM-4030455-SN	6	32
A1407-102-000	6	13	A1675-335-000	12	12	A4078-550-00B	18	31	SM-4030455-SN	12	39
A1411-335-000	6	9	A2101-535-000	14	29	A4125-655-000	2	46	SM-4030455-SN	12	40
A1412-130-000	6	3	A2102-9DC-000	14	36	A6001-102-G00	18	28	SM-4030655-SP	10	65
A1412-535-000	6	1	A2103-9DC-000	12	2	A6001-102-J00-A	18	29	SM-4030655-SP	10	67
A1414-502-0A0	6	16	A2105-535-000	12	1	A6001-102-U00-A	18	27	SM-4030655-SP	10	71
A1414-502-000	6	17	A2107-655-000	12	13	A6003-535-000-A	18	35	SM-4030655-SP	10	75
A1415-523-000	6	11	A2109-9DC-000	12	17	A6003-64D-000	18	30	SM-4040655-SN	10	54
A1424-777-000	14	11	A2111-335-000	14	12	A6007-535-000	18	11	SM-4040655-SN	12	41
A1502-C09-000	6	36	A2112-204-000	14	26	A6010-634-00A	18	25	SM-4040655-SN	14	4
A1504-9DC-0B0	6	48	A2112-204-000	14	35	A6010-634-000-A	18	24	SM-4040655-SN	18	12
A1507-C09-000	6	40	A2113-535-000-A	12	8	A6090-110-000	18	32	SM-4040655-SN	18	16
A1514-C09-0B0-B	6	42	A2114-535-000	12	5	A6301-C09-0A0	18	23	SM-4040655-SN	18	18
A1520-130-000	6	43	A2115-655-000	12	11	A6301-524-0BB-B	18	21	SM-4040855-SN	2	52
A1521-110-00C	6	44	A2116-535-000	12	7	A6301-524-0B0-A	18	20	SM-4040855-SN	6	49
A1522-110-000	6	38	A2130-655-0A0	12	34	A6401-110-00A-B	18	2	SM-5030455-SF	10	101
A1523-110-000	6	39	A2130-655-000	12	35	A6401-110-00B-B	18	1	SM-5030455-SN	18	9
A1572-9DC-000	6	52	A2130-9DC-0B0	12	31	A6401-634-DA0-C	18	4	SM-5030555-SC	6	4
A1573-9DC-0A0	8	7	A2131-655-0A0	12	36	A6401-64D-0AE-A	18	3	SM-5030555-SC	12	24
A1577-9DC-000	8	2	A2132-655-0A0	12	32	A9102-800-000	20	8	SM-5030555-SC	18	14
A1578-9DC-000	8	1	A2134-9DC-000	12	38	A9109-202-000	20	6	SM-5030655-SF	8	5
A1601-556-D00-B	10	2	A2138-335-000	12	30	A9116-335-000	20	5	SM-5030655-SF	8	11
A1602-534-D00-B	10	3	A2140-9DC-0A0	14	1	A9181-008-000	20	27	SM-5030655-SN	10	15
A1603-65D-E00	10	4	A2142-9DC-000	14	7	A9196-524-000	2	44	SM-5030655-SN	10	21
A1604-534-D00-A	10	5	A2143-9DC-000	14	2	A9196-524-000	16	7	SM-5030655-SN	10	44
A1610-9DC-000	10	1	A2145-9DC-000	14	5				SM-5030655-SN	12	18
A1611-655-000	10	6	A2146-9DC-000-B	14	10	B9101-552-000	20	2	SM-5030655-SN	12	45
A1612-535-000	10	98	A2151-9DC-000-A	12	15				SM-5030855-SN	6	47
A1613-535-000	10	53	A2152-9DC-000	12	21	HX-0015000-0B	18	17	SM-5030855-SN	10	10
A1613-655-000	10	17	A2153-655-0A0	12	25	HX-0015000-0B	18	19	SM-5030855-SN	10	19
A1614-534-D00	10	12	A2154-9DC-000	2	34				SM-5030855-SN	10	40
A1614-655-000	10	32	A2155-655-000-A	12	20	J0240-082-A00	20	20	SM-5030855-SN	16	4
A1615-534-D00	10	9	A2156-655-000	12	28				SM-5030855-SN	16	9
A1616-030-Z00	10	66	A2158-655-000	12	19	MC-2215008-00	6	54	SM-5031001-SE	10	49
A1616-030-Z00	10	70	A2159-655-000	12	27	MSA-1730AHAJ-A	18	5	SM-5031001-SE	10	52
A1616-534-D00	10	90	A2160-9DC-000	12	43				SM-5032555-SE	2	41
A1617-534-D00-A	10	94	A2161-9DC-000	12	42	NM-6050003-SC	16	40	SM-5040655-SN	10	7
A1618-534-D0A	10	93	A2165-9DC-000	12	23				SM-5040855-SN	2	43
A1618-534-D00	10	92	A2503-776-000	14	16	PS-0200052-KP	8	10	SM-5040855-SN	2	48

NUMERICAL INDEX OF PARTS

索引

PART NO 品番	PAGE 頁	REF NO	PART NO 品番	PAGE 頁	REF NO	PART NO 品番	PAGE 頁	REF NO	PART NO 品番	PAGE 頁	REF NO
SM-5040855-SN	2	59	401-21980	16	17						
SM-5040855-SN	6	41	401-21981	8	6						
SM-5040855-SN	16	10	401-21983	8	9						
SM-5040855-SN	18	10	401-21986	2	62						
SM-5041055-SN	10	26	401-21988	2	28						
SM-5041055-SN	10	31	401-21997	6	23						
SM-5043755-SC	2	6	401-21998	6	24						
SM-5051255-SN	2	9	401-21999	6	25						
SM-5051255-SN	2	55	401-22000	2	10						
SM-8030302-TP	10	37	401-22001	6	33						
SM-8030302-TP	10	72	401-22008	16	8						
SM-8030302-TP	12	16	401-22010	2	45						
SM-8030402-TP	10	78	401-22044	20	4						
SM-8030402-TP	10	87	401-22701	2	2						
SM-8030612-TP	14	25	401-22704	12	14						
SM-8040402-SP	6	18	401-22705	16	11						
SM-8040402-TP	2	53	401-22707	16	2						
SM-8040402-TP	6	6	401-22709	16	19						
SM-8040402-TP	6	15	401-22711	20	19						
SM-8040402-TP	10	51	401-23323	6	29						
SM-8040402-TP	10	58	401-23324	6	28						
SM-8040402-TP	10	62	401-25265	6	27						
SM-8040402-TP	10	99	401-25609	6	35						
SM-8040402-TP	12	6	401-27196	6	31						
SM-8040402-TP	12	9	401-27197	16	3						
SM-8040402-TP	12	46	401-27198	16	5						
SM-8040402-TP	14	20	401-27201	6	50						
SM-8040402-TP	14	30	401-33733	14	6						
SM-8040402-TP	14	37	401-39206	6	34						
SM-8040412-TP	12	3	401-67415	20	9						
SM-8040602-TP	12	22	401-72181	10	100						
SM-8040602-TP	14	17	401-74061	2	12						
SM-8040602-TP	18	26	401-74063	2	27						
SM-8040612-TP	10	95	401-74066	16	42						
SM-8050402-TP	6	37	401-74068	16	41						
SM-8050602-TP	6	21	401-74070	16	43						
SM-8050612-TP	14	23	401-74075	20	1						
SM-8050842-TP	2	40	401-74171	16	44						
SM-8060602-TP	6	12	401-74446	18	22						
SM-9030650-SN	12	44	401-76231	18	33						
SM-9040700-SP	10	76	401-77370	20	10						
ST-5030851-SN	2	18	401-77371	20	11						
ST-5030851-SN	2	26	401-82063	2	14						
ST-5031051-SN	2	33	401-97624	2	60						
ST-5031051-SN	2	35	401-97629	4	10						
ST-5041051-SN	2	30	401-99449	16	1						
ST-5041051-SN	2	37	402-06816	20	26						
ST-5041051-SN	2	58	402-06832	20	25						
ST-5041051-SN	16	21	402-10958	18	8						
			402-10959	18	13						
WP-0320501-SC	2	25	402-14126	2	61						
WP-0320501-SC	6	46	402-14133	2	63						
WP-0430801-SC	2	29	402-14137	20	22						
WP-0430801-SC	2	57	402-14141	20	24						
WP-0430801-SC	8	3	402-14145	20	21						
WP-0430801-SC	10	25	402-14149	20	15						
WP-0430801-SC	10	82	402-14152	20	28						
WP-0430801-SC	14	9	402-14153	20	29						
WP-0510516-SD	16	22	402-14157	20	13						
WP-0531001-SC	6	45	402-14158	20	16						
WP-0641600-SD	14	28	402-14159	20	12						
WP-0820516-SP	6	7	402-14600	18	7						
WP-0820516-SP	14	27	402-14601	18	6						
WP-0820516-SP	14	34	402-14606	16	46						
			402-16128	20	23						
400-65952	20	7	402-16135	20	14						
400-71774	4	1	402-16136	20	17						
400-77574	16	45									
400-79646	14	21									
400-82787	2	1									
401-21970	20	18									
401-21972	6	30									
401-21973	16	6									
401-21975	12	29									
401-21979	16	18									

JUKI[®]

JUKI CORPORATION

2-11-1, TSURUMAKI, TAMA-SHI,
TOKYO, 206-8551, JAPAN
PHONE:(81)42-357-2341

Copyright© 2018 JUKI CORPORATION
本書の内容を無断で転載、複写することを
禁止します。
All rights reserved throughout the world.

JUKI 株式会社

〒 206-8551 東京都多摩市鶴牧 2-11-1 TEL.042-357-2341(ダイヤルイン)

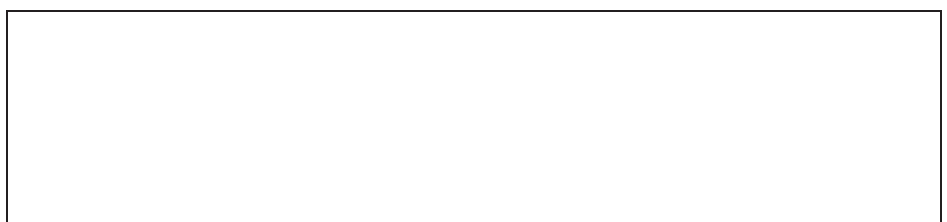

※このパーツリストは商品改良のため予告なく変更する事があります。
*The description covered in this parts list is subject to change for improvement of the commodity without notice.
※このパーツリストは 2018年 10 月現在の商品仕様で編集したものです。
*This parts list is edited in accordance with the product specifications as of October 2018.