

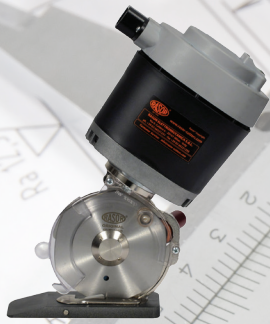

100% MADE IN ITALY



AVAILABLE IN  
RIGHT VERSION  
SW100S



1946

# SW100SL ELECTRIC CUTTING UNIT

SW100SL. Professional cutting unit for Textile & Technical Textile applications.



1946

# ELECTRIC CUTTING UNIT SW100SL

## WHAT'S NEW:

- New sharpening device system
- Easy fixing structure for O.E.M applications
- Low-friction Teflon® coated foot

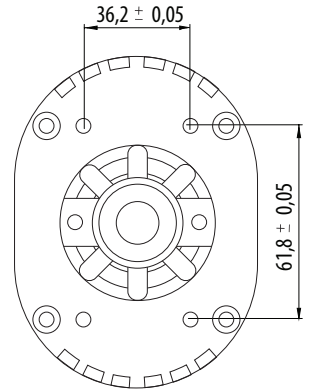

Fixing layout

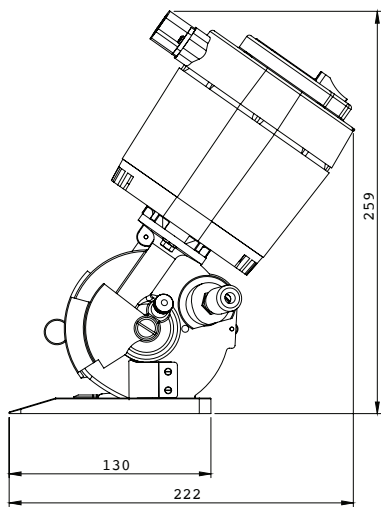

Dimension layout

## TECHNICAL DETAILS:

- Blade diameter:** 100 mm (4"), with hard metal counterblade
- Blade equipped:** 10EHSS, 6-edges, HSS steel
- Blade speed:** 850 r.p.m.
- Cutting ability:** up to 35 mm (1.4")
- Power:** single phase – 90 W
- Max. absorption:** 2 A
- Net weight:** 2650 g (with power supply cord)
- Total weight (with packing box):** 4750 g
- Electric cable length:** 1.5 mt (with no plug)
- Minimum brightness for working operations:** LUX 200
- Vibrations at start up:** < 2.5 m/sec<sup>2</sup>
- Temperature range:** 0 – 55 C
- Umidity range:** 10 – 95% without condensate

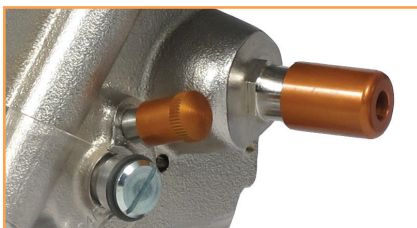

## BLADE AVAILABLE:

**10EHSS**, 100 mm 6-edges, HSS steel | **10SEXTG**, 100 mm 4-edges, EXTRA steel | **10CSW**, 100 mm circular, HSS steel | **10EHSSTF**, 100 mm 6-edges, HSS steel Teflon® coated | **10EMD**, 100 mm 6-edges, Carbide (Widia®)



## FOLLOW US:



## RASOR ELETTROMECCANICA SRL

Via Vincenzo Caldesi 6  
20161 Milan · Italy  
ph. +39 02 66 22 12 31  
fax +39 02 66 22 12 93  
info@rasor-cutters.com

www.rasor-cutters.com