



100% MADE IN ITALY

2017
SERIES



3-PHASES
AVAILABLE IN 480 V
AVAILABLE IN 60 Hz



1946

GRT-MINI ELECTRIC 3-PHASES CUTTING UNIT

GRT-MINI. The smallest professional 3-phases cutting unit for continuous cutting processes.



ELECTRIC 3-PHASES CUTTING UNIT GRT-MINI

WHAT'S NEW:

- New aluminium Teflon® coated base
- New sharpening device system
- Maintenance-free industrial motor
- Easy fixing structure for O.E.M applications

AVAILABLE IN 480 V
AVAILABLE IN 60 Hz



Dimension layout

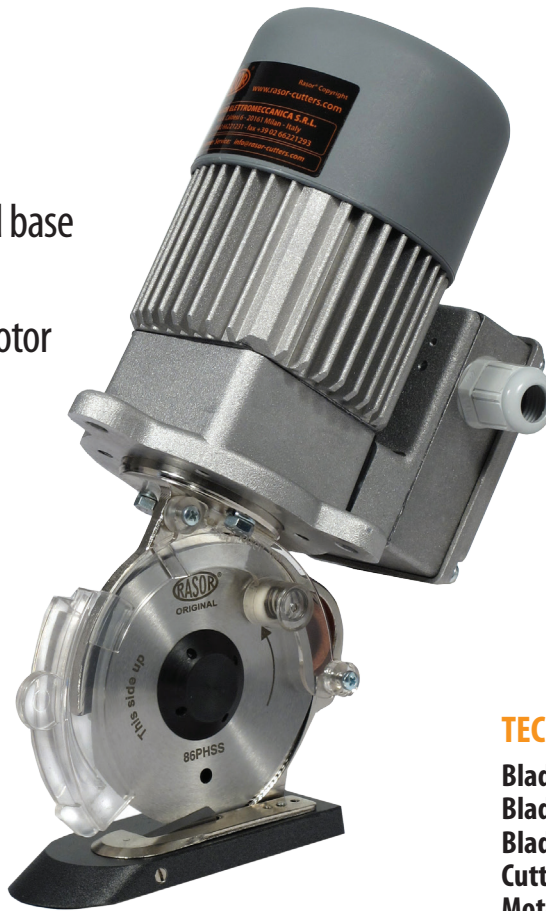
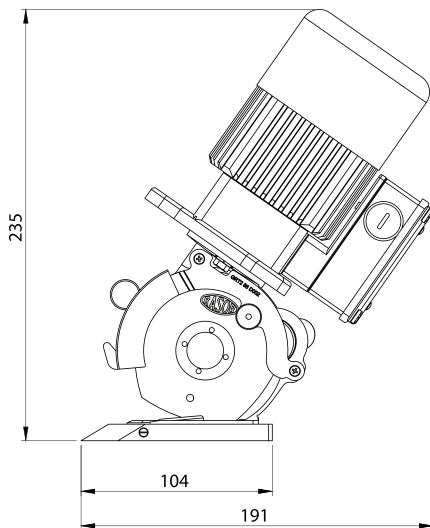

New sharpening device system

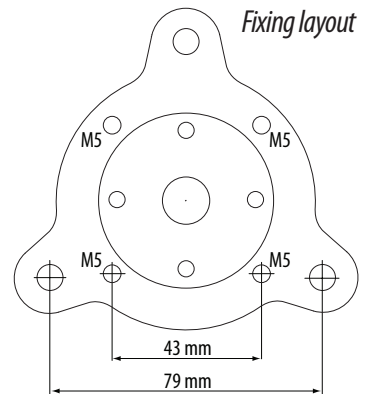
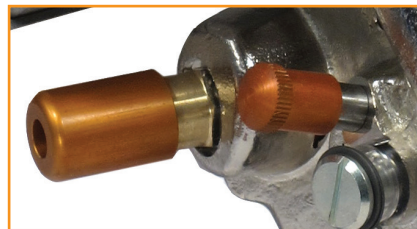

TECHNICAL DETAILS:

- Blade diameter:** 86 mm (3.4")
- Blade equipped:** 86PHSS, 5-edges, HSS steel
- Blade speed:** 550 r.p.m.
- Cutting ability:** up to 25 mm (1")
- Motor:** 3phases asynchronous 380/400 V, 50 Hz
- Power:** 50 W
- Max. absorption:** 0.3 A
- Protection:** IP20 - CL F
- Net weight:** 2650 g (with power supply cord)
- Total weight (with packing box):** 4750 g
- Electric cable length:** 1.5 mt (with no plug)
- Minimum brightness for working operations:** LUX 200
- Vibrations at start up:** < 2.5 m/sec²
- Temperature range:** 0 – 55 C
- Umidity range:** 10 – 95% without condensate

BLADES AVAILABLE:

86PHSS, 86 mm 5-edges, HSS steel | **86THSS**, 86 mm 8-edges, HSS steel | **86PHSSTF**, 86 mm 5-edges, HSS steel Teflon® coated | **86THSSTF**, 86 mm 8-edges, HSS steel Teflon® coated | **86THSSTN**, 86 mm 8-edges, HSS steel Titanium coated | **86TMD**, 86 mm 8-edges, Carbide (Widia®)



FOLLOW US:



RASOR ELETTROMECCANICA SRL

Via Vincenzo Caldesi 6
20161 Milan · Italy
ph. +39 02 66 22 12 31
fax +39 02 66 22 12 93
info@rasor-cutters.com

www.rasor-cutters.com