

JUKI®

SEWING MACHINE

HZL-350Z series

SERVICE MANUAL

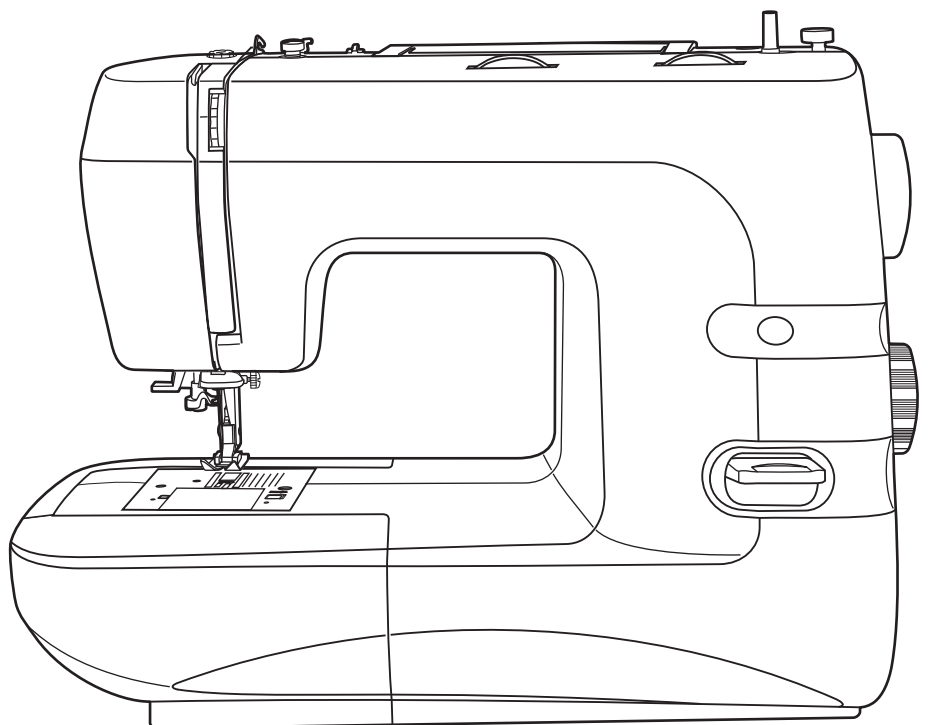

CONTENTS

1. Products specification	2
2. Out look	3
3. Names of principal parts	4
4. Removing methods of external parts	
4.1 Sewing table	5
4.2 Face plate	5
4.3 Cord reel cover	5
4.4 Belt cover	5
4.5 Free arm foot bush	6
4.6 Free arm cover	6
4.7 Front cover	6-7
4.8 Back cover	8
5. Adjusting methods of each part	
5.1 Symbol instructions	9
5.2 Play of arm shaft	10
5.3 Drop middle point of needle	10
5.4 Height of presser foot	11
5.5 Needle flow at maximum zigzag width	12
5.6 Drop middle point of needle	13
5.7 Needle position of zigzag	14
5.8 Automatic needle threader adjustment	15
5.9 Adjustment of feed rock shaft and feed lifting rock cam	16
5.10 Height of needle bar	17
5.11 Timing of needle and hook	18
5.12 Distance-needle-hook	19
5.13 Play between shuttle driver shaft gear and lower shaft gear	20
5.14 Play of shuttle driver shaft	21
5.15 Feed-dog height	22
5.16 Position of feed-dog in relation to the needle plate (left to right)	23
5.17 Upper thread tension adjustment	24
5.18 Shuttle hook tension adjustment	25
5.19 Motor belt tension	26
5.20 Drop point of needle	27
5.21 Forward and reverse stitching in buttonhole sewing (Feeding pitch of reverse and forward stitching is not even)	28
5.22 Bar tack density (stitch advances in upper or lower bar tacking)	29
5.23 Buttonhole length adjustment	30
5.24 Bobbin winding problem	31
6. Circuit diagram	32-33



ATTENTION

Be sure to observe the following, as they may well become causes for fire, electric-shock, injuries, and damage to parts.

- Be sure to unplug power source before engaged in disassembly, installation, adjustment.
- In case of installing please pay special care to clamp electrical cords, etc., scars to sheath, mis-circuit, etc.
- Be sure to use regular standard part in replacing.

1. Products specification

ITEM	TYPE	353Z	355Z	357Z
Machine style		Free arm		
Size of machine (L x W x H)		177 x 410 x 308 mm		
Weight (kg)		7.1 (Only machine)		
Max rotation speed (rpm)		750 ± 50		
Motor power		70W		
Motor type		Series wound / AC		
Rotation control method		Electric type		
Needle position		Center and left position		
Zigzag out-breaking device		Multiple-player cams conversion type		
Hook system		Horizontal hook		
Thread take up lever		Slit type		
Presser foot lift		Two-steps type		
Needle threader		Auto type		
Needle plate		Screw fixing type		
Upper thread tension adjust device		Top of upper plate inclusive turning knob		
Bobbin winder		Self releasing with automatic stop		
Reverse		Press down type		
Press-bar pressure regulating device		Yes		
Kinds of stitches		21	26	32
BH micro adjust device		Yes		
Dials		3		
Zigzag conversion device		Dial type		
Stitch length adjust device		Dial type		
Button hole system		1-step		
Pattern indicating device		Indicated in a transparent window pattern to be selected		
Max. length of stitch (mm)		4.5		
Max. width of zigzag (mm)		7		
Face plate upper plate		Plastic		
Sewing table		Coupled with accessories / spare parts box		
LED lamp		Inclusive within face plate		
Speed control device		Controller		
Power supply switch		Pulsating, two steps		
Hard case		Yes		
Nos. of accessories		Option		
Lower thread remainder indicator		Needle plate, cover type		

2. Out look

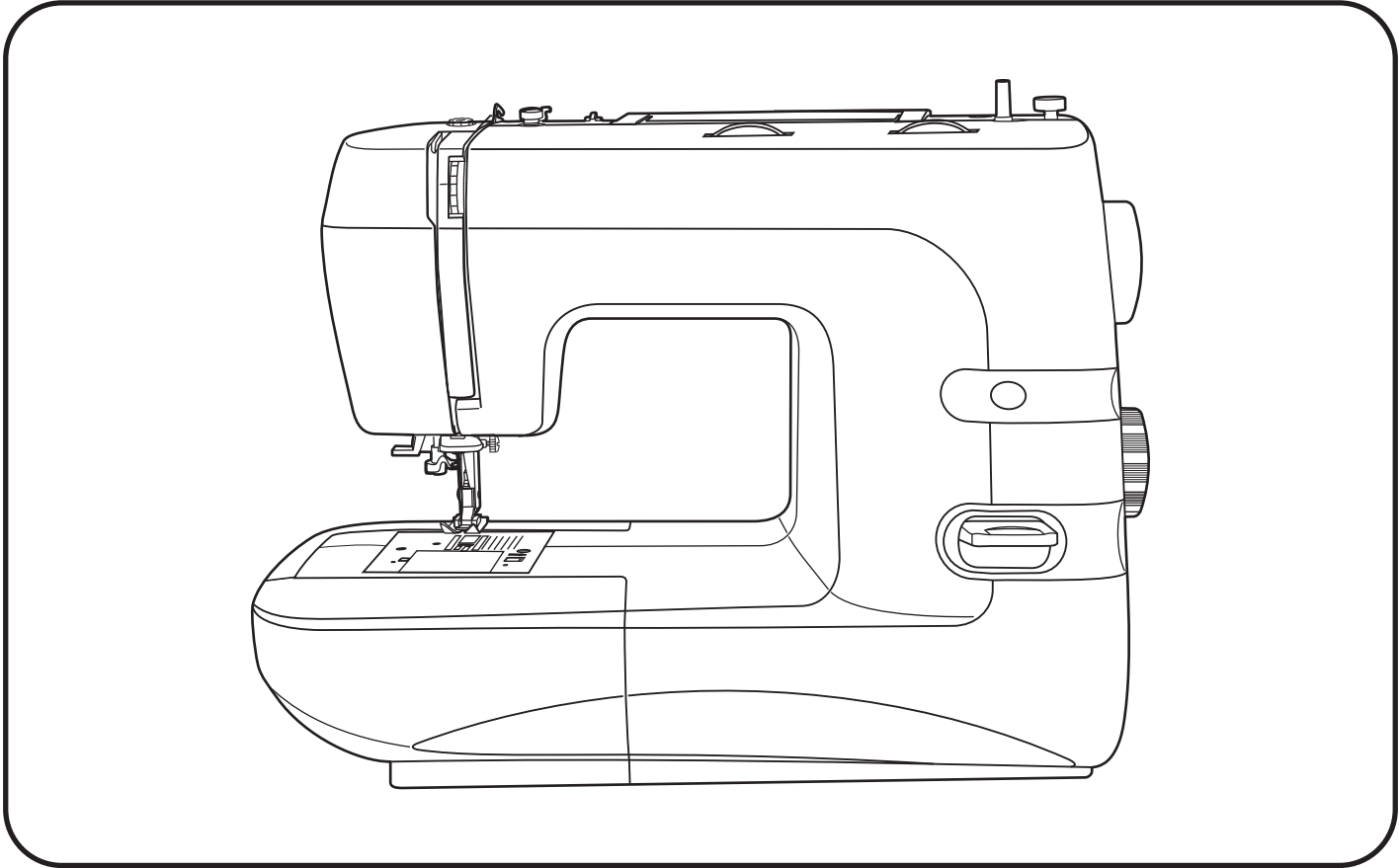

3. Names of principal parts

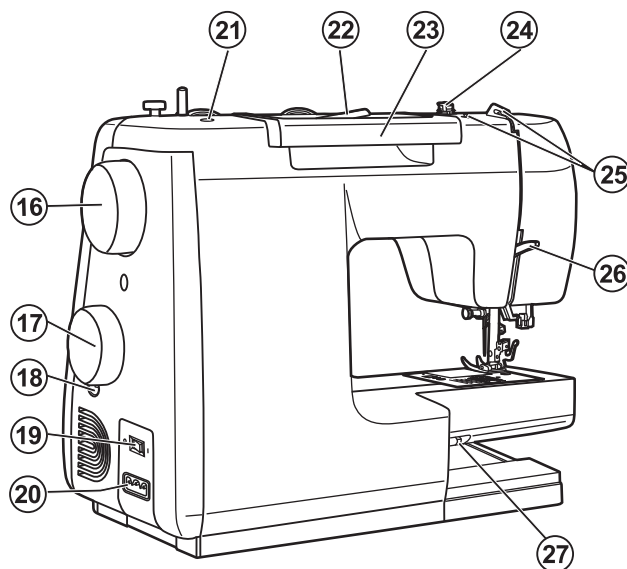
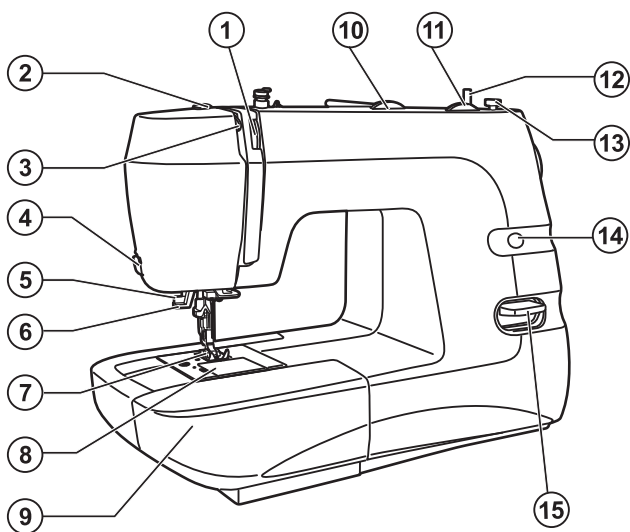

1. Tension dial
2. Presser foot pressure
3. Thread take up lever
4. Thread cutter
5. One step buttonhole lever
6. Automatic threader
7. Presser foot
8. Needle plate cover
9. Sewing table and accessory box
10. Stitch width dial
11. Stitch length dial
12. Bobbin winder spindle
13. Bobbin winder stopper
14. Stitch display

15. Reverse lever
16. Handwheel
17. Pattern selector dial
18. Buttonhole balance control dial
19. Main switch
20. Main plug socket
21. Hole for second spool pin
22. Spool pin
23. Handle
24. Bobbin thread guide
25. Upper thread guides
26. Presser foot lever
27. Drop feed control

4. Removing methods of external parts

4-1 Sewing table

Remove the sewing table. (1)



4-2 Face plate

Remove screw (a) and remove the face plate.(2)

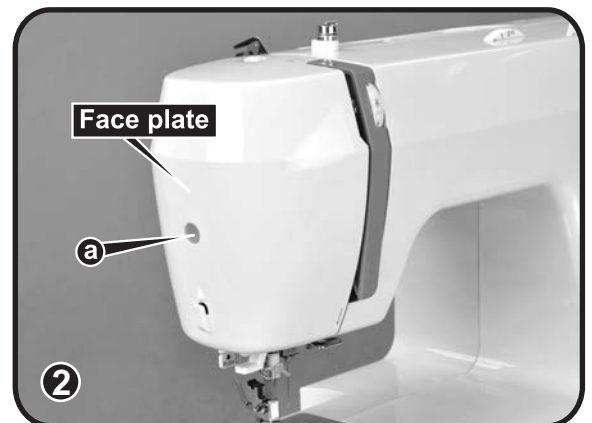

4-3 Cord reel cover

- Lay down machine. Remove 1 cushion rubbers (b).
- Remove 4 screws (c, d, e, f). (3)
- Remove cord reel cover.

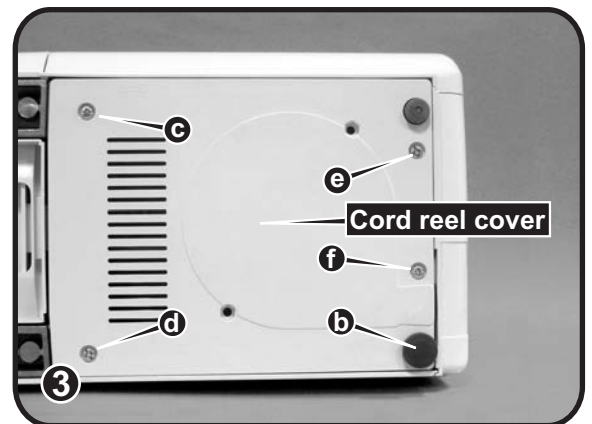

4-4 Belt cover

- Remove the screw (g).
- Remove the patten selector dial
- Remove belt cover. (4)

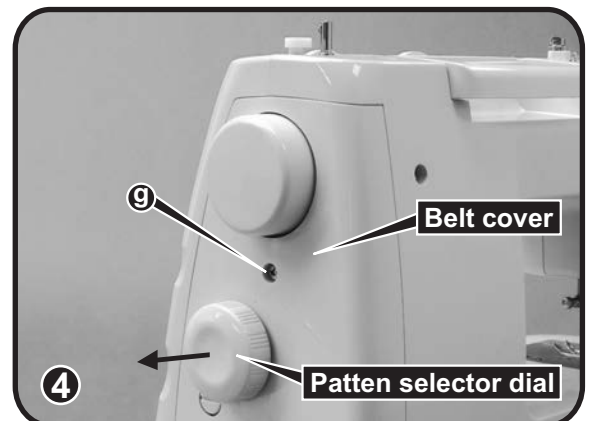

4-5 Free arm foot bush

Remove 4 screws (h, i, j, k) and remove the free arm foot bush. (5)

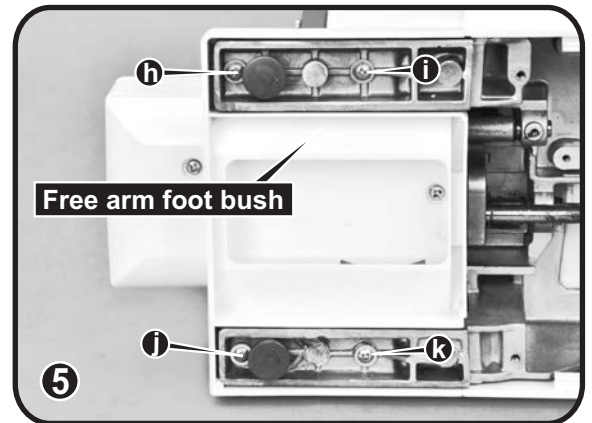

4-6 Free arm cover

Remove 2 screws (l, m) and remove the free arm cover. (6)

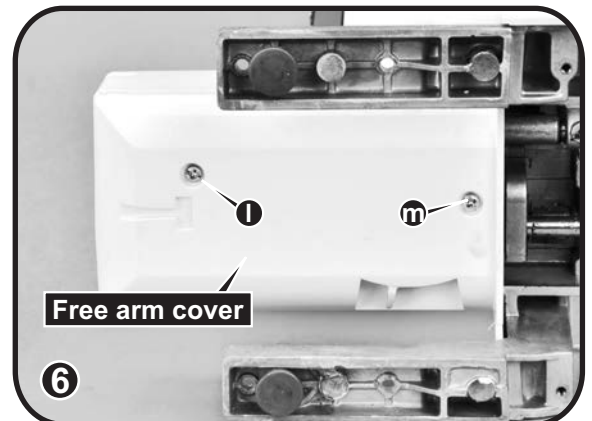

4-7 Front cover

- Remove face plate, arm top cover, sewing box complete, cord reel cover, belt cover, and free arm cover and free arm foot bush first.
- Lift handle and remove 2 screws (n, o). (7)

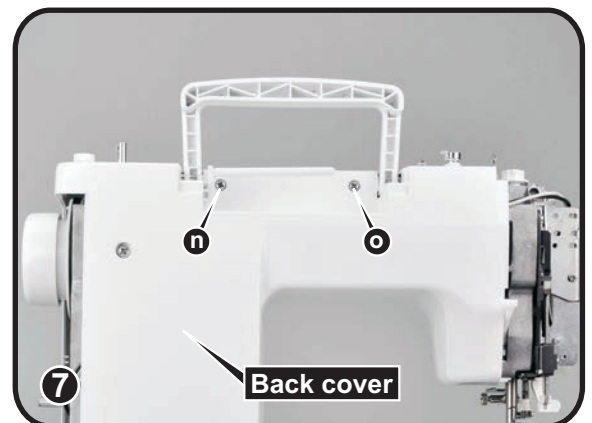

- Loosen screw (p) about 3mm. ---(8)

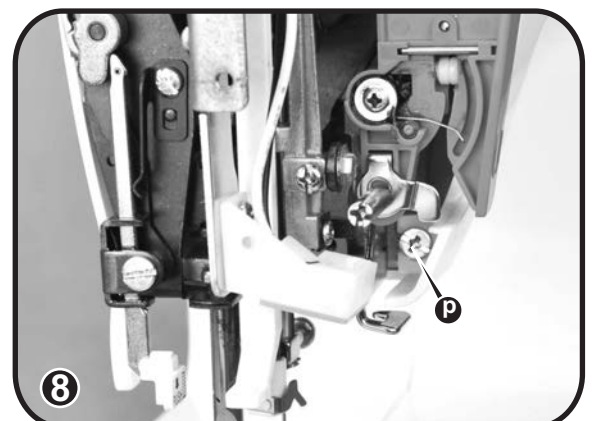

- Loosen screw (q) about 3mm. (9)

Note 1:

First using electric torch (flash light) etc to locate screw (q) position which deeply inside the machine.

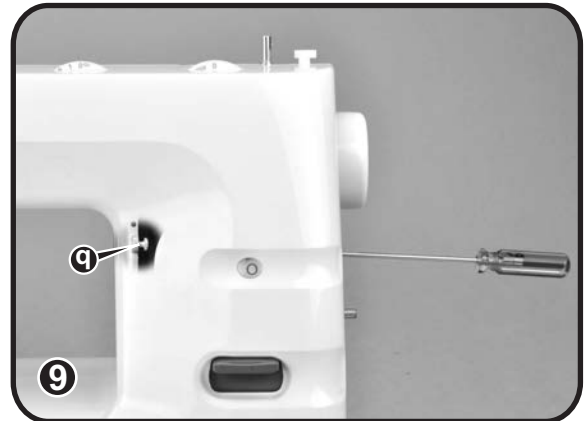

Note 2:

To reach the screw (q), use Philips type screwdriver through the operation hole on plate. (10)

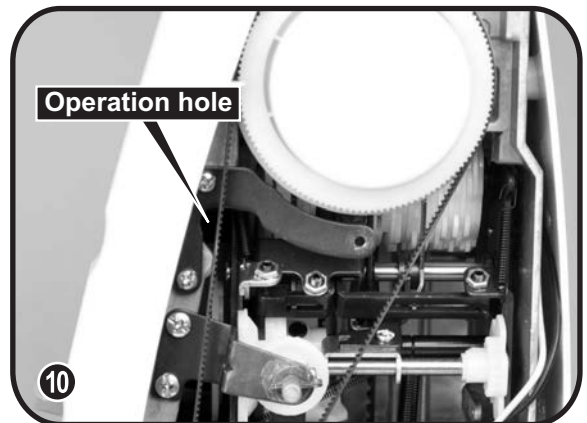

- Remove screw (r). (11)

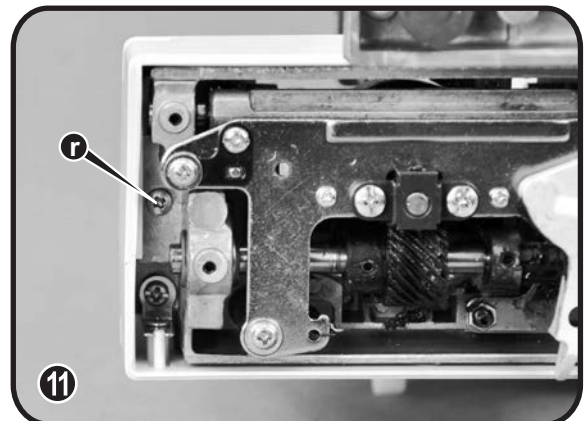

- Remove front cover following direction of arrow. (12)

Attention:

Be sure to remove the front cover carefully, because the leader wire and the body are connected together.



4-8 Back cover

- Remove 2 screws (s, t). (13)

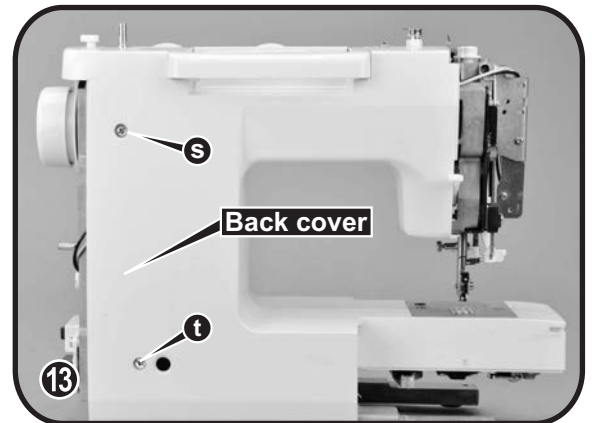

- Loosen screw (u) about 3mm. (14)

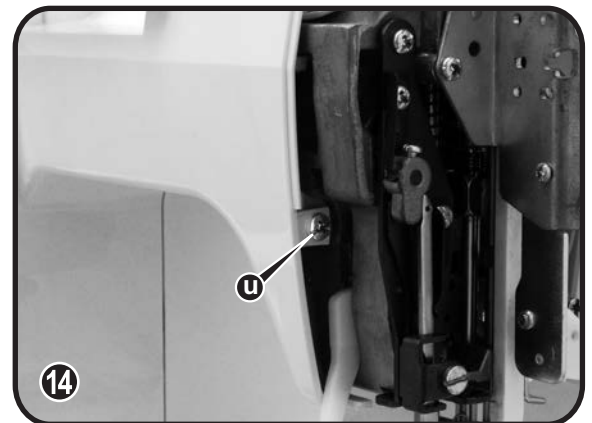

- Remove screw (v).
- Loosen screw (w) about 3mm.
- Remove the back cover. (15)

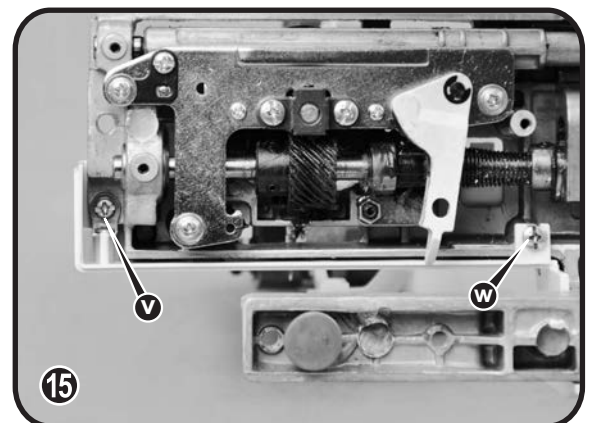

5. Adjusting methods of each part

5-1 Symbol instructions



Noise occur while the machine is running.



Skip-over stitching, needle breakage, and problems associated with needle.



Delivery of cloth to be in disorder and insufficient, problems associated with delivery amount.



Stitch tightening problem.



BH right and left stitching is not even, incorrect length and problems associated with buttonhole sewing.



Bobbin winding problem.

5-2 Play of arm shaft

- Remove the face plate and arm top cover.
- Remove the 2 screws (a, b) of arm shaft collar (A). ---(1)
- Pull hand wheel backward.
- Push arm shaft collar (A) to left tightly against arm shaft bushing (B), and then fasten and secure screws (a, b). ---(1)
- Be sure proper distance between arm shaft collar and arm shaft bushing. ---(2)
- Be sure arm shaft operates smoothly after adjustment.
- Arm shaft collar and arm shaft bushing being too tightly closed might cause insufficient operation of arm shaft.
- Follow step, in order to re-adjust.

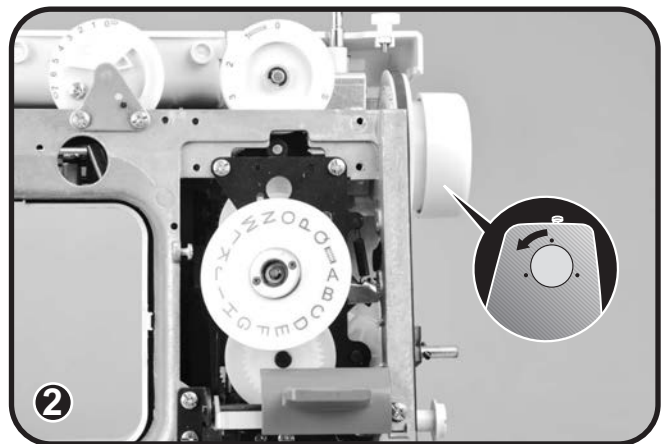
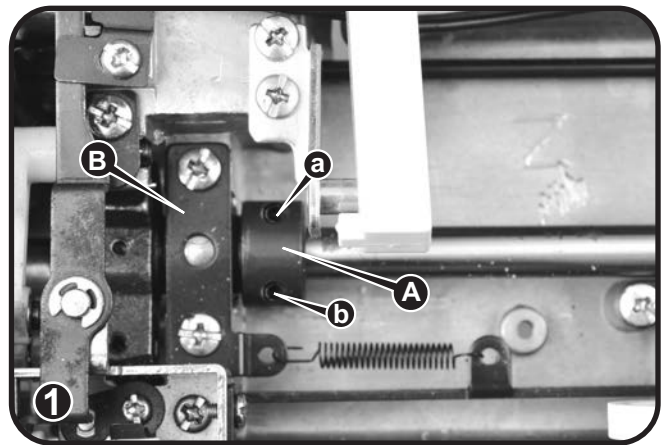

5-3 Drop middle point of needle

 - Choose patterns | , zigzag 0 mm.

- Remove face plate.
- Loosen screw (a) of needle bar supporter.
- Turn needle bar supporter (A) forward / backward to adjust needle.
Backward = to move needle forward
Forward = to move needle backward
- Set needle position above center of needle plate and fasten screw (a).

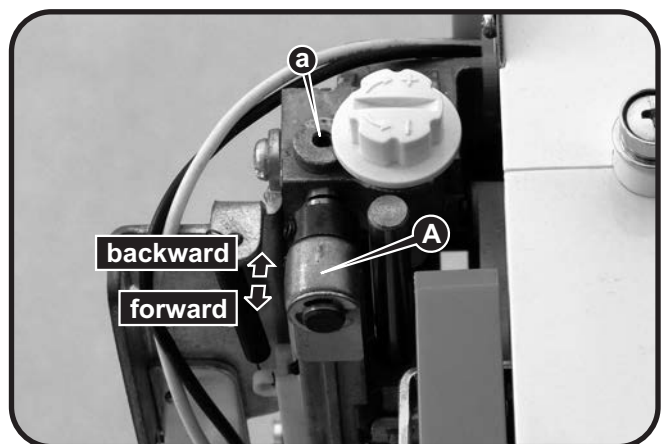

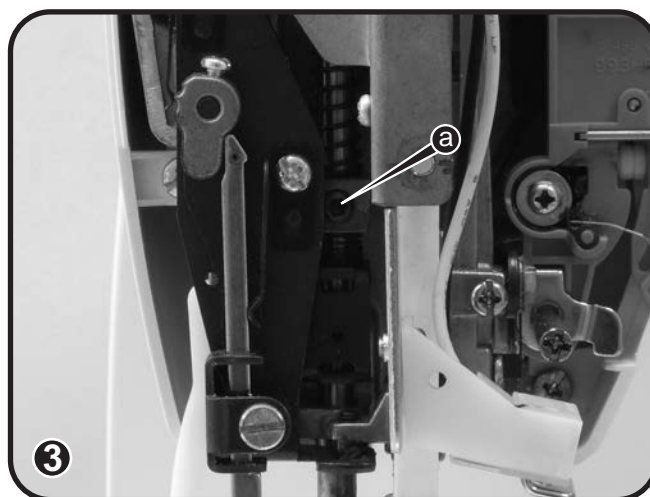
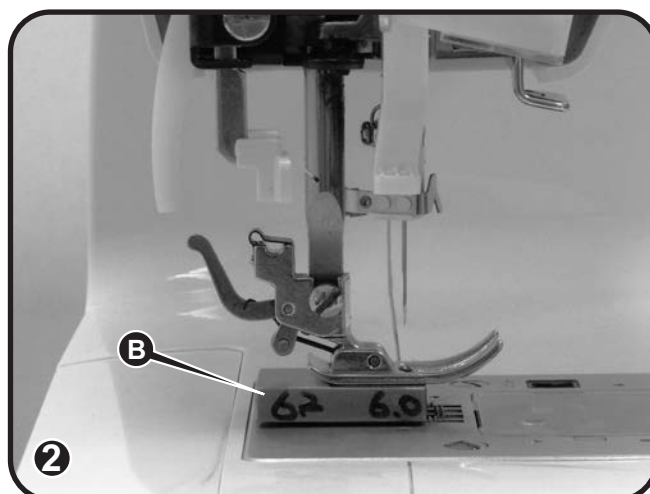

5-4 Height of presser foot

- Remove face plate and lift up presser bar lifter lever (A). ---(1)
- Place gauge (B) (6.0~6.2mm) on top of needle plate. ---(2)
- Loosen screw (a) of presser bar bracket. ---(3)
- Pull down presser bar lifter lever so bottom of presser foot and top surface of gauge would meet.
- Secure tightly screw (a).
- The correct setting of gauge should be 6.0~6.2mm.



5-5 Needle flow at maximum zigzag width



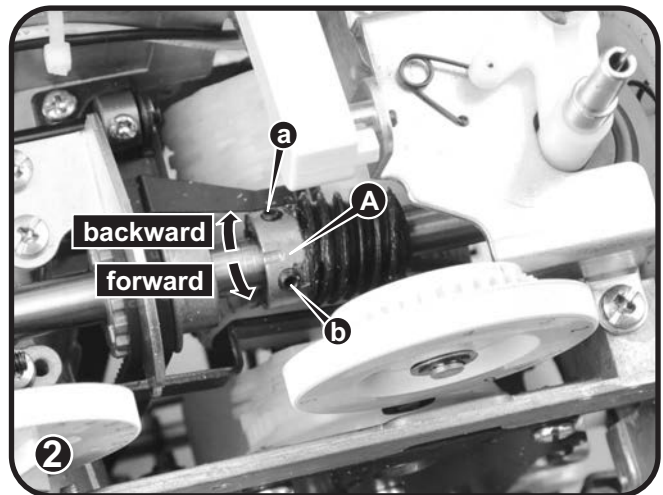
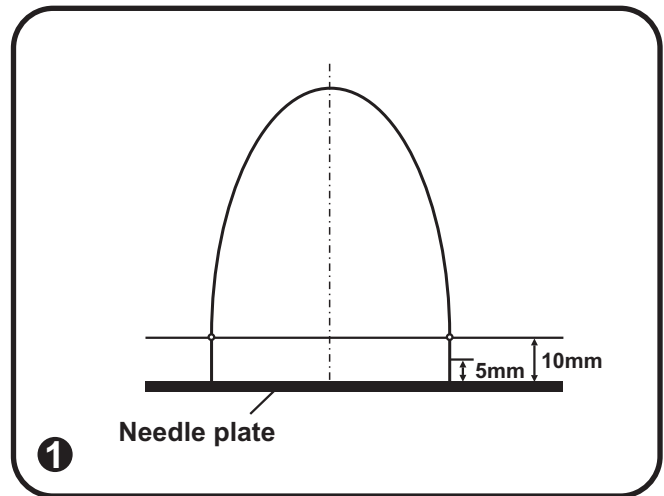

 - Choose patterns , zigzag 7 mm.

- Remove arm top cover.
- Set needle bar at its lowest point when it swings to left. Turn hand wheel to move the needle bar upward. The vertical distance in which the needle point goes up at the left position from the top of the needle plate should be 3~5mm. ---(1)
- If needle flow is less than 3 mm, loosen the screw of arm shaft worm (a, b) to turn arm shaft worm (A) backward (↑). ---(2)
- If needle flow is more than 5mm, turn arm shaft worm (A) forward (↓). ---(2)
- Tighten the screw (a, b) after making sure the needle flow is between 3mm to 5mm.



5-6 Drop middle point of needle

 - Choose patterns  , zigzag 0 mm.

- Remove face plate.
- Loosen screw (a) of needle bar driving rod pin (b). ---(1)
- Adjust needle by pushing (b) clockwise / counter-clockwise.
- Make sure needle drops on middle of needle hole. After adjusting, re-tighten screw. ---(2)

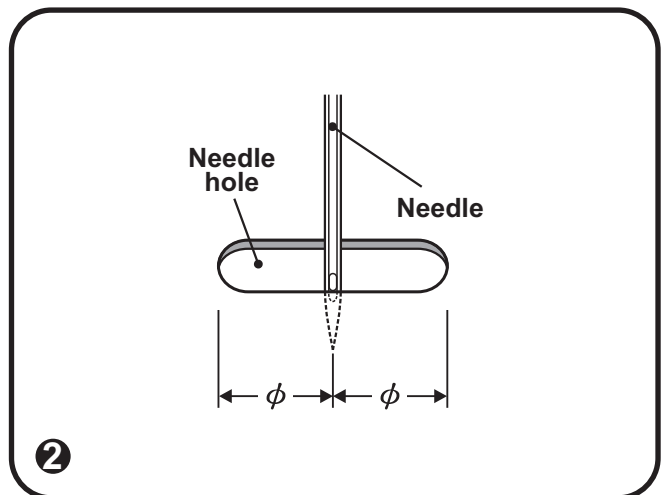
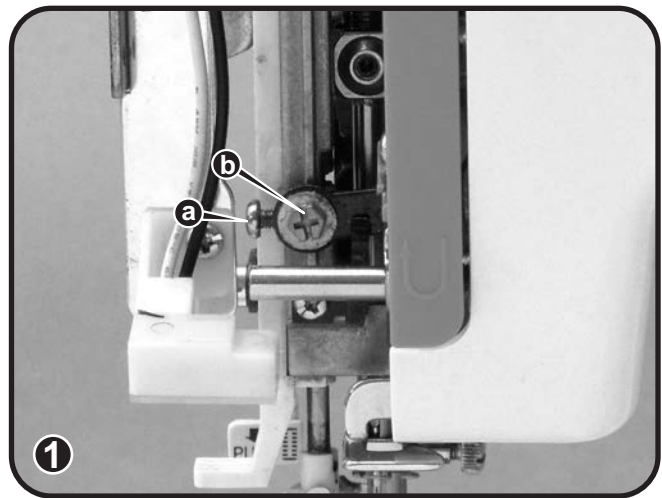

5-7 Needle position of zigzag

 - Choose patterns , zigzag 7 mm.

- Remove face plate
- Loosen screw (a) of needle bar driving rod pin. ---(1)
- Adjust needle by turning (b) clockwise / counter-clockwise.

Clockwise = left

Counter-clockwise = right

- Make sure needle drops on left / right of needle hole with even distance to the edge of needle hole, and then fasten the screws (a). ---(2)
- After the adjustment of z/z needle position, re-confirm the needle position of zigzag.

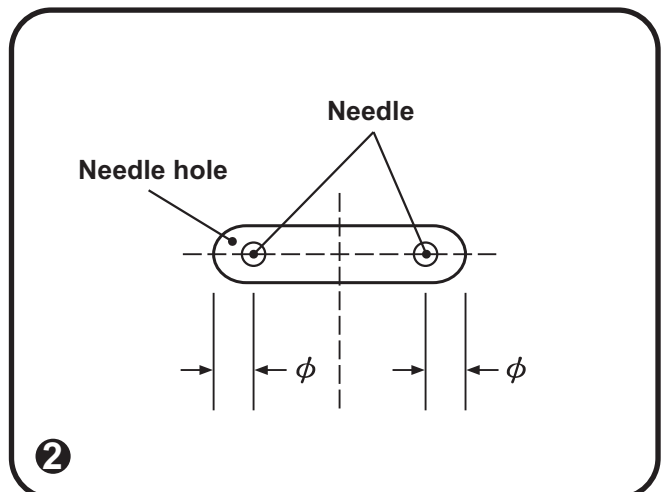
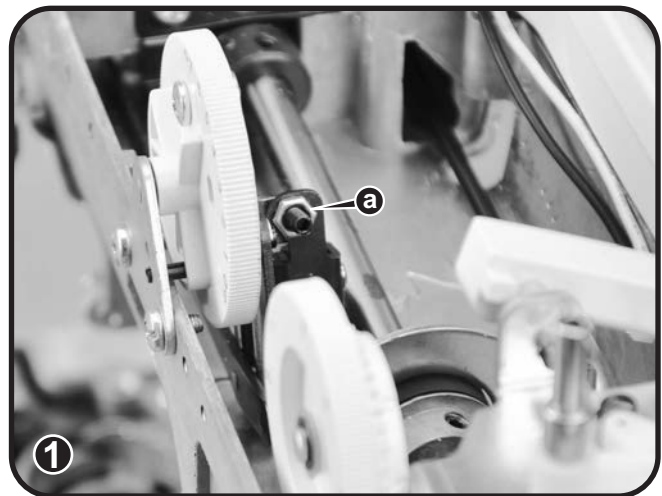

5-8 Automatic needle threader adjustment



- Check the threader hook.
If it is damaged, change new one.
If it is inclined, adjust the threader hook properly.
- If the threader hook can not enter needle hole freely, please adjust the threader stopper. (1)
- Adjust the stopper: (2)
 - i. Remove face plate and turn hand wheel to raise needle bar to its highest position.
 - ii. Loosen screw (a) of the threader stopper (A).
 - iii. Move the stopper (A) upward and the threader hook will become higher.
Move the stopper (A) downward and the threader hook will become lower.
 - iv. Adjust the stopper to the proper position for entering needle hole freely.
 - v. Fasten the screw (a).

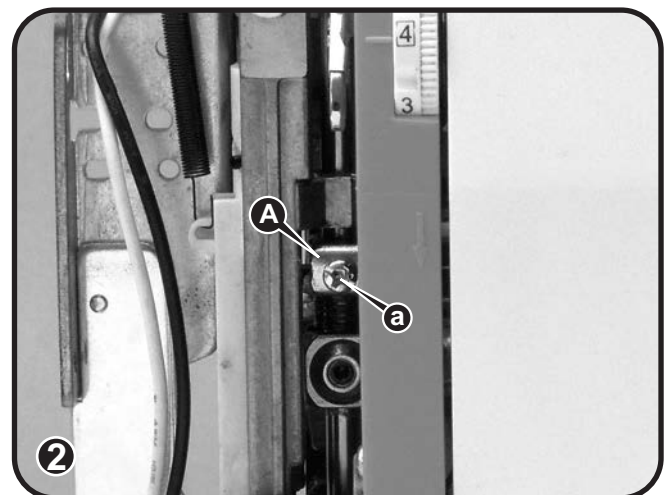
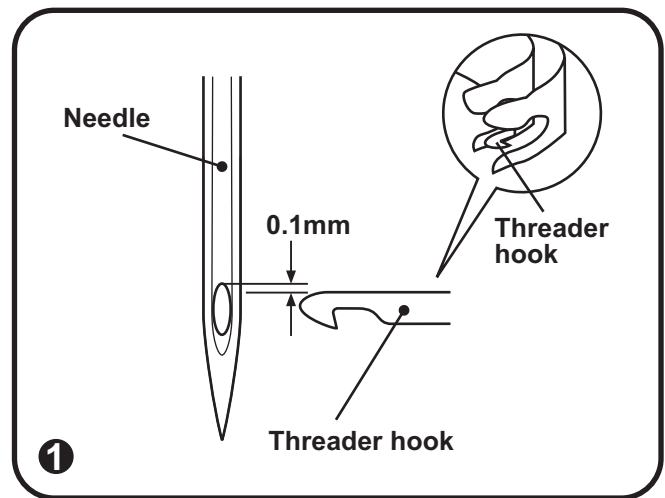

5-9 Adjustment of feed rock shaft and feed lifting rock cam



- Remove cord reel cover, free arm base and free arm foot bush.
- Turn the hand wheel to make the needle rise to its highest point.
From this position on the feed should still shift another 0.5-1mm before stop. (1)
- Check the lower shaft bushing inner screw (a), feed rock cam inner screw (b) on the same horizontal.
Check the screw (c) of feed rock cam must be lower 1 mm than the screw (b) of feed rock cam. (2)
- If not:
Loosen the screw (b) of feed rock cam and adjust the screw (b) to be paralleled with the screw (a).
Loosen the screw (c) of feed rock cam and adjust the distance to be 1 mm between the screw (b) and (c).

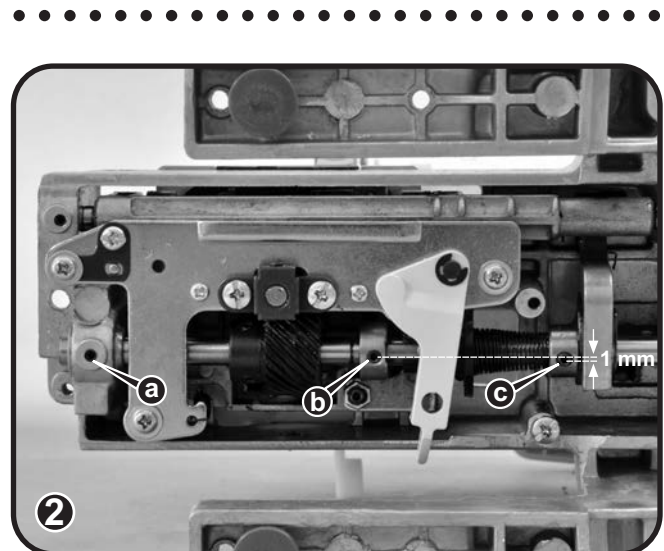
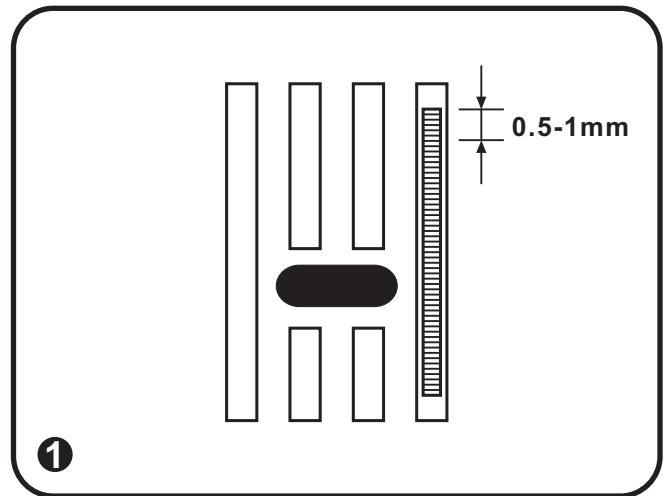



5-10 Height of needle bar

 - Choose patterns | .

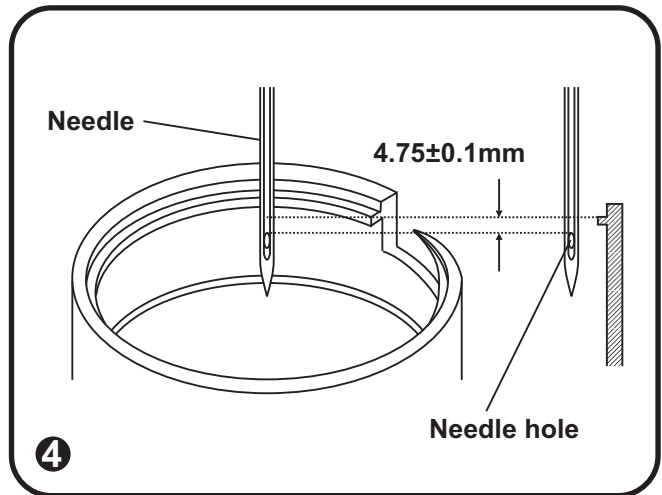
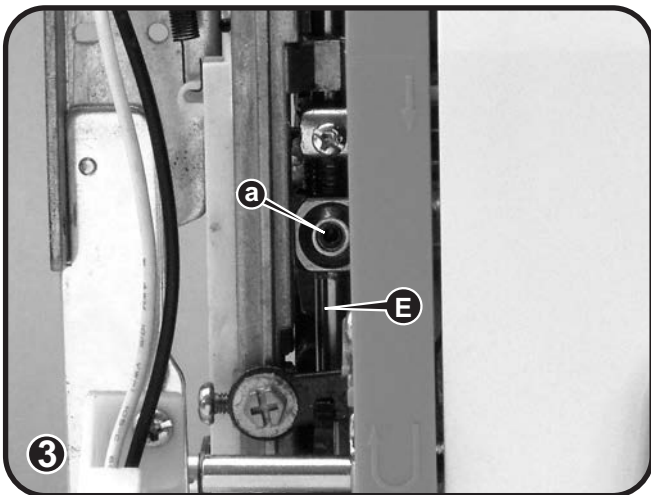
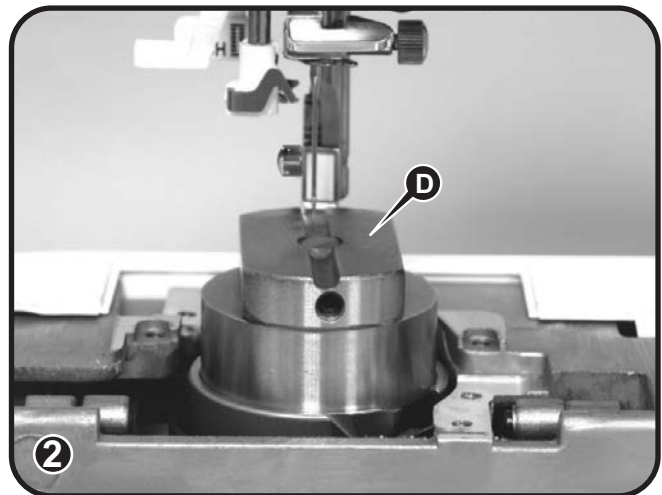
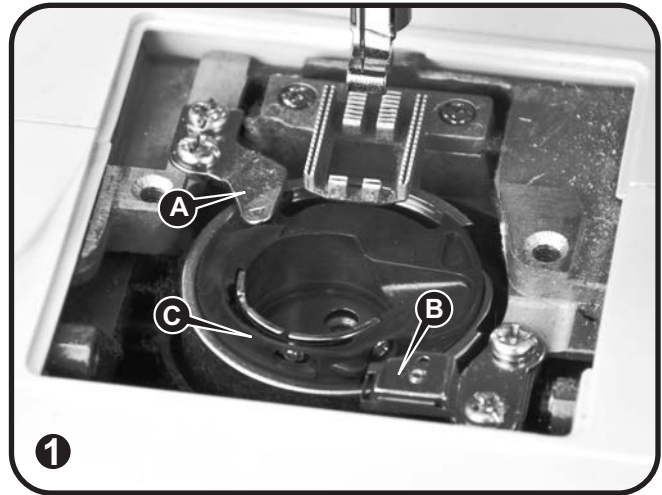
- Remove face plate and needle plate.
- Remove the screws of rotary hook plate (A, B) and rotary hook plate, and take out the shuttle hook.
- Put the gauge of height of needle 25.0~25.1 mm (D) into the shuttle hook holder, and turn the hand wheel to set the needle at the lowest point.
- Turn the gauge of height of needle, and the standard is between 25.0~25.1 mm.
- If it's not fit the standard of measure, loose the needle bar bracket (a) to adjust the needle bar's (E) position for measuring the correct height of needle bar. Lift the needle bar will cause insufficient height of needle bar. Pull down the needle bar, and the height of needle bar will too deep. (3)
- Fasten the screws (a) after confirming the height of needle bar. (When the needle position is on the lowest point, the distance between the top of needle hole and the path of shuttle hook holder should be $4.75\pm 0.1\text{mm}$, refer to iconography 4)
- Re-assemble back the rotary hook plate after adjusting the height of needle bar. Be sure the play of shuttle driver shaft is correct. (Please reference page 21 for examination)



5-11 Timing of needle and hook



 -Choose patterns , zigzag 7 mm.

- Remove face plate, needle plate, shuttle hook, front cover.
- Take out screw (a, b, c), and take apart arm top cover thread guide plate(A).
- Set the needle bar at its lowest point while sewing to the left. Place the clamp of timing adjustment (A) around the needle bar, tighten its screw (d) but still allowing movement by hand. (2)
- Place gauge (Height 4.0mm)(B) between the needle bar support and clamp, move clamp (B) to hold the gauge (C), and tighten screw (d). (2)
- Remove gauge (C), turn hand wheel to lift needle bar till the clamp (B) reach the top. (3)
- Turn the hand wheel until the shuttle hook holder point is on the right side of needle, the distance between needle and hook holder should be 1.1 ~ 1.4 mm. (4)

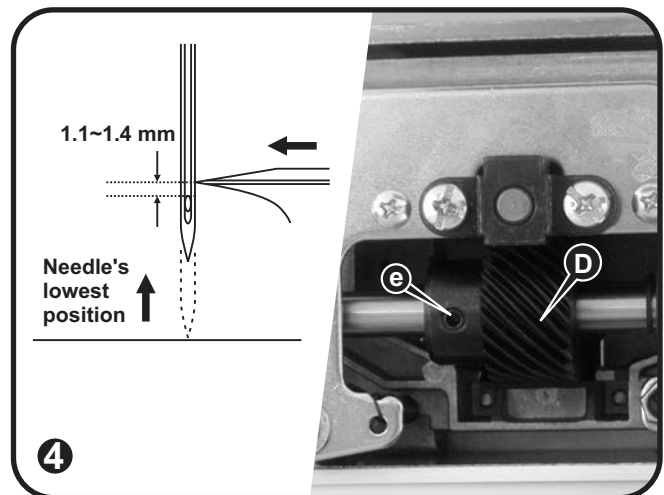
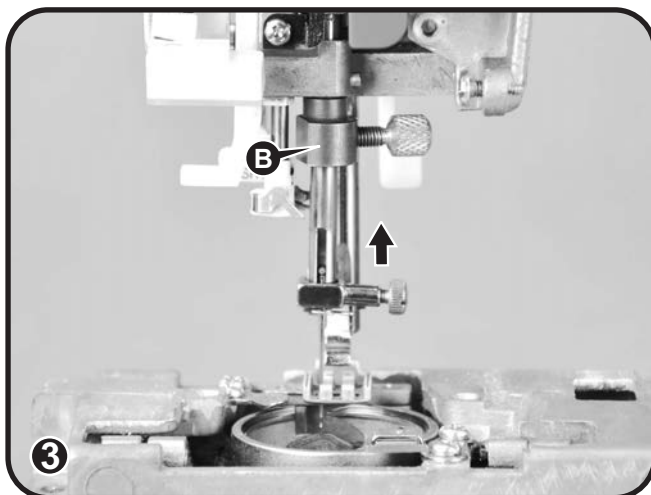
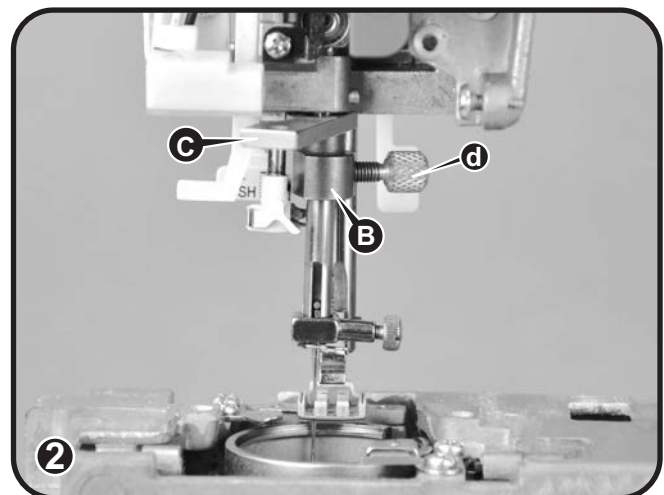
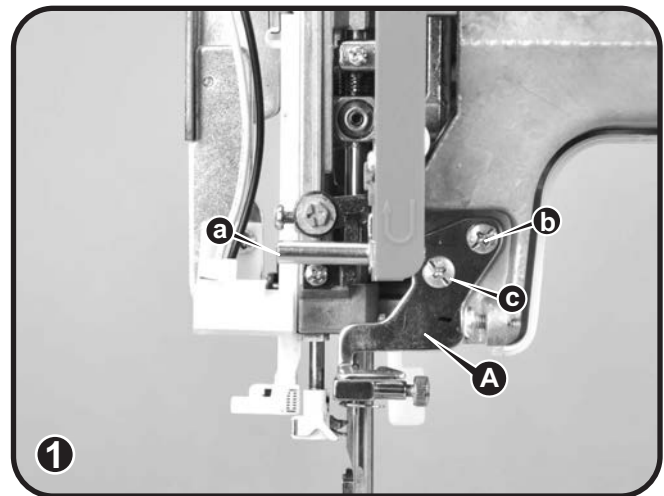
If the distance is incorrect, loosen the 3 screws (e,f,g) of lower shaft gear, and adjust shuttle hook to correct timing, and tighten the screw. (4)



5-12 Distance-needle-hook

 - Choose patterns , zigzag 7 mm.

- Remove face plate and needle plate.
- Take off the shuttle hook.
- Set the needle towards the lowest point of right side and lift it, make sure if space between needle and the tip of the shuttle hook holder should be 0.05~0.1mm. (1)
- If the space is incorrect:

Loosen the screw (a) of the needle bar supporter.

Push the needle bar supporter (A) backward (↑), and the space will become larger.

Push the needle bar supporter toward (↓), and the space will become smaller. (2)

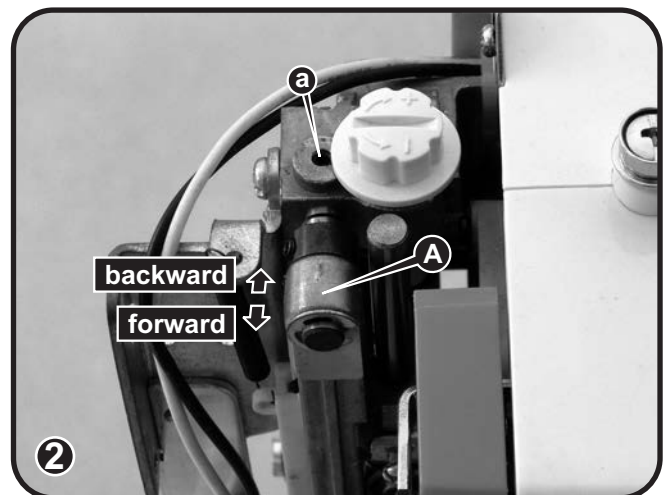
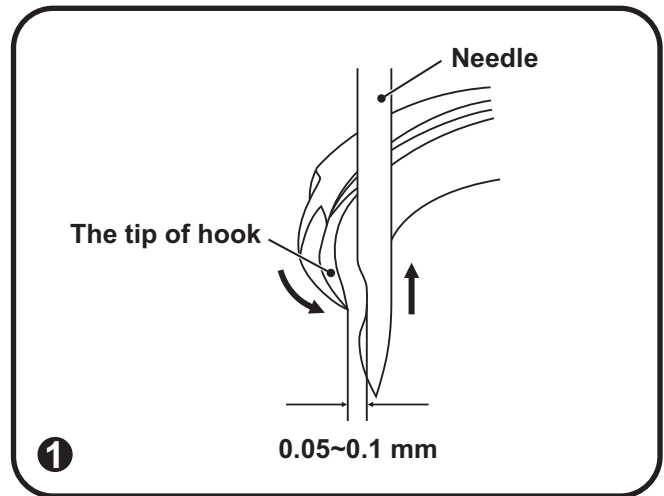

5-13 Play between shuttle driver shaft gear and lower shaft gear

- Remove free arm cover and needle plate.
- Take off the shuttle hook.
- Loosen three set screws (a,b,c) of the lower shaft gear (A) and move the lower shaft gear to right or left against axial direction. (But the lower shaft gear never get out of shuttle hook gear (B).)
- When the playing of the shuttle hook holder should be within 0.5 mm tighten three set screws (a,b,c).
- Make sure match timing of needle and hook. If not, please adjust according 5-11, see page 18.

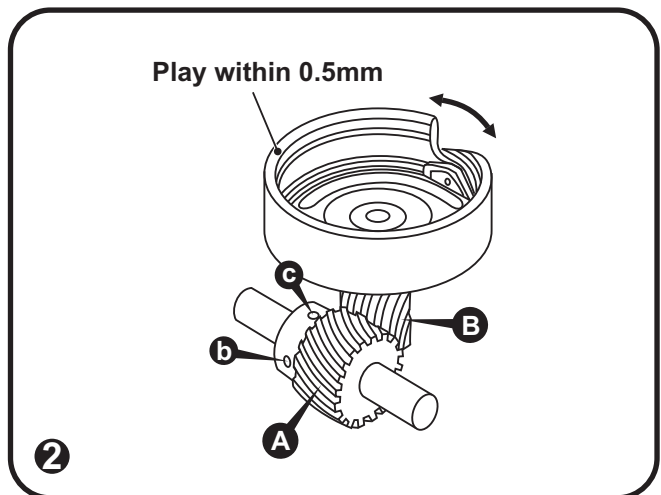
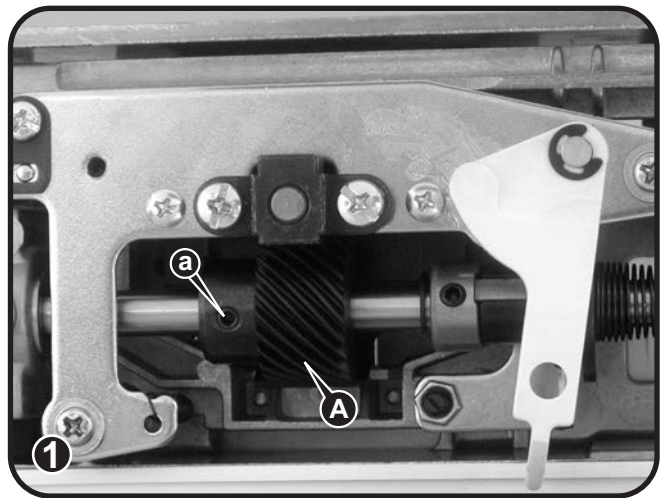

5-14 Play of shuttle driver shaft

- Remove the needle plate.
- There are 2 gauges (A, B) for testing the play of shuttle driver shaft.
- When you turn the hand wheel counter-clockwise, the shuttle hook (C) will move to rotary hook plate (D), and generate the play between the shuttle hook and the rotary hook plate (E).

Using the gauge (A) to test the play, and the standard is 0.3 mm to 0.5 mm.

If the play is incorrect, loosen 2 screws (a, b) of rotary hook plate (E) and adjust the plate to the proper position. Finally, Retighten the screws. (2)

- When you turn the hand wheel clockwise, the shuttle hook (C) will move to rotary hook plate (E), and generate the play between the shuttle hook and the rotary hook plate (D).

Using the gauge (B) to test the play, and the standard is 0.6 mm to 1.0 mm.

If the play is incorrect, loosen 2 screws (c, d) of rotary hook plate (D) and adjust the plate to the proper position. Finally, Retighten the screws. (3)

- Load the needle plate, testing the gap between needle plate cover (F) and shuttle hook (C). Use the gauge (A) to check the gap, the standard is 0.3mm to 0.5mm, if the gap is incorrect, the needle plate cover (F) can be adjusted upward and downward.

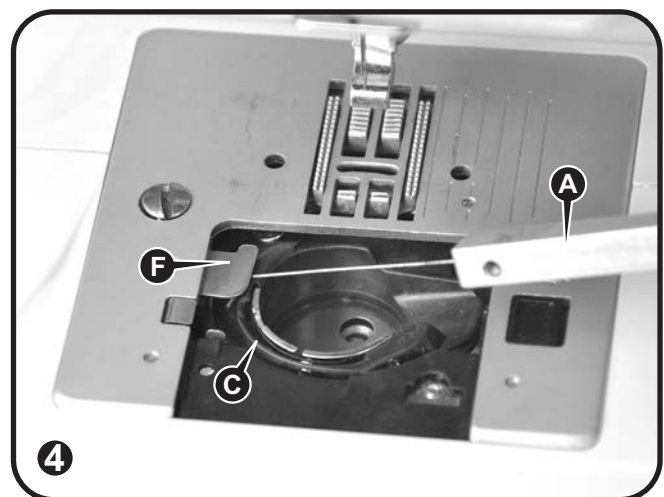
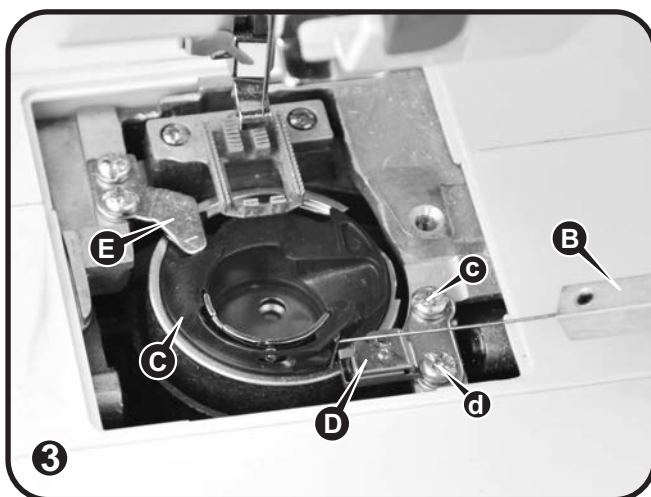
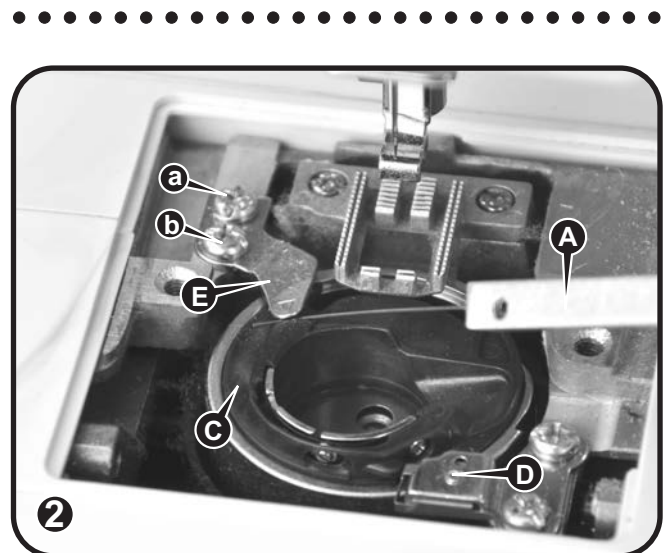
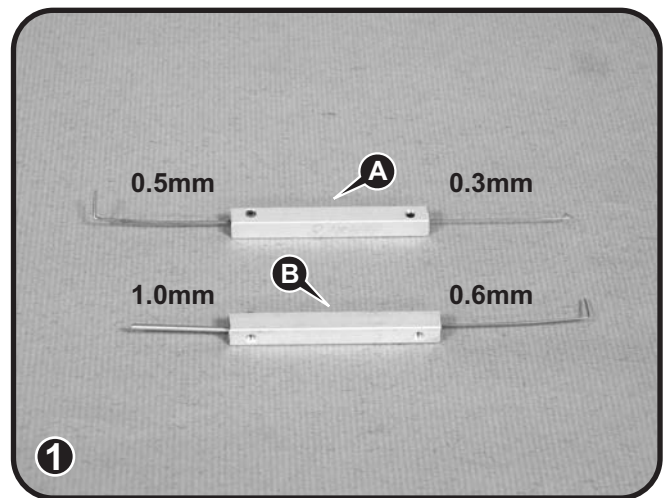

5-15 Feed-dog height

- Remove free arm cover and lift needle to its highest position.
- Remove presser foot.
- Place setting gauge (A) (0.9~1.05mm) on needle plate. The feed dog height then can be checked. (1)
- Press reverse button. At the correct height (0.9mm), the feed dog will be moved freely forward and backward.
- Turn screw (a) of feed rock crank clockwise / counter-clockwise to adjust height of the feed-dog between 0.9~1.05mm. (2)

Clockwise = raise the feed dog

Counter-clockwise = lower the feed dog

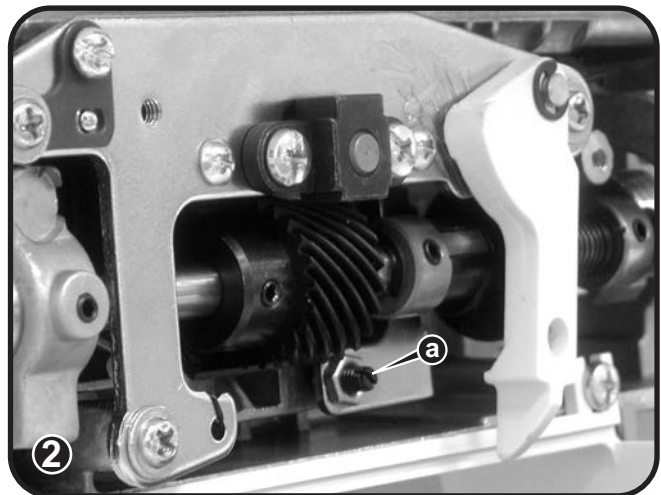
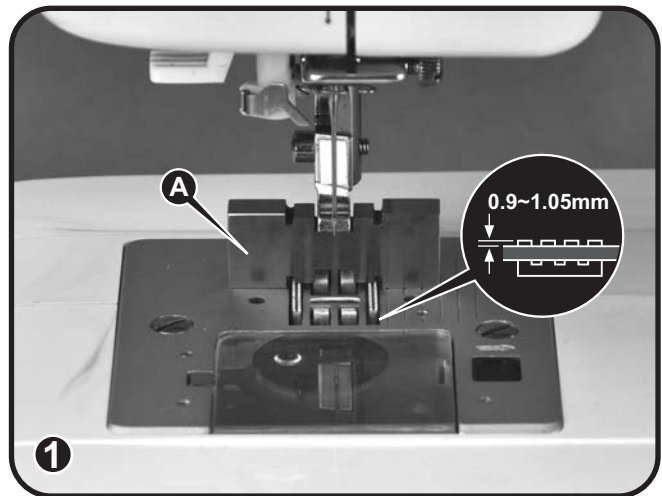

5-16 Position of feed-dog in relation to the needle plate (left to right)



- Remove the free arm cover and free arm foot bush.
- Loosen the screw (a) of the feed crank shaft (A) that is on the right side.
- Loosen the screw (b) of the feed crank shaft (B) that is on the left side.
- Adjust feed dog to center position by moving feed crank shaft (B) left / right in accordance with feed rock shaft (C) left / right. (3)
- Tighten screw (b) to fix the left side of feed crank shaft (B).
- Push right side feed crank shaft (A) to left and fasten the screw (a).

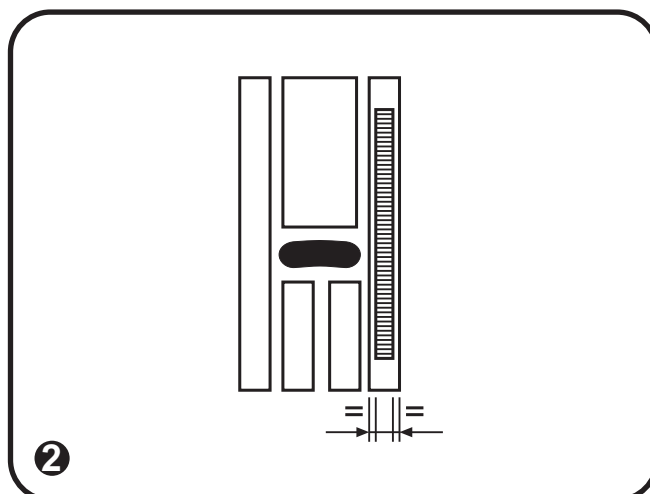
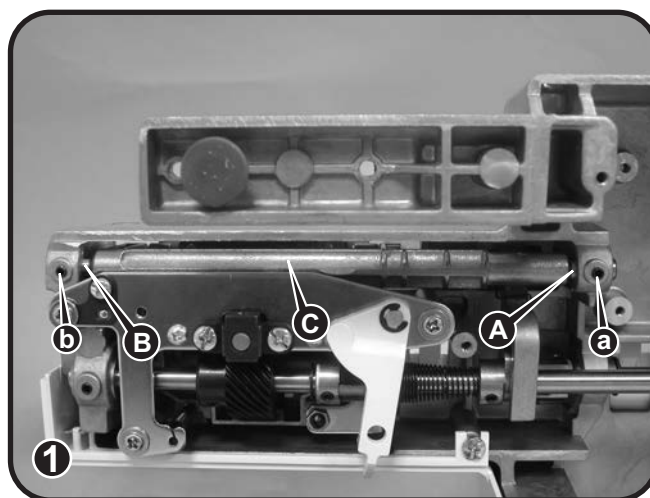

5-17 Upper thread tension adjustment

- Remove front cover and set dial tension to "4".

Use a dial tension gauge (150g) (A) to take measurement.

- Lift the presser foot lever first, and then put the thread of tension gauge into the tension disk. (2)

- Lower the presser foot, and pull down along the threading direction on the cover. The standard range should be 50 ~ 60g. (3)

- Adjust tension by turning plastic screw (a) of dial tension regulator frontward / backward. (4)

Frontward = weaker

Backward = stronger

- Re-check the standard range should be 50~60g.

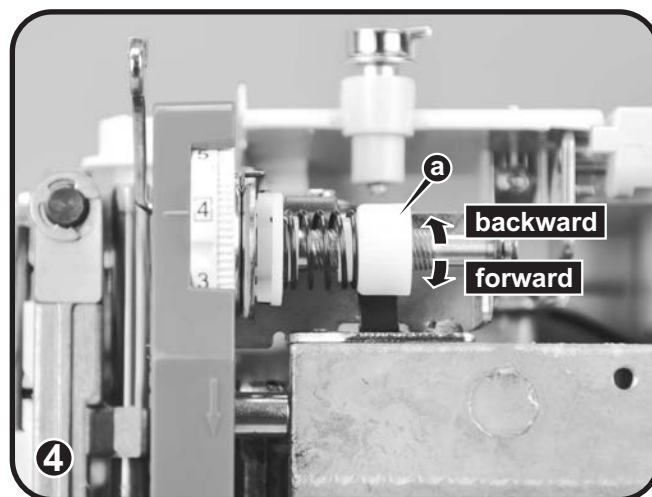
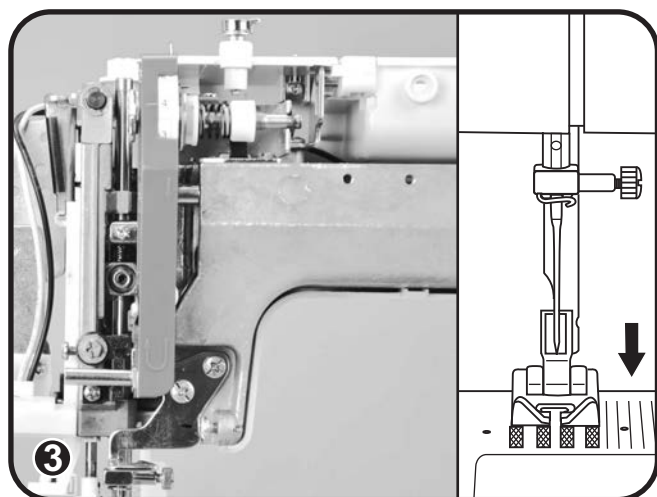
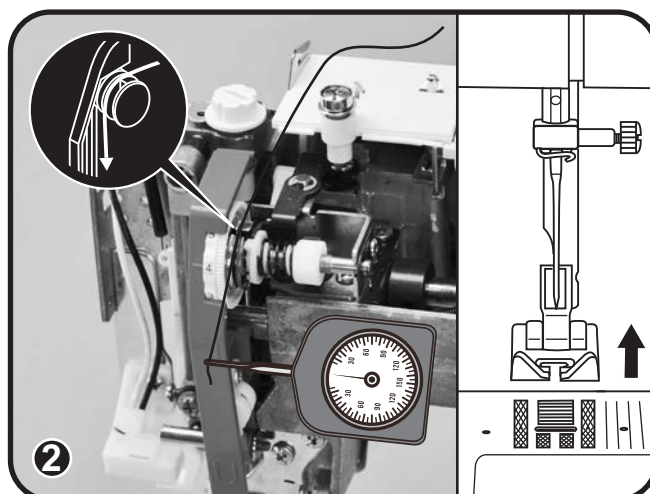
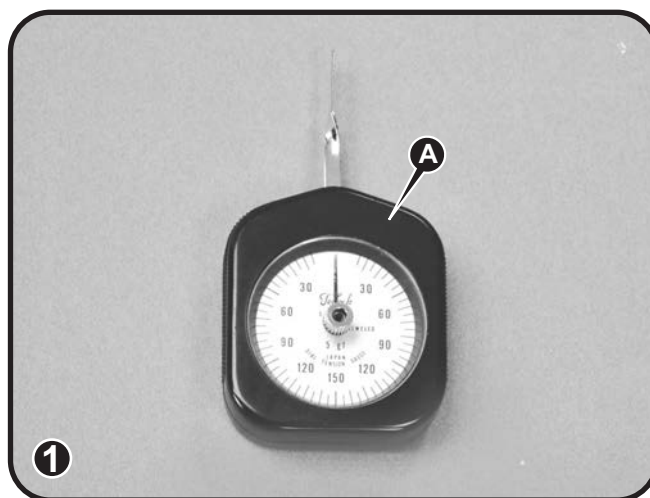

5-18 Shuttle hook tension adjustment

- Remove the needle plate.
- Use a dial tension gauge (50g) (A) to take measurement. (1)
- Put dial tension thread into shuttle hook (the same way as inserting the bobbin) Pull it out, the standard range should be 18~22g. (2)
- Adjust the screw (a) of shuttle hook to correct it if necessary. (3)

Turning clockwise makes dial tension stronger; turning counter-clockwise makes it weaker.

Re-check the standard tension range should be 18~22g.

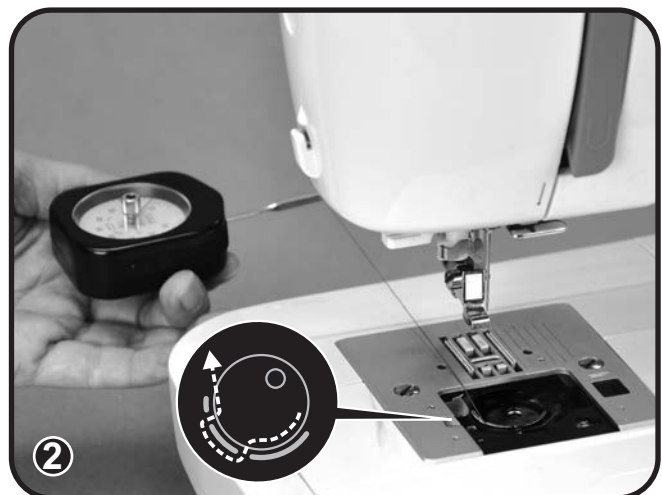
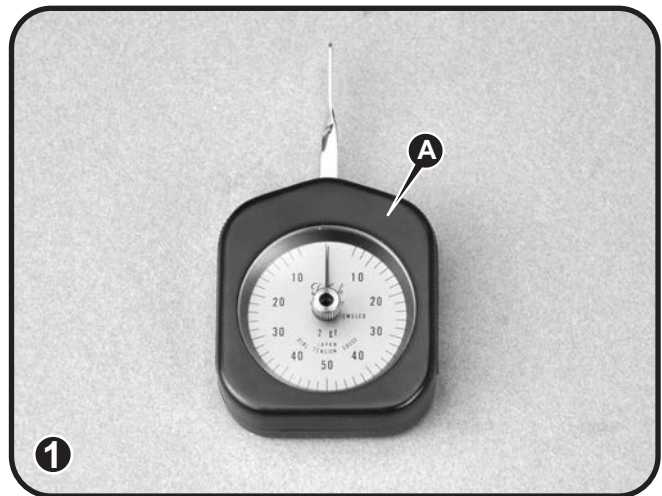

5-19 Motor belt tension



- Remove back cover and test tension of motor belt using belt tension gauge (A). Its standard measurement should be 200g. (1)
- Adjusting the belt adjusting plate (B) to regulate the improper belt's tension. The way to adjust is as following:

Loosen the screw (a) of adjusting plate (B), and then move it to right, the belt will become tighter; move it to left, it will become more loosen. (2)

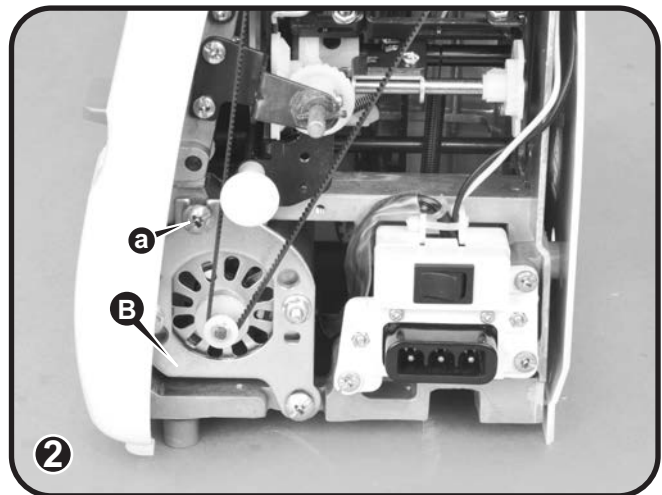
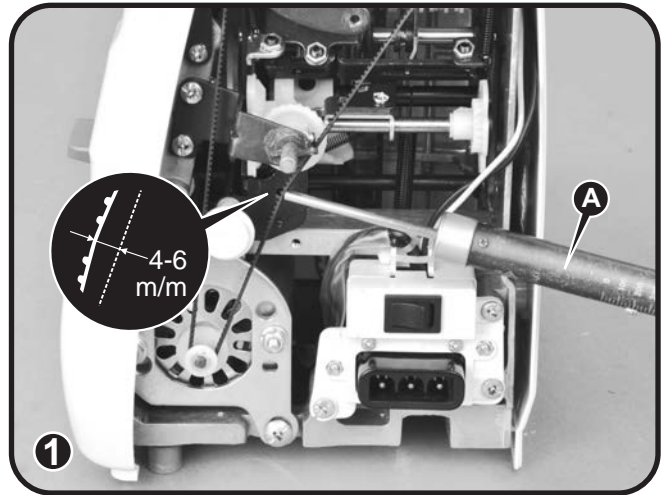
Tighten screws (a) after confirming the proper belt tension.



5-20 Drop point of needle

 - Choose patterns .

- Place a piece of blank paper on top of the needle plate and use presser foot to secure paper by pressing presser bar lifter lever down. (1)
- Adjust the speed limiting adjustment lever to the slow speed and step on the foot controller lightly. Check if the needle can drop in the same place while moving forward and backward. (2)
- If the drop point are not the same, take apart the plate (A). (2)
- If the stitch is too tight, adjust the screw of feed crank (a) anti-clockwise, and the needle will go forward (↓). (3,4)

If the stitch is too loose, adjust the screw of feed crank (a) clockwise, and the needle will go backward (↑). (3,4)

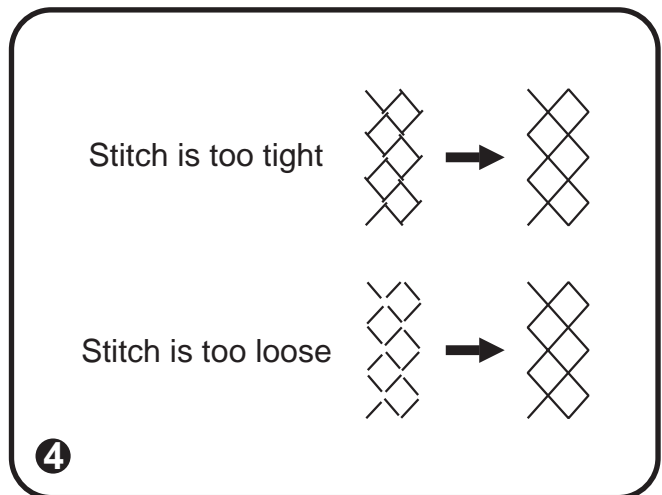
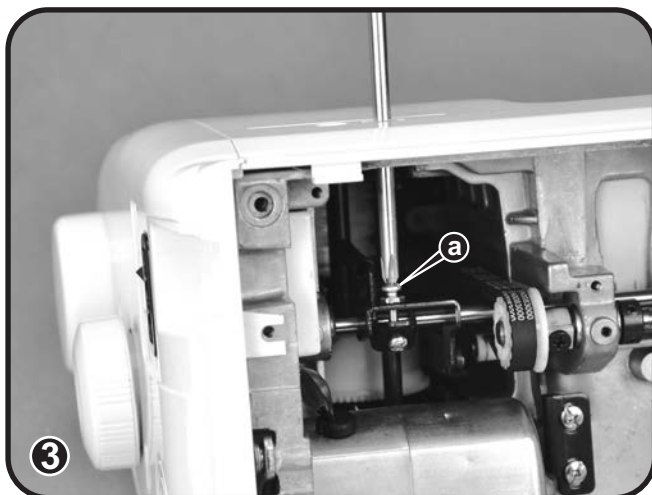

5-21 Forward and reverse stitching in buttonhole sewing (feeding pitch of reverse and forward stitching is not even)



 - Choose patterns .

- Remove belt cover.
- Set stitch length dial at "0.5" to "1".
- To sew by using thread in effect, to confirm delivery amount of forward and backward. (1)

If forward and backward delivery amount not match, adjust by turning screw (a) of pattern cam contact plate clockwise / counter-clockwise. (2)

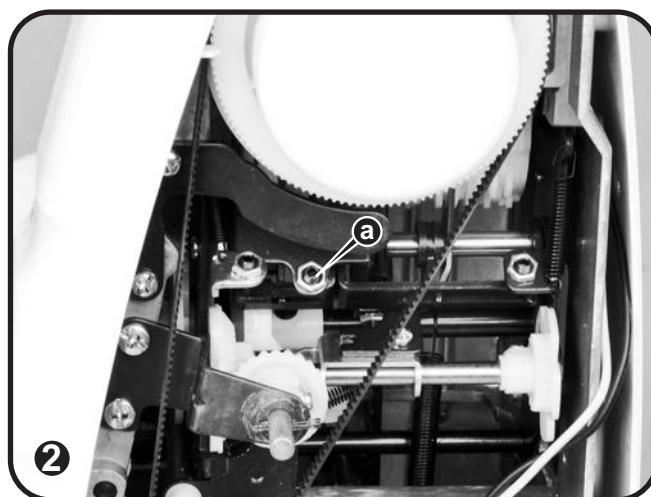
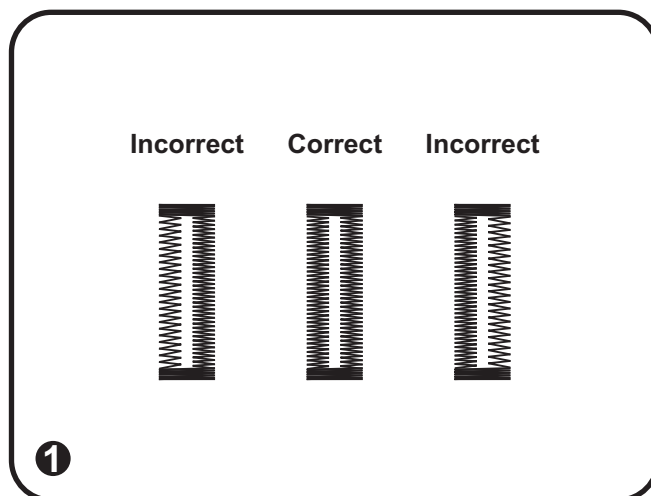

Counter-clockwise = strong

Clockwise = weak



5-22 Bar tack density (stitch advances in upper or lower bar tacking)



 - Choose patterns .



- Remove belt cover.
- Set stitch length dial at "0.5" to "1".
- To sew by using thread in effect, to confirm delivery amount so that buttonhole upper or lower stitching may not advance. (1)
- To adjust by turning screw (a) of BH adjusting lever clockwise / counter-clockwise. (2)

Turning clockwise direction = when lower stitching advances

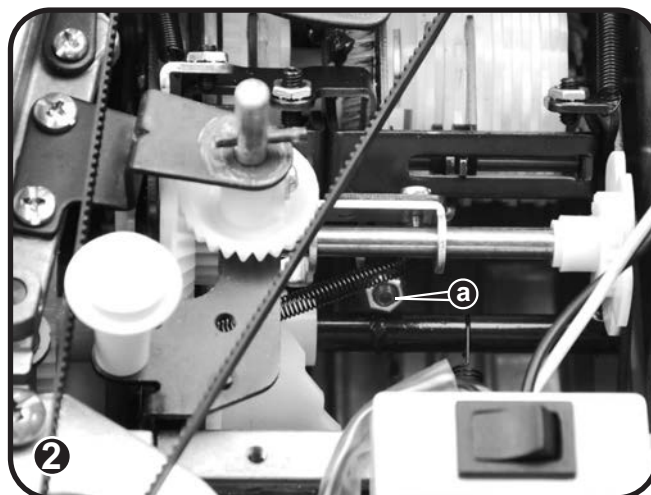
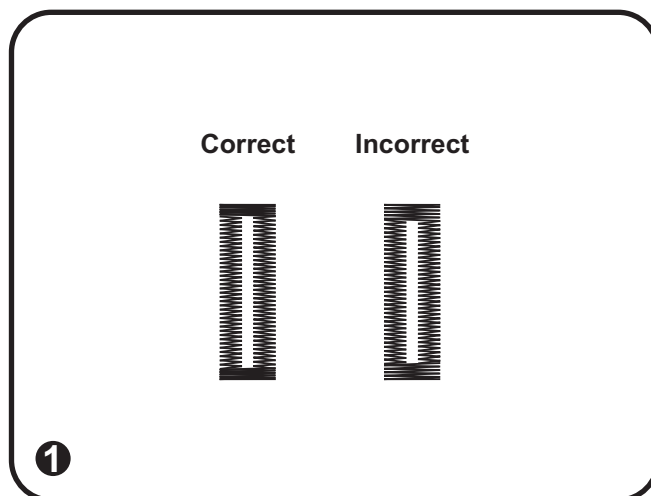
Turning counter-clockwise direction = when upper stitching advances



5-23 Buttonhole length adjustment

 - Choose patterns .

- Remove face plate.
- Set the stitch length dial at "0.5" to "1".
- Place button on needle plate and secure with BH presser foot. To sew by using thread in effect, to confirm if length of BH stitching is equal to length of button. (1)
- Loosen screw (a) of BH positioned plate (A) to adjust length of buttonhole sewing by moving plate (A) downward / upward. (2)

Upward = when buttonhole length too short

Downward = when buttonhole length too long

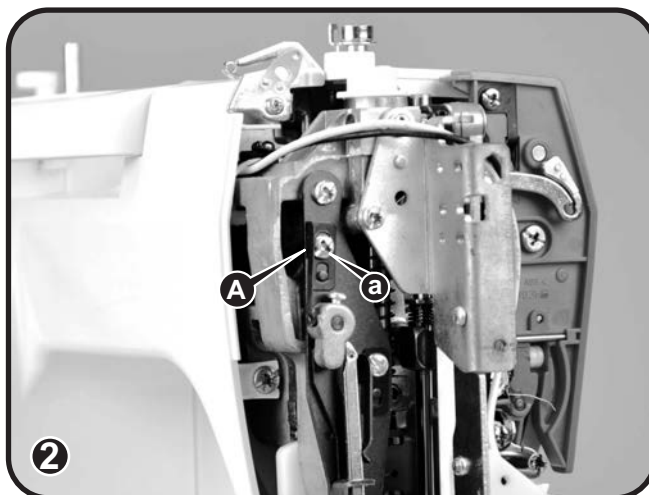
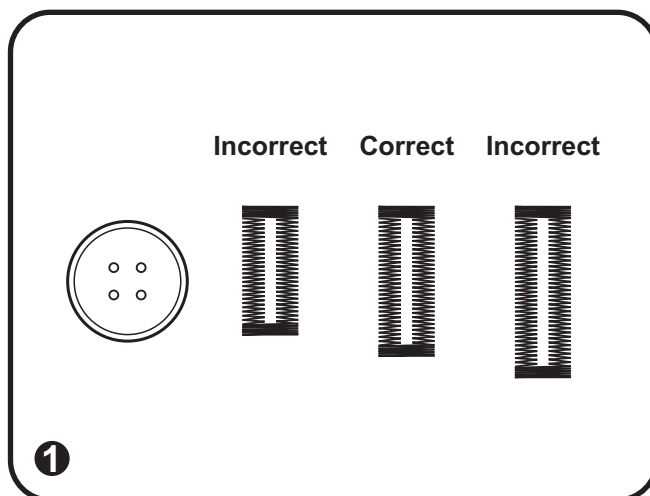

5-24 Bobbin winding problem

- Place empty bobbin on spindle and push it to the right.
- Put the thread into the spool rod, and put the spool rod cover on it.
- Lead thread from spool to back side of thread guide (A) by following the indication.
- Wind thread clockwise around bobbin winder tension disc. (1)
- Turn on the power switch and step on the foot controller to run the machine.
- Observe the shape of bobbin winding:

When the lower part of bobbin winding is thicker, turn the screw (a) of threader guide counter-clockwise. (2)

When the upper part of bobbin is thicker, turn the screw (a) of threader guide clockwise.

- Observe the intensity:

If bobbin winding is not 80 percent full, adjust by turning the screw (b) of bobbin winder bracket shaft clockwise. (3)

If bobbin is over 80 percent full, adjust by turning the screw (b) of bobbin winder bracket shaft counter-clockwise.

- Bobbin should be 80 percent full and evenly filled after adjustment.
- Push bobbin to left after adjustment before sewing.

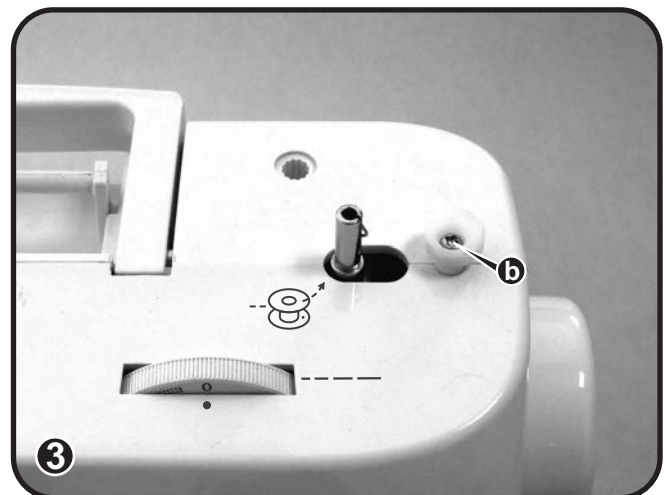
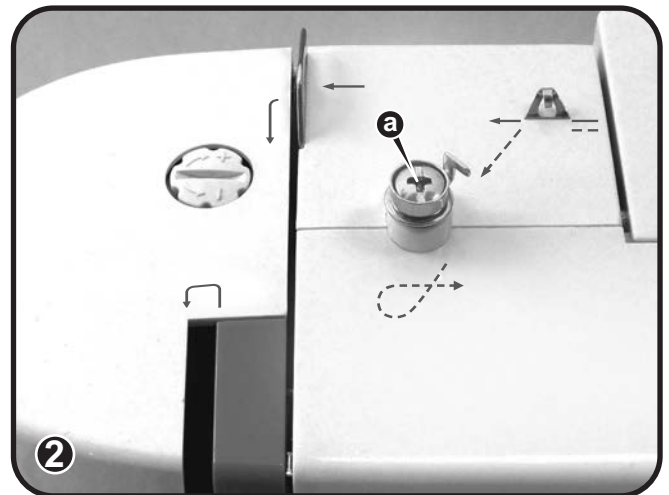
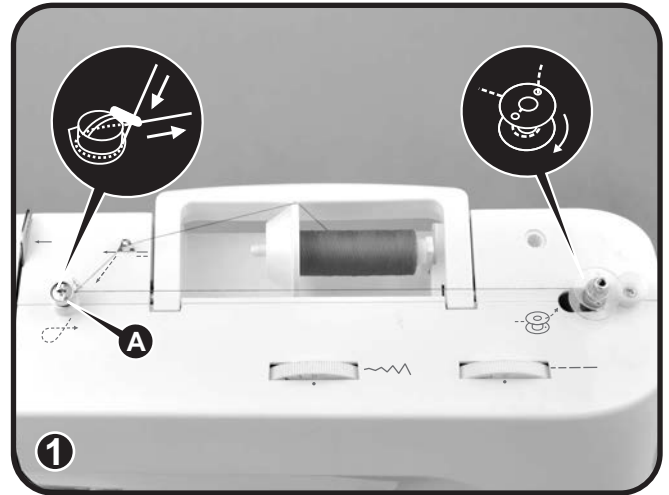

6. Circuit diagram

Europe

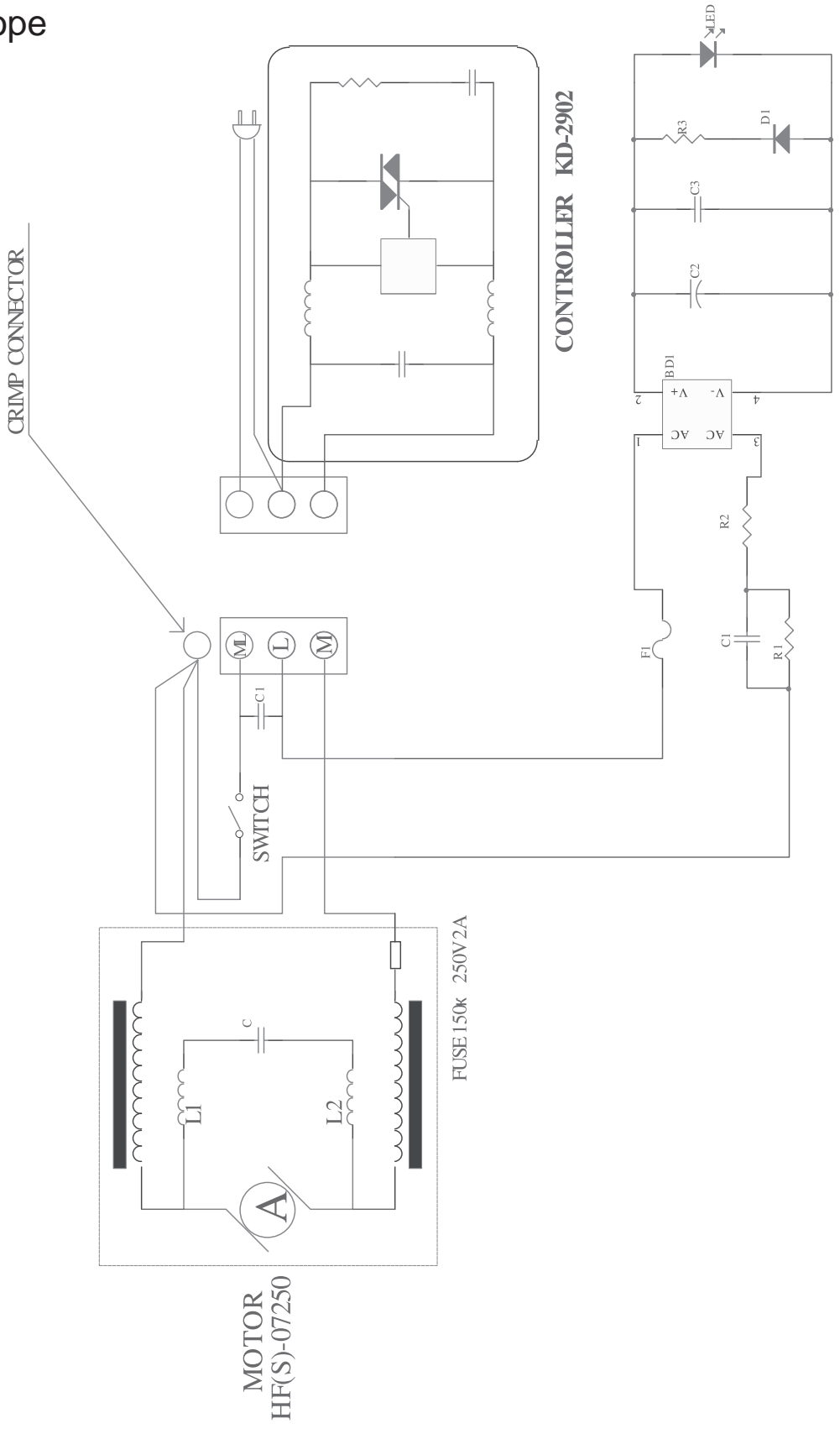

6. Circuit diagram

North America

