

Long Arm, 1-Needle, Unison-Feed, Vertical-Axis Large Hook  
Lockstitch Machine with an Automatic Thread Trimmer  
ロングアーム1本針本縫総合送り水平大釜自動糸切りマシン

# LU-2216N-7

Long Arm, 2-Needle, Unison-Feed, Vertical-Axis Large Hook  
Lockstitch Machine with an Automatic Thread Trimmer  
ロングアーム2本針本縫総合送り水平大釜自動糸切りマシン

# LU-2266N-7

# PARTS LIST

## HOW TO MAKE USE OF THIS PARTS LIST

1. As to "#01" and "#02" refer to the "Note" given at the bottom of the respective pages.
2. Codes on the "Qty" column
  - Each numeral indicates the number of parts required.
  - "0.1" and "2.5" indicate the length (in meters) of the respective parts.
3. Parentheses mean that the corresponding part is a subpart that constructs an assembly part.
4. Dotted lines on the Figures indicate assembly parts.

## パーツリストご利用に際して

1. リストページの#01、#02等の印は、ページ下の"注記"の説明をご参照下さい。
2. 数量欄の数字は、個数を表し、0.1、2.5等の数値は、長さ(単位メートル)を表します。
3. 数量欄の( )は、組部品を構成している子部品であることを意味します。
4. イラストページの-----枠は、組構成であることを意味します。

# CONTENTS

## 目 次

1. FRAME & MISCELLANEOUS COVER COMPONENTS .....	1
頭部・外装関係	
2. MAIN SHAFT,HOOK DRIVING SHAFT DELIVERY & THREAD TAKE-UP LEVER COMPONENTS .....	3
上軸・下軸伝達装置・天秤関係	
3. NEEDLE BAR ROCKING COMPONENTS .....	5
針棒揺動関係	
4. UPPER FEED MECHANISM COMPONENTS .....	7
上送り関係	
5. FEED ADJUSTMENT & REVERSE FEED MECHANISM COMPONENTS .....	9
送り調節・逆送り関係	
6. LOWER FEED MECHANISM COMPONENTS .....	11
下送り関係	
7. RIGHT HOOK SHAFT BASE THREAD TRIMMER COMPONENTS .....	13
右釜軸台糸切り関係	
8. LEFT HOOK SHAFT BASE THREAD TRIMMER COMPONENTS(FOR LU-2266N-7) .....	15
左釜軸台糸切り関係 (LU-2266N-7用)	
9. RIGHT HOOK SHAFT BASE & HOOK COMPONENTS .....	17
右釜軸台・釜関係	
10. LEFT HOOK SHAFT BASE COMPONENTS(FOR LU-2266N-7) .....	19
左釜軸台関係 (LU-2266N-7用)	
11. THREAD TENSION COMPONENTS .....	21
糸調子関係	
12. LOWER THREAD WINDER MECHANISM COMPONENTS .....	23
下糸巻き装置関係	
13. PRESSURE ADJUSTING COMPONENTS .....	24
押え圧調節関係	
14. PRESSER LIFTER,AUTOMATIC PRESSER LIFTER & TENSION RELEASE MECHANISM COMPONENTS .....	25
押え上げ・自動押え上げ・糸ゆるめ機構関係	
15. LUBRICATION COMPONENTS .....	27
給油関係	
16. CONTROL DEVICE COMPONENTS .....	29
制御装置関係	
17. TABLE & BELT COVER COMPONENTS .....	31
テーブル・ベルトカバー関係	
18. THREAD STAND COMPONENTS .....	33
糸立て装置関係	
19. GAUGE COMPONENTS(LU-2216N-7 STANDARD PARTS) .....	34
ゲージ関係 (LU-2216N-7標準品)	

20. GAUGE COMPONENTS(LU-2266N-7 STANDARD PARTS) .....	35
ゲージ関係 (LU-2266N-7 標準品)	
21. ACCESSORIES PARTS COMPONENTS .....	36
付属品関係	
22. MUTUAL RISING QUANTITY TRANSFER COMPONENTS .....	37
交互上昇量切替装置関係	
23. BACK TUCK COMPONENTS .....	38
バックタック関係	
24. TABLE OF EXCHANGING GAUGE PARTS(LU-2266N-7) .....	39
交換ゲージ部品一覧表 (LU-2266N-7)	
25. TABLE OF EXCHANGING GAUGE PARTS(LU-2216N-7)(1) .....	41
交換ゲージ部品一覧表 (LU-2216N-7) (1)	
26. TABLE OF EXCHANGING GAUGE PARTS(LU-2216N-7)(2) .....	43
交換ゲージ部品一覧表 (LU-2216N-7) (2)	
NUMERICAL INDEX OF PARTS .....	45
索引	

# 1. FRAME & MISCELLANEOUS COVER COMPONENTS

頭部・外装関係

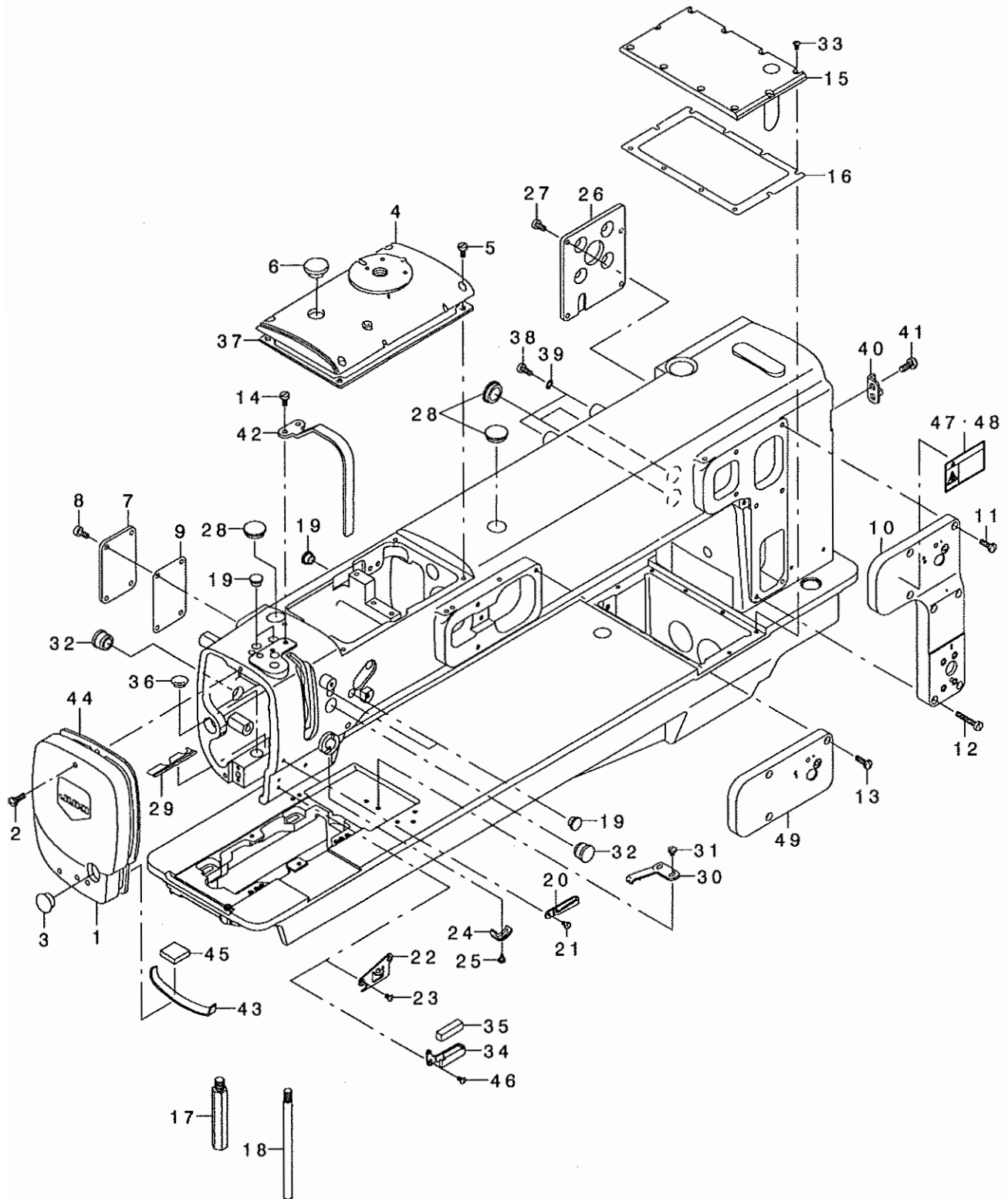

REF. NO	NOTE	PART NO.	DESCRIPTION	ヒョウメイ	Qty
1		107-43151	FACE PLATE ASM.	メンイタ クミ	1
2		SS-7121610-SP	SCREW 3/16-28 L=15.5	マルヒラネジ 3/16-28 L=15.5	2
3		TA-1250406-R0	RUBBER PLUG D=12.5 L=4	トメセン D=12.5 L=4	1
4		107-74651	TOP COVER ASM.	トップカバー-(クミ)	1
5		SS-6121010-SP	SCREW 3/16-28 L=10	ヒラネジ 3/16-28 L=10	4
6		TA-2050406-R0	RUBBER PLUG	トメセン	1
7		107-43003	SIDE COVER	ソクメンカバー-	1
8		SS-6121010-SP	SCREW 3/16-28 L=10	ヒラネジ 3/16-28 L=10	4
9		107-00706	SIDE COVER PACKING	ソクメンカバー-パッキン	1
10		107-42708	FACE APERTURE PLATE	シヨウメンマトイタ	1
11		SS-7121610-SP	SCREW 3/16-28 L=15.5	マルヒラネジ 3/16-28 L=15.5	3
12		SS-6123010-SP	SCREW 3/16-28 L=30.0	ヒラネジ 3/16-28 L=30	4
13		SS-7121610-SP	SCREW 3/16-28 L=15.5	マルヒラネジ 3/16-28 L=15.5	3
14		SS-6121010-SP	SCREW 3/16-28 L=10	ヒラネジ 3/16-28 L=10	2
15		231-51657	BET TOP COVER ASM.	ベツトップシヨウメンカバー-(クミ)	1
16		231-51707	TOP COVER PACKING	シヨウメンカバー-パッキン	1
17		107-01308	BED STRUT	ベツツトシチュウ	1
18		107-77308	BED STEW C	ベツツトシチュウC	1
19		TA-1050504-R0	RUBBER PLUG	トメセン	5
20		B1131-057-000	FRAME THREAD GUIDE, LOWER	イトアンナイシタ	1
21		SS-6090510-SP	SCREW 9/64-40 L=5	ヒラネジ 9/64-40 L=5	1
22		107-55700	ARM THREAD GUIDE D	アームイトアンナイD	1
23		SS-2090710-SP	SCREW 9/64-40 L=7	マルサラネジ 9/64-40 L=7	2
24		B3138-512-000	TAKE-UP SPRING ADJUSTING PLATE	イトトリカバー アンナイ チョーセツハン	1
25		SS-7090520-SP	SCREW 9/64-40 L= 4.5	マルヒラネジ 9/64-40 L=4.5	1
26		231-51400	APERTURE PLATE	マトイタ	1
27		SS-6121010-SP	SCREW 3/16-28 L=10	ヒラネジ 3/16-28 L=10	4
28		TA-2050406-R0	RUBBER PLUG	トメセン	3
29		107-31701	RUBBER	ゴホウウゴム	1
30		B1111-563-000	BED SLIDE SPRING	スベリイタパネ	1
31		SS-7110510-SP	SCREW 11/64-40 L=5	マルヒラネジ 11/64-40 L= 5	2
32		B1150-490-000	RUBBER PLUG	ウワオクリレンケツウデ キヤツブ	2
33		SS-7110910-TP	SCREW 11/64-40 L= 8.5	マルヒラネジ 11/64-40 L=8.5	10
34	#01	107-74008	FELT THREAD GUIDE	フェルトイトアンナイ	1
35	#01	226-03708	FELT	フェルト	1
36	#01	TA-1250504-R0	RUBBER PLUG	トメセン	1
37		107-00508	TOP COVER PACKING	トップカバー-パッキン	1
38		SS-6121210-SP	SCREW 3/16-28 L=12	ヒラネジ 3/16-28 L=12	2
39		WT-0530002-KS	TOOTHED WASHER D=5.3	ハツキサカネ D=5.3	2
40		107-45800	FLYWHEEL POINTER	ハズミグルマシシ	1
41		SS-7110510-SP	SCREW 11/64-40 L=5	マルヒラネジ 11/64-40 L= 5	2
42	#02	107-54901	THREAD TAKE-UP COVER	デンビシカハ-(JEシヨウ)	1
43		107-33103	FACE PLATE FELT	メンイタフェルト	1
44		107-04609	FACE PLATE PACKING	メンイタパッキン	1
45		B3510-019-000	OIL FELT	カンリユ-フェルト	1
46	#01	SS-2090710-SP	SCREW 9/64-40 L=7	マルサラネジ 9/64-40 L=7	1
47	#03	CM-3002001-01	SAFETY LABEL, 1(SMALL).	アンセシラハル 1(シヨウ)	1
48	#04	CM-3002001-A1	SAFETY LABEL, 3 (SMALL).	アンセシラハル 3(シヨウ)	1
49		231-51301	FACE APERTURE PLATE ,LEFT	ヒタリシヨウメンマトイタ	1
	NOTE (注記)		#01...FOR LU-2266N-7	LU-2266N-7用	
			#02...FOR JAPAN,JE	日本,JE用	
			#03...FOR JAPAN	日本用	
			#04...FOR EXPORT	輸出用	

2. MAIN SHAFT, HOOK DRIVING SHAFT DELIVERY  
& THREAD TAKE-UP LEVER COMPONENTS

上軸・下軸伝達装置・天秤関係

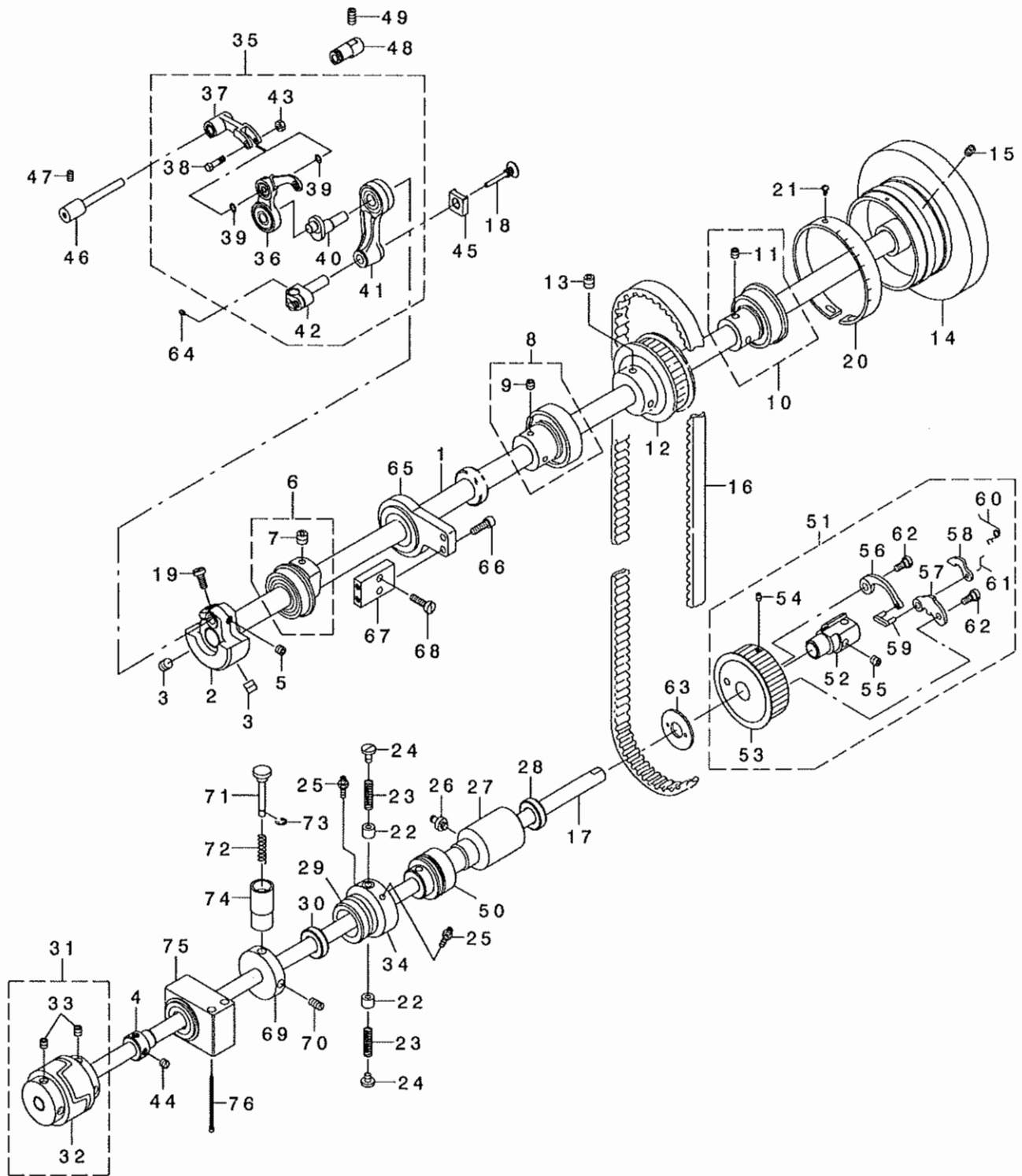

REF. NO	NOTE	PART NO.	DESCRIPTION	ヒョウメイ	Qty
1		231-53901	UPPER SHAFT	ウツシク	1
2		231-52903	BALANCE WEIGHT	ツリアイスイ	1
3		SM-8080812-TP	SCREW M8 L=8	トメネジ M8 L=8	2
4		231-54602	LOWER SHAFT BEARING HOLDER	シタシクハアリソクウケ	1
5		SS-8660512-TP	SCREW 1/4-40 L=5	トメネジ 1/4-40 L=5	1
6		107-04757	BALANCE WEIGHT	ハランスウエイト(クミ)	1
7		SM-8080802-TP	SCREW	トメネジ	(1)
8		107-04955	UPPER SHAFT BEARING HOOK A ASM	ウツシクハアリソクウケ(A)(クミ)	1
9		SM-8060602-TP	SCREW M6X6	トメネジ M6 L=6	(2)
10		107-04963	UPPER SHAFT BEARING HOOK B ASM	ウツシクハアリソクウケ(B)(クミ)	1
11		SM-8060602-TP	SCREW M6X6	トメネジ M6 L=6	(2)
12		107-05002	UPPER SPROCKET	ウエスフロケツト	1
13		SM-8080802-TP	SCREW	トメネジ	2
14		107-41007	FLYWHEEL, LARGE	ハズミクノルマ(タイ)	1
15		SS-8150822-TP	SCREW 15/64-28 L=8	トメネジ 15/64-28 L=8	2
16		107-06703	TIMING BELT	タイミンクハルト	1
17		231-54404	LOWER SHAFT	シタシク	1
18		107-08303	NEEDLE ROD THRUST SCREW	ハリネウカクコマズラストネジ	1
19		SS-6621220-SP	SCREW 3/16-32 L=12	ヒラネジ 3/16-32 L=12	1
20		107-45909	FLYWHEEL SCALE PLATE	ハズミクノルマメモリタ	1
21		SM-3030650-SC	SCREW M3X0.5 L=5	マシコネジ M3X0.5 L=5	3
22		110-20401	PLUNGER	プランジキ	2
23		110-20609	PLUNGER SPRING	プランジキハネ	2
24		110-20500	PLUNGER SCREW	プランジキネジ	2
25		SQ-1110401-MZ	CONNECTING SCREW	チユープレンカツネジ	2
26		SQ-1150451-MZ	CONNECTING SCREW	チユープレンカツネジ	1
27		107-75500	LOWER SHAFT REAR METAL	シモシクアトメタル	1
28		107-05606	LOWER SHAFT METAL OIL SEAL	シタシクアトメタルオイルシール	1
29		107-05754	LOWER SHAFT FRONT METAL ASM.	シモシククマエメタル(クミ)	1
30		107-05606	LOWER SHAFT METAL OIL SEAL	シタシクアトメタルオイルシール	1
31		107-76664	LOWER SHAFT COUPLING SET	シモシクカクアアリソク(セツト)	1
32		107-76666	LOWER SHAFT COUPLING ASM.	シモシクカクアアリソク(クミ)	(1)
33		SM-8060602-TP	SCREW M6X6	トメネジ M6 L=6	(4)
34		RO-2943101-00	RUBBER RING	Oリング	1
35		231-52754	BALANCE ASM.	テンビン(クミ)	1
36		107-71251	BALANCE JUNCTION COMPL.	テンビン(クマゴウ)	(1)
37		107-07156	BALANCE CRANK JUNCTION	テンビンクランククマゴウ	(1)
38		107-54802	BALANCE CRANK PIN.	テンビンクランクピン	(1)
39		105-23702	WASHER	テンビンクランクワッシャ	(2)
40		231-52705	NEEDLE ROD CRANK	ハリネウクランク	(1)
41		231-52853	NEEDLE ROD CRANK ROD ASM.	ハリネウクランクロッド(クミ)	(1)
42		107-07958	NEEDLE ROD HOLDER ASM.	ハリネウタキクミ	(1)
43		NM-6040001-SN	NUT M4X0.7	6カクナツト M4	(1)
44		SS-8150510-TP	SCREW 15/64-28 L= 4.7	トメネジ 15/64-28 L=4.7	2
45		231-53307	NEEDLE ROD SQUARE BLOCK	ハリネウカクゴヤ	1
46		107-07206	BALANCE CRANK SHAFT	テンビンクランクシャフト	1
47		SS-8120740-SP	SCREW 3/16-28 L=7	トメネジ 3/16-28 L=7	1
48		107-07305	BALANCE CRANK SHAFT SUPPORT	テンビンクランクシャフトササエ	1
49		SM-8061212-TP	SCREW M6X12	トメネジ M6 L=12	1
50		RO-3122401-00	O-RING	Oリング	1
51		107-75658	SAFETY DEVICE ASM.	アンセツウチエ(クミ)	1
52		107-75609	SAFETY DEVICE HOOK	アンセツウチエフック	(1)
53		107-06315	LOWER SPROCKET	シタスフロケツト	(1)
54		SM-8040502-TP	SCREW M4X0.7 L=5	トメネジ M4X0.7 L=5	(1)
55		SM-8060602-TP	SCREW M6X6	トメネジ M6 L=6	(2)
56		105-91709	SAFETY SPRING	アンセツウチエハネ	(1)
57		107-48002	SAFETY CLUTCH PAWL	アンセツウチエメ	(1)
58		B1308-055-000	SAFETY CLUTCH COUNTER-HOOK	アンセツウチエキキクツメ	(1)
59		B1310-055-000	SAFETY CLUTCH SMALL LINK	アンセツウチエショウリンク	(1)
60		B1309-055-000	COUNTER-HOOK SPRING	アンセツウチエキキクツメハネ	(1)
61		B1314-055-000	SAFETY CLUTCH SMALL LINK PIN	アンセツウチエショウリンクピン	(1)
62		SD-0640322-TP	HINGE SCREW D= 6.35 H= 3.2	ダシネジ D=6.35 H=3.2	(2)
63		107-06802	LOWER SHAFT COUPLING PLATE	シタシクカクアアリソクスラストイタ	1
64		SM-8030402-TP	SCREW M3X0.5 L=4	トメネジ	1
65		231-54057	BEARING ASM.	ハアリソクサ(クミ)	1
66		SM-6051602-TP	SCREW M5X0.8 L=16	ロツカクアチネルト M5X0.8 L=16	2
67		231-54107	BEARING BASIS	ハアリソクサトタイ	1
68		SS-6121860-SP	SCREW 3/16-28 L=18	ヒラネジ 3/16-28 L=18	2
69		231-54701	SAFETY CLUTCH DISK	アンセツウチエソコ	1
70		SS-8151150-TP	SCREW 15/64-28 L=10.5	トメネジ 15/64-28 L=10.5	2
71		B1636-158-000	PUSH BUTTON	オクリチヨセツオシホタツ	1
72		B1639-158-000	PUSH BUTTON SPRING	オクリチヨセツオシホタツハネ	1
73		RE-0400000-KO	E-RING 4	Eホタツメ 4	1
74		231-54800	SAFETY CLUTCH PUSH BUTTON BUSH	アンセツウチエオシホタツフツシユ	1
75		231-54552	FRONT METAL HOLDER A	シタシククマエメタルウケ(クミ)	1
76		SM-6065002-TP	SCREW M6 L=50	ロツカクアチネルト M6 L=50	2

### 3. NEEDLE BAR ROCKING COMPONENTS

針棒搖動關係

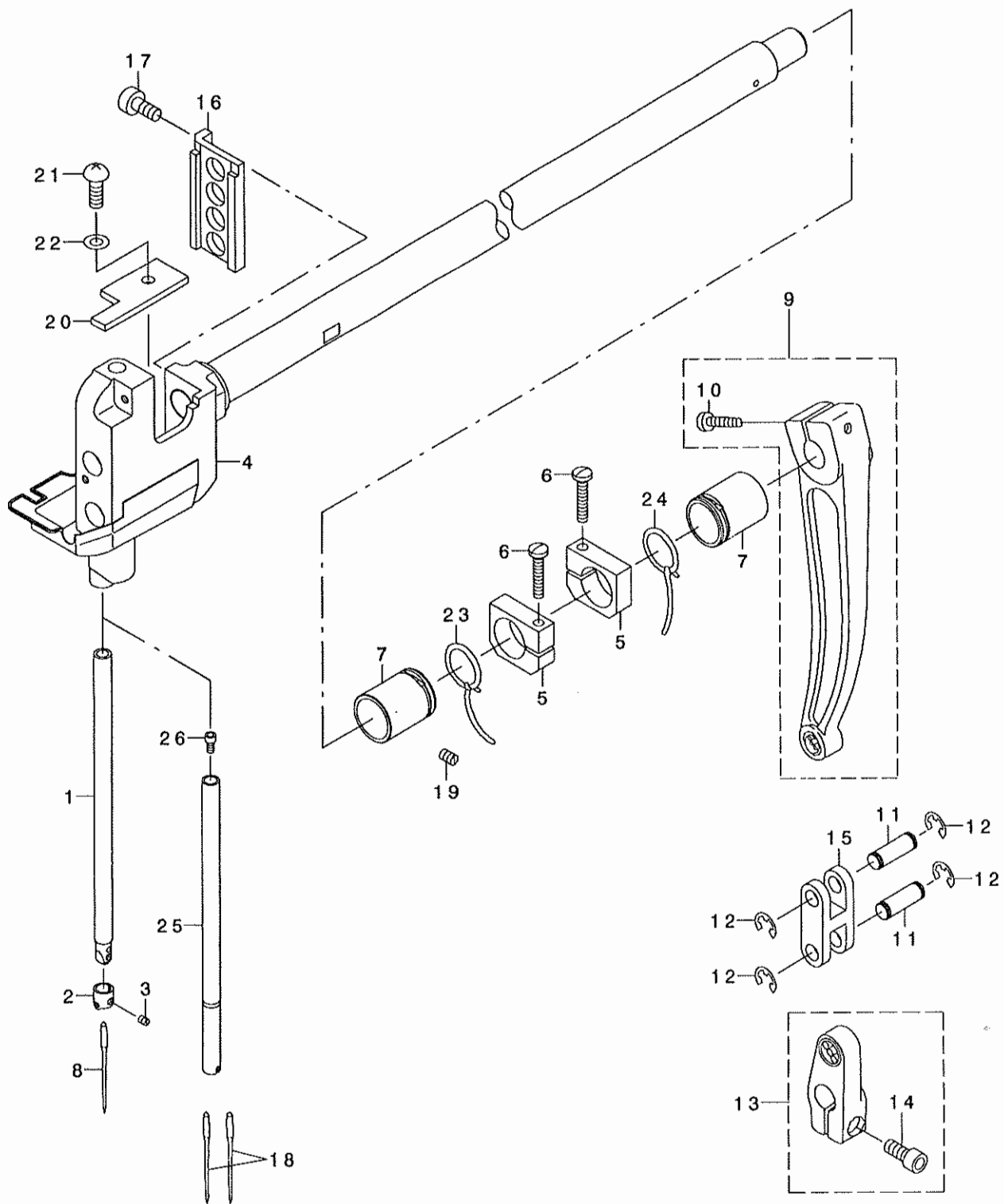



REF. NO	NOTE	PART NO.	DESCRIPTION	ヒョウメイ	Qty
1		231-53505	NEEDLE BAR	ハリホウウ	1
2		107-08204	NEEDLE BAR THREAD GUIDE	ハリホウウイトカク	1
3		SS-8080410-TP	SCREW 1/8-44 L=3.5	トメネジ 1/8-44 L=3.5	1
4		231-52663	NEEDLE ROD ROCKING BASE SET	ハリホウウヨウトウタ イ(セツ)	1
5		231-53208	THRUST HOLDER	スラストウケ	2
6		SS-7112420-SP	SCREW 11/64-40 L=24	マルヒラネジ 11/64-40 L=24	2
7		231-53109	FRONT METAL	ハリホウウヨウトウウシクマエメタル	2
8		MC-3210014-00	NEEDLE 134-35 #140	ハリ 134-35 #140	1
9		107-09152	NEEDLE ROD ROCKING LINK ASM.	ハリホウウヨウトウウカン(クミ)	1
10		SS-6152440-SP	SCREW 15/64-28 L=23.5	ヒラネジ 15/64-28 L=23.5	(1)
11		107-09202	NEEDLE ROD LINK PIN	ハリホウウヨウトウウリンクピン	2
12		RE-0600000-K0	E-RING 6	Eカ タトメワ 6	4
13		107-09350	FEED ARM ASM.	ハリオクリウテ (クミ)	1
14		SS-6151412-TP	SCREW 15/64-28 L=14	ロツカクアナホ ルト 15/64-28	(1)
15		107-09400	NEEDLE ROD ROCKING LINK	ハリホウウヨウトウウリンク	1
16		107-08501	ROLLER GUIDE BASE	コロアンナイタ イ	1
17		SM-6041012-TP	SCREW M4X0.7 L=10	ヒラコネジ M4X0.7 L=10	2
18	#01	MC-3210014-00	NEEDLE 134-35 #140	ハリ 134-35 #140	2
19		SS-8120740-SP	SCREW 3/16-28 L=7	トメネジ 3/16-28 L=7	1
20		107-33806	SWING STAND FELT, LOWER	ヨウトウタ イフェルト(シタ)	1
21		SM-1040801-SC	SCREW M4X0.7 L=8	サラコネジ M4X0.7 L=8	1
22		WP-0450000-SD	WASHER 4.5X8X0.5	ヒラサカネ 4.5X8X0.5	1
23		CQ-2020000-00	OIL WICK	ユシソ	0.2
24		CQ-2020000-00	OIL WICK	ユシソ	0.2
25	#01	231-53406	NEEDLE BAR (FOR 2-NEEDLE)	ハリホウウ(2ホソハリヨウ)	1
26	#01	SM-6030602-TP	SCREW M3X0.5 L=6	ロツカクアナホ ルト M3X0.5 L=6	1

NOTE (注記) #01...FOR LU-2266N-7 LU-2266N-7用

# 4. UPPER FEED MECHANISM COMPONENTS

上送り関係

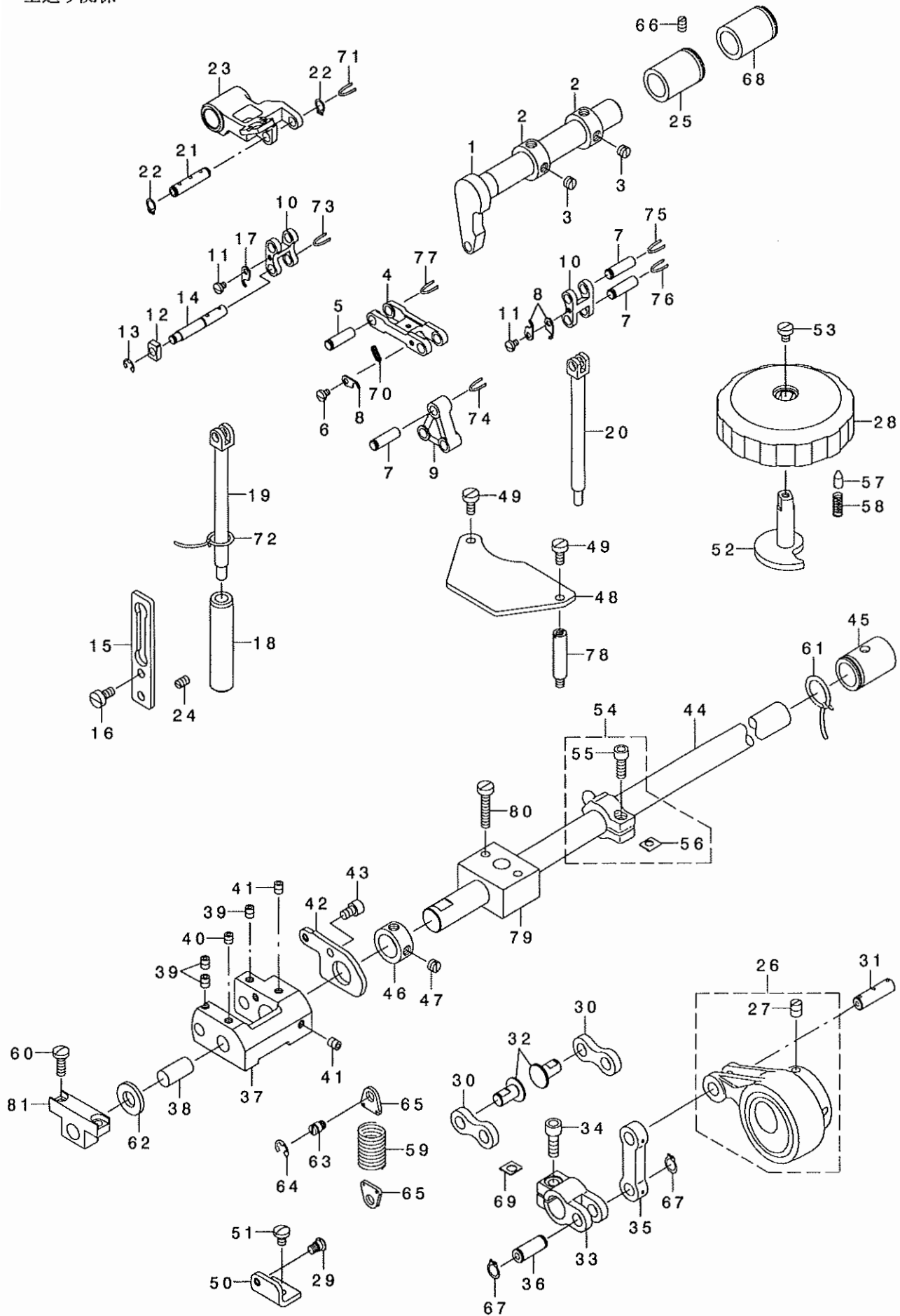

REF. NO	NOTE	PART NO.	DESCRIPTION	キ ャ ム イ	Qty
1		107-09707	UPPER FEED SHAFT	ウツネクリツク	1
2		CS-1501011-TH	THRUST COLLAR	スラストウケ	2
3		SS-8660410-SP	SCREW 1/4-40 L= 4.2	トメネジ 1/4-40 L=4.2	4
4		107-09806	CONNECTION LINK	レンクツリツク	1
5		107-09905	TRIANGLE LEVER SHAFT	チンカテコソク	1
6		SS-7080510-TP	SCREW 1/8-44 L=4.5	マムヒラネジ 1/8-44 L=4.5	1
7		107-09905	TRIANGLE LEVER SHAFT	チンカテコソク	3
8		107-10804	TRIANGLE LEVER SHAFT STOPPER	チンカテコソク トメ	3
9		107-10002	TRIANGLE LEVER	チンカテコ	1
10		107-10101	ROCKING LINK	ヨウトウリンク	2
11		SS-7080510-TP	SCREW 1/8-44 L=4.5	マムヒラネジ 1/8-44 L=4.5	2
12		107-10200	PRESSER ROD SQUARE BLOCK	オチエネ ウカ イト カクコ マ	1
13		RE-0400000-KO	E-RING 4	Eカ タトメ 4	1
14		107-10309	PRESSER ROD GUIDE SHAFT	オチエネ ウカ イト シク	1
15		107-10408	PRESSER ROD GUIDE	オチエネ ウカ イト	1
16		SS-6121050-SP	SCREW 3/16-28 L= 9.5	ヒラネジ 3/16-28 L=9.5	2
17		107-10804	TRIANGLE LEVER SHAFT STOPPER	チンカテコソク トメ	1
18		107-10507	PRESSER ROD LOWER METAL	オチエネ ウツタメタル	1
19		107-10606	PRESSER ROD	オチエネ ウ	1
20		107-10705	UPPER FEED ROD	ウツネクリツク ウ	1
21		107-11000	PRESSER ROD SHAFT	オチエネ ウツク	1
22		RC-0560711-KP	RETAINING RING	Cカ タトメ 4	2
23		107-11117	PRESSER BAR GUIDE ARM	オチエネ ウカ イト ウツ	1
24		SS-8120740-SP	SCREW 3/16-28 L=7	トメネジ 3/16-28 L=7	1
25		107-09608	ROCKING SHAFT METAL	ウツネクリツク クラメタル	1
26		107-13766	ECCENTRIC ROD (SET)	ウツネクリツク アロツト (セツ)	1
27		SS-8660810-TP	SCREW 1/4-40 L=8	トメネジ 1/4-40 L=8	(2)
28		107-74305	VERTICAL DIAL	コウゴ シ ヨウケ タ イタル	1
29		110-07101	HINGE SCREW	ヒヂ アケ ヨコネ ウツネ	1
30		107-14509	CONNECTION LINK B	レンクツリツク B	2
31		107-13808	CONNECTION LINK PIN B	レンクツリツク B ピン	1
32		107-14608	CONNECTION LINK B SUPPORT PIN	レンクツリツク B サポート ピン	2
33		107-13907	UPPER FEED CAM	ウツネクリツク	1
34		SM-6061602-TP	SCREW M6 L=16	ロツカアツネ タ	1
35		107-14004	CONNECTION LINK A	レンクツリツク A	1
36		107-14103	CONNECTION LINK PIN A	レンクツリツク A ピン	1
37		107-14202	VERTICAL CHANGE BELT	コウゴ シ ヨウケ アンカンタイ	1
38		107-51303	CHANGE BELT SUPPORT PIN	コウゴ シ ヨウケ アンカンタイ サポート ピン	1
39		SM-8050602-TP	SCREW M5 L=6	トメネジ M5X0.8 L=6	3
40		SM-8050502-TP	SCREW M5 L=5	トメネジ	1
41		SM-8050602-TP	SCREW M5 L=6	トメネジ M5X0.8 L=6	2
42		107-14400	VERTICAL STOPPER PLATE	コウゴ シ ヨウケ ストップ - イタ	1
43		SM-6050802-TP	SCREW M5X0.8 L=8	ロツカアツネ タ M5X0.7 L=8	1
44		231-56102	VERTICAL CHANGE BELT SHAFT	コウゴ シ ヨウケ アンカンタイ	1
45		231-56203	HORIZONTAL SHAFT METAL	スイヘイ クメタル	1
46		CS-1501011-TH	THRUST COLLAR	スラストウケ	1
47		SS-8660410-SP	SCREW 1/4-40 L= 4.2	トメネジ 1/4-40 L=4.2	2
48		231-56508	VERTICAL STOPPER HOLD PLATE	コウゴ シ ヨウケ ストップ - ウケイタ	1
49		SS-6121010-SP	SCREW 3/16-28 L=10	ヒラネジ 3/16-28 L=10	2
50		107-14905	VERTICAL SHAFT SPRING RACK	コウゴ シ ヨウケ シ クハ ネカク	1
51		SS-7120710-SP	SCREW 3/16-28 L=7	マムヒラネジ 3/16-28 L=7	1
52		107-15001	VERTICAL ADJUSTING CAM	コウゴ シ ヨウケ チヨウビツカ	1
53		SS-6110630-TP	SCREW 11/64-40 L=6	ヒラネジ 11/64-40 L=6	1
54		107-15258	VERTICAL ADJUSTING ARM ASM.	コウゴ シ ヨウケ チヨウビツウツ (クミ)	1
55		SM-6051402-TP	SCREW M5X0.8 L=14	ロツカアツネ タ	(1)
56		107-11406	SPACER B	スパ - B	(1)
57		107-15704	VERTICAL DIAL PIN	コウゴ シ ヨウケ タ イタル ピン	1
58		B1526-527-00G	SPRING	オチエネ ハネ	1
59		107-16504	VERTICAL SHAFT SPRING	コウゴ シ ヨウケ シ クハ ネ	1
60		SS-7121410-TP	SCREW 3/16-28 L=14	マムヒラネジ 3/16-28 L=14	2
61		CQ-2020000-00	OIL WICK	ユツ	0.3
62		101-09809	THRUST WASHER, B	カマシ クツリツク スラストイタ B	1
63		B3416-552-000	CONNECTING ROD HINGE SCREW	ヒヂ アケ ヨコネ - タツネジ	1
64		RE-0500000-KO	E-RING	Eカ タトメ 5	1
65		107-13501	SPRING HOOK	コウゴ シ ヨウケ シ クハ ネカク	2
66		SS-8120740-SP	SCREW 3/16-28 L=7	トメネジ 3/16-28 L=7	1
67		RC-0740811-KP	C-RING	Cカ タトメ 8	2
68		107-08907	ROCKING SHAFT METAL	ヨウトウリンク クメタル	1
69		107-10903	SPACER A	スパ - A	1
70		107-39506	GUIDE SPRING	ウツネクリツク ユウコカ イト ハネ	1
71		CQ-2520000-00	OIL WICK	ユツ	0.1
72		CQ-2020000-00	OIL WICK	ユツ	0.2
73		CQ-2520000-00	OIL WICK	ユツ	0.1
74		CQ-2520000-00	OIL WICK	ユツ	0.1
75		CQ-2520000-00	OIL WICK	ユツ	0.1
76		CQ-2520000-00	OIL WICK	ユツ	0.1
77		CQ-2520000-00	OIL WICK	ユツ	0.1
78		231-56300	STUD	スタット	1
79		231-56201	VERTICAL METAL	コウゴ シ ヨウケ メタル	1
80		SS-6122510-SP	SCREW 3/16-28 L=25	ヒラネジ 3/16-28 L=25	2
81		231-56409	CHANGE SUPPORT	アンカンタイササ	1

5. FEED ADJUSTMENT & REVERSE FEED MECHANISM COMPONENTS

送り調節・逆送り関係

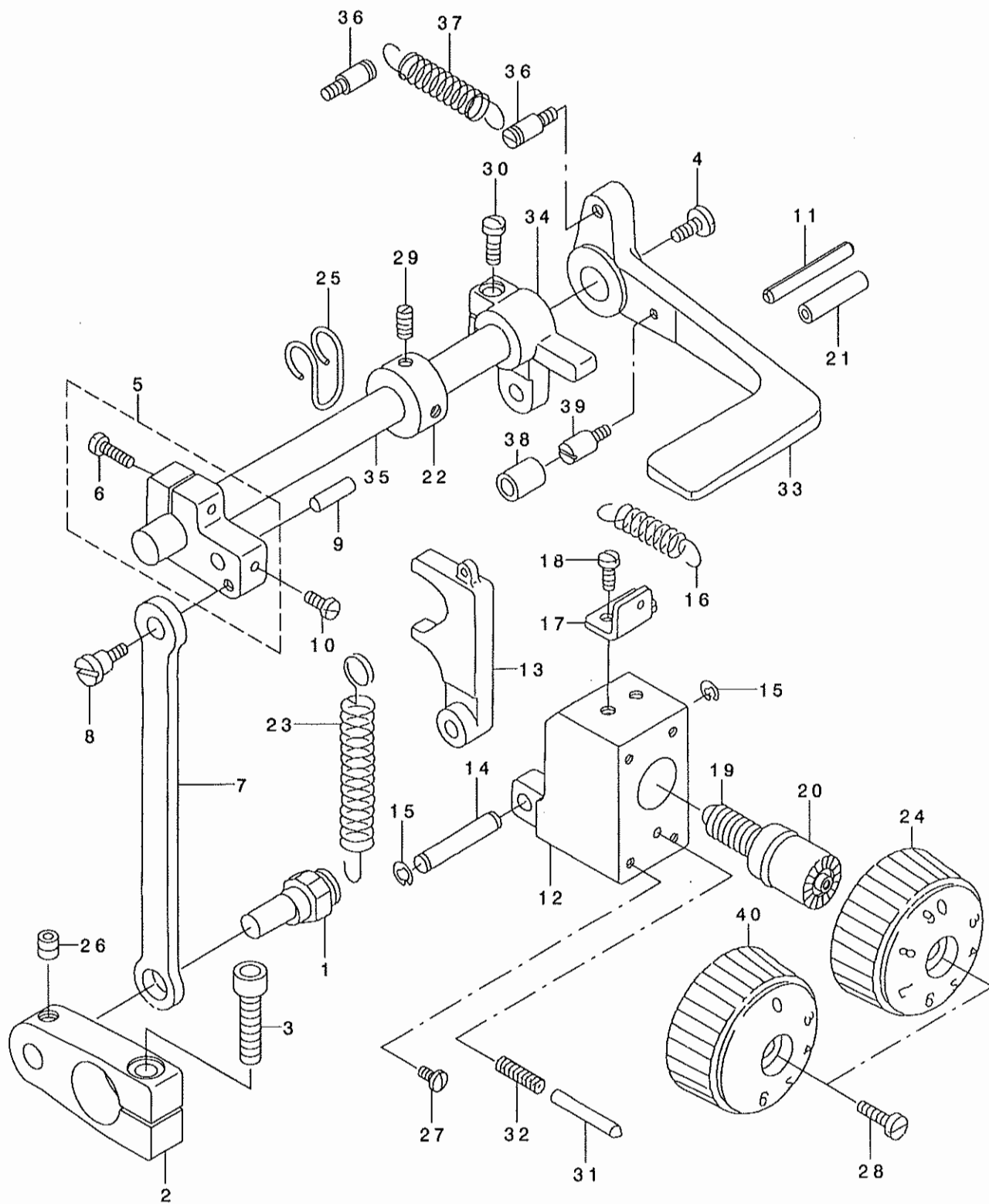

REF. NO.	NOTE	PART NO.	DESCRIPTION	と ン メ イ	Qty
1		107-20209	ADJUSTING CHANGE PIN	オクリチヨウセツハンシンビ <sup>ン</sup>	1
2		231-55500	ADJUSTING CHANGE ARM	オクリチヨウセツハンカンウテ <sup>ノ</sup>	1
3		SM-6062502-TP	SCREW M6 L=25	ロツカクアナホ <sup>ノ</sup> ルト M6 L=25	1
4		SS-7620750-SP	SCREW 3/16-32 L= 6.5	マルヒラネシ <sup>ノ</sup> 3/16-32 L=6.5	1
5		107-20555	ADJUSTING ARM ASM.	オクリチヨウセツウテ <sup>ノ</sup> (クミ)	1
6		SS-7121610-SP	SCREW 3/16-28 L=15.5	マルヒラネシ <sup>ノ</sup> 3/16-28 L=15.5	(1)
7		107-20407	ADJUSTING CONNECTION RING	オクリチヨウセツレンケツカン	1
8		107-25307	ADJUSTING CONNECTION RING PIN	オクリチヨウセツレンケツカンビ <sup>ン</sup>	1
9		107-21504	FEED ADJUSTING PIN	オクリチヨウセツビ <sup>ン</sup>	1
10		SS-7110810-SP	SCREW 11/64-40 L= 8.0	マルヒラネシ <sup>ノ</sup> 11/64-40 L=8	1
11		PS-0400322-KP	SPRING PIN 4.OX32	スプリング <sup>ノ</sup> ビ <sup>ン</sup> 4.OX32	1
12		107-20704	ADJUSTING BASE	オクリチヨウセツタ <sup>ノ</sup> イ	1
13		107-20605	ADJUSTING BELT	オクリチヨウセツタイ	1
14		107-20803	REGULATION STAND FULCRUM AXIS	オクリチヨウセツタイシデンシ <sup>ノ</sup> ク	1
15		RE-0400000-K0	E-RING 4	Eカ <sup>ノ</sup> タメワ 4	2
16		107-21306	CHANGE SPRING	チヨウセツタイハンカンハ <sup>ノ</sup> ネ	1
17		107-21702	ADJUSTING SPRING RACK	オクリチヨウセツハ <sup>ノ</sup> ネカケ	1
18		SS-7110710-SP	SCREW 11/64-40 L=7	マルヒラネシ <sup>ノ</sup> 11/64-40 L=7	2
19		107-21009	ADJUSTING DIAL SCREW	オクリチヨウセツタ <sup>ノ</sup> イヤルネシ <sup>ノ</sup>	1
20		RO-1182401-00	O-RING	Oリング <sup>ノ</sup>	1
21		BT-0600402-EA	OIL TUBE	チューブ <sup>ノ</sup>	0.1
22		CS-1201011-SH	THRUST COLLAR D=12 W=10	スラストウケ D=12 W=10	1
23		107-22007	PULLING SPRING	オクリチヨウセツタイヒツハ <sup>ノ</sup> リハ <sup>ノ</sup> ネ	1
24		107-44308	ADJUSTMENT DIAL	オクリチヨウセツタ <sup>ノ</sup> イヤル	1
25		107-33509	SPRING RACK HOOK	ヒツハ <sup>ノ</sup> リハ <sup>ノ</sup> ネカケフック	1
26		SM-8060602-TP	SCREW M6X6	トメネシ <sup>ノ</sup> M6 L=6	1
27		SS-7110910-SP	SCREW 11/64-40 L=8.5	マルヒラネシ <sup>ノ</sup> 11/64-40 L=8.5	4
28		SS-6121860-SP	SCREW 3/16-28 L=18	ヒラネシ <sup>ノ</sup> 3/16-28 L=18	1
29		SS-8660610-TP	SCREW 1/4-40 L=6	トメネシ <sup>ノ</sup> 1/4-40 L=6	2
30		SS-7121610-SP	SCREW 3/16-28 L=15.5	マルヒラネシ <sup>ノ</sup> 3/16-28 L=15.5	1
31		107-18401	DIAL PIN	オクリタ <sup>ノ</sup> イヤルビ <sup>ン</sup>	1
32		B1148-141-H00	SPRING	オクリ チヨウセツ ビ <sup>ン</sup> ハ <sup>ノ</sup> ネ	1
33		107-43805	BACKWARD STITCH LEVER	キ <sup>ノ</sup> ヤクオクリレハ <sup>ノ</sup> -	1
34		107-21207	BACKWARD FEED CONNECTION ARM	キ <sup>ノ</sup> ヤクオクリレンケツウテ <sup>ノ</sup>	1
35		231-55401	BACKWARD FEED LEVER SHAFT	キ <sup>ノ</sup> ヤクオクリレハ <sup>ノ</sup> -シ <sup>ノ</sup> ク	1
36		101-20004	SPRING SUSPENSION	キ <sup>ノ</sup> ヤクオクリレハ <sup>ノ</sup> - ハ <sup>ノ</sup> ネカケ	2
37		D2515-232-D00	TORSION SPRING	イタカム ヒツハ <sup>ノ</sup> リイタ カエシハ <sup>ノ</sup> ネ	1
38		101-19907	CUSHION	キ <sup>ノ</sup> ヤクオクリレハ <sup>ノ</sup> - コ <sup>ノ</sup> ムワ	1
39		B1114-280-000	PIN	ビ <sup>ン</sup>	1
40	#01	231-55955	ADJUSTMENT DIAL ASM.	オクリチヨウセツタ <sup>ノ</sup> イヤル (クミ)	1

NOTE (注記)

#01...FOR LU-2266N-7

LU-2266N-7用

# 6. LOWER FEED MECHANISM COMPONENTS

下送り関係

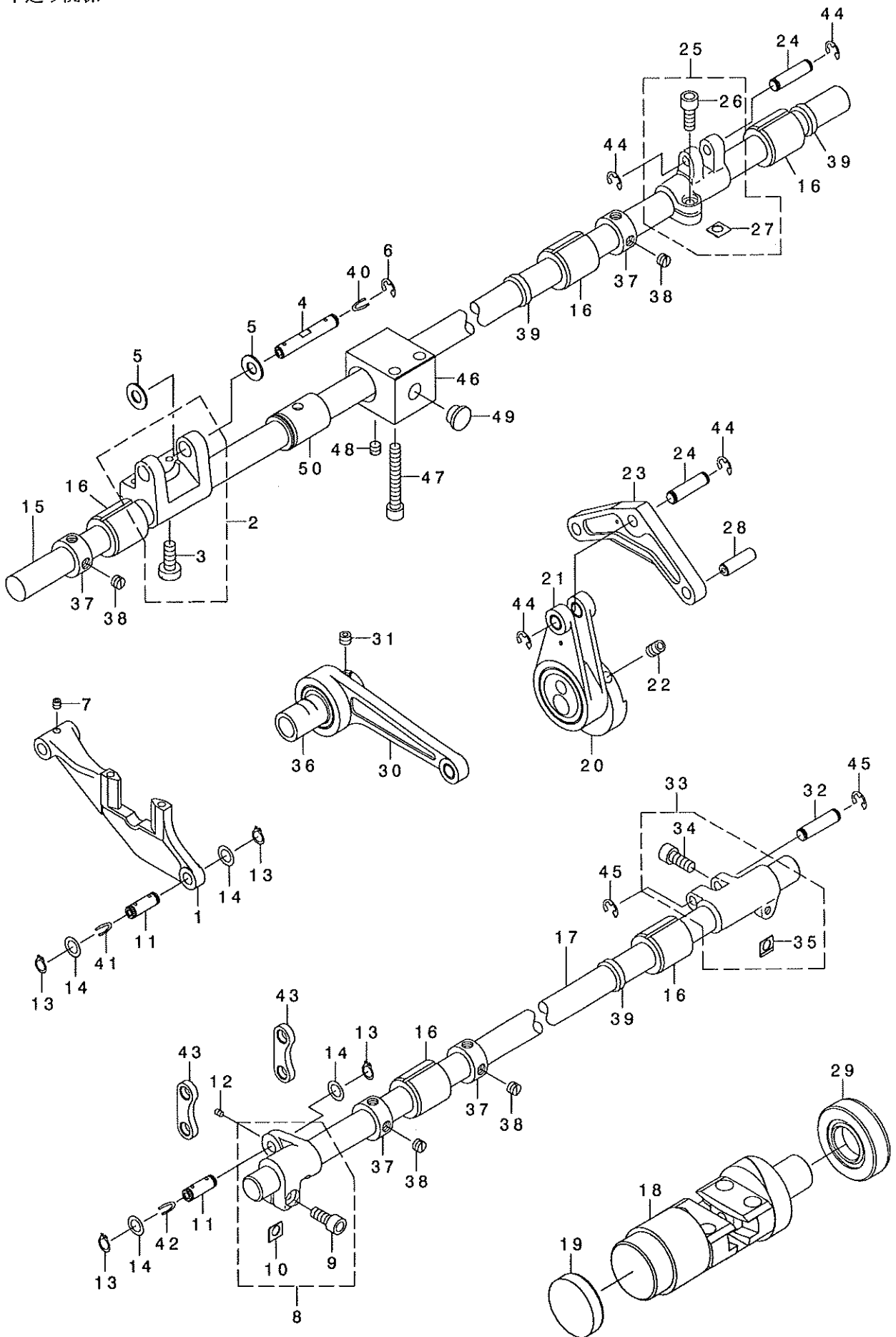

REF. NO	NOTE	PART NO.	DESCRIPTION	ヒョウメイ	Qty
1		107-17502	FEED BASE	オクリタ' イ	1
2		107-17668	FEED BASE ARM ASM.	スイハイオクリタ' イウテ' (セツト)	1
3		SM-6061650-TP	SCREW	ヒラネジ' M6 L=16	(2)
4		107-17809	FEED BASE SHAFT	スイハイオクリタ' イジ' ク	1
5		107-46709	WASHER	オクリタ' イスラストサ' カ' ネ	2
6		RE-0500000-KO	E-RING	Eカ' タトメワ 5	1
7		SS-8110422-TP	SCREW 11/64-40 L=4	トメネジ' 11/64-40 L=4	1
8		107-18658	VERTICAL FEED ARM ASM.	ジ' ヨウケ' オクリウテ' (クミ)	1
9		SS-6151412-TP	SCREW 15/64-28 L=14	ロツカクアナホ' ルト 15/64-28	(1)
10		107-10903	SPACER A	スハ' -サA	(1)
11		107-18906	VERTICAL FEED LINK SHAFT	ジ' ヨウケ' オクリリンクジ' ク	2
12		SM-8030402-TP	SCREW M3X0.5 L=4	トメネジ'	1
13		RC-0650811-KP	RETAINING RING	Cカ' タトメワ	4
14		WP-0740516-SP	WASHER 7.4X11.8X0.5	ヒラサ' カ' ネ 7.4X11.8X0.5	4
15		231-55005	HORIZONTAL FEED SHAFT	スイハイオクリジ' ク	1
16		107-18203	FEED SHAFT FRONT METAL	スイハイオクリジ' クマエメタル	5
17		231-55708	VERTICAL FEED SHAFT	ジ' ヨウケ' オクリジ' ク	1
18		107-19052	FEED CHANGE BELT ASM.	オクリハンカンタイ クミ	1
19		107-19706	CHANGE BELT OIL SEAL A	ハンカンタイオイルシールA	1
20		107-19219	HORIZONTAL FEED CAM	スイハイオクリカム	1
21		107-19672	HORIZONTAL FEED ROD ASM.	スイハイオクリロツト' (クミ)	1
22		SS-8661012-TP	SCREW	トメネジ'	2
23		107-19300	BELL CRANK	ハ' ルクランク	1
24		107-18005	FEED ARM SHAFT	オクリウテ' ジ' ク	2
25		107-18153	FEED SHAFT ARM ASM.	オクリジ' クウテ' (クミ)	1
26		SM-6061552-TP	SCREW M6 L=15	ロツカクアナホ' ルト	(1)
27		107-10903	SPACER A	スハ' -サA	(1)
28		107-19508	ADJUSTING BLOCK SHAFT	オクリチヨウセツカクコ' マジ' ク	1
29		107-19805	CHANGE BELT OIL SEAL B	ハンカンタイオイルシールB	1
30		107-19979	VERTICAL FEED ROD ASM.	ジ' ヨウケ' オクリロツト' (クミ)	1
31		SM-8060552-TP	SCREW M6 L=5	トメネジ'	2
32		107-18005	FEED ARM SHAFT	オクリウテ' ジ' ク	1
33		107-18153	FEED SHAFT ARM ASM.	オクリジ' クウテ' (クミ)	1
34		SM-6061552-TP	SCREW M6 L=15	ロツカクアナホ' ルト	(1)
35		107-10903	SPACER A	スハ' -サA	(1)
36		107-20019	VERTICAL FEED CAM	ジ' ヨウケ' オクリカム	1
37		CS-1501011-TH	THRUST COLLAR	スラストウケ	4
38		SS-8660410-SP	SCREW 1/4-40 L= 4.2	トメネジ' 1/4-40 L=4.2	8
39		137-07500	OIL SEAL	ウツジ' ク マエメタル オイルシール	3
40		CQ-2020000-00	OIL WICK	ユツン	0.1
41		CQ-2020000-00	OIL WICK	ユツン	0.1
42		CQ-2020000-00	OIL WICK	ユツン	0.1
43		107-18500	VERTICAL LINK	オクリタ' イジ' ヨウケ' リンク	2
44		RE-0500000-KO	E-RING	Eカ' タトメワ 5	4
45		RE-0500000-KO	E-RING	Eカ' タトメワ 5	2
46		231-55104	HORIZONTAL SHAFT INNER METAL	スイハイジ' クナカメタル	1
47		SM-6064002-TP	SCREW M6 L=40	ロツカクアナホ' ルト M6 L=40	2
48		SS-8150510-TP	SCREW 15/64-28 L= 4.7	トメネジ' 15/64-28 L=4.7	1
49		TA-1050504-RO	RUBBER PLUG	トメセン	1
50		231-55203	HORIZONTAL SHAFT METAL	スイハイジ' クメタル	1

# 7. RIGHT HOOK SHAFT BASE THREAD TRIMMER COMPONENTS

右釜軸台系切り関係

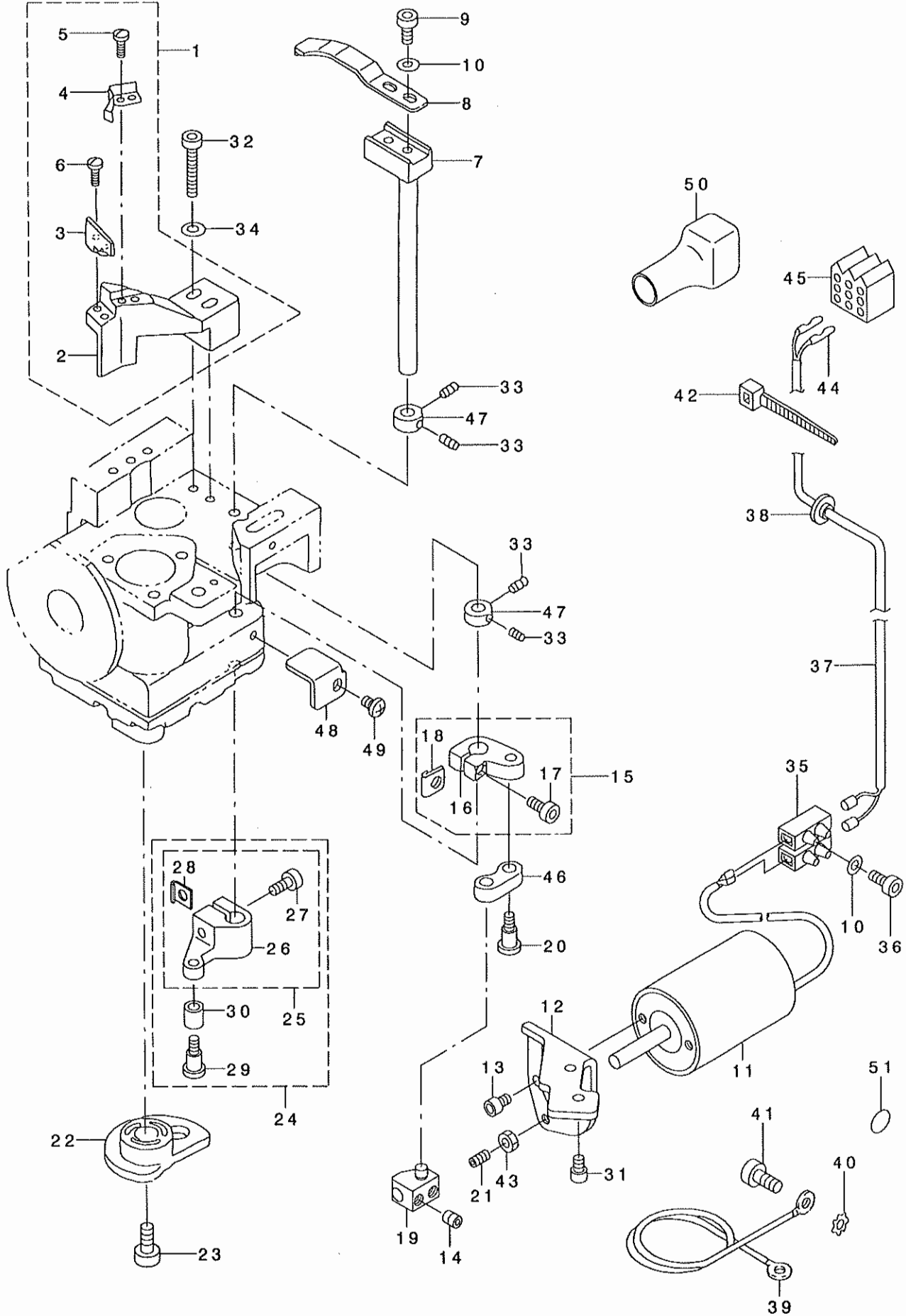



REF. NO	NOTE	PART NO.	DESCRIPTION	ヒソメイ	Qty
1		107-26552	FIXED KNIFE BASE ASM.	コテメスタ'イクミ	1
2		107-26503	FIXED KNIFE BASE	コテメスタ'イ	(1)
3		107-26404	FIXED KNIFE	コテメス	(1)
4		107-26909	CLAMP SPRING	クランプ'ハ'ネ	(1)
5		SS-7060610-SP	SCREW 3/32-56 L= 5.5	マルヒラネシ' 3/32-56 L=5.5	(2)
6		SS-7060610-SP	SCREW 3/32-56 L= 5.5	マルヒラネシ' 3/32-56 L=5.5	(2)
7		107-26800	MOVING KNIFE SHAFT	ト'ウメスシ'ク	1
8		107-26305	MOVING KNIFE	ト'ウメス	1
9		SM-6030802-TP	SCREW M3X0.5 L=8	ロツカクアナホ'ルト M3X0.5 L=8	2
10		WP-0320501-SC	WASHER M3	ヒラサ'カ'ネ 3.2X7X0.5	3
11		107-72804	THREAD CUTTING SOLENOID	イトキリソレノイト'	1
12		107-72309	SOLENOID FITTING PLATE,RIGHT	イトキリソレノイト'トリツケイタ(ミキ')	1
13		SM-6040602-TP	SCREW M4 L=6	ロツカクアナホ'ルト M4X0.7 L=6	2
14		SM-8050602-TP	SCREW M5 L=6	トメネシ' M5X0.8 L=6	2
15		107-27857	DRIVING ARM B ASM.	ト'ウメスクト'ウウテ' B(クミ)	1
16		107-27808	DRIVING ARM B	ト'ウメスクト'ウウテ' B	(1)
17		SM-6041202-TP	SCREW M4X0.7 L=12	ロツカクアナホ'ルト	(1)
18		107-11505	SPACER C	スパ'ーサC	(1)
19		107-54505	THREAD CUTTING SOLENOID ARM	イトキリソレノイト'ウテ'	1
20		SD-0500481-TP	HINGE SCREW D= 5 H= 4.8	タ'ンネシ' D=5 H=4.8	1
21		SM-8040802-TP	SCREW M4X8	トメネシ' M4X0.7 L=8	1
22		107-27709	THREAD CUTTING CAM	イトキリカム	1
23		SM-6041202-TP	SCREW M4X0.7 L=12	ロツカクアナホ'ルト	3
24		107-28160	DRIVING ARM A COMPL.	ト'ウメスクト'ウウテ' A(ケツコ'ウ)	1
25		107-28152	DRIVING ARM A ASM.	ト'ウメスクト'ウウテ' A(クミ)	(1)
26		107-28103	DRIVING ARM A	ト'ウメスクト'ウウテ' A	(1)
27		SM-6051402-TP	SCREW M5X0.8 L=14	ロツカクアナホ'ルト	(1)
28		107-11406	SPACER B	スパ'ーサB	(1)
29		SD-0500721-SP	HINGE SCREW D= 5 H= 7.2	タ'ンネシ' D=5 H=7.2	(1)
30		B3031-141-H00	CONNECTING STUD	タ'キカ'イト'コロ	(1)
31		SM-6040602-TP	SCREW M4 L=6	ロツカクアナホ'ルト M4X0.7 L=6	2
32		SM-6052502-TP	SCREW M5X0.8 L=25	ロツカクアナホ'ルト	2
33		SS-8110422-TP	SCREW 11/64-40 L=4	トメネシ' 11/64-40 L=4	4
34		WP-0520656-SA	WASHER 5.2X9.5X0.6	ヒラサ'カ'ネ 5.2X9.5X0.6	2
35		107-28301	TERMINAL BASE	タンシタ'イ	1
36		SM-6031202-TP	SCREW M3X0.5 L=12	ロツカクアナホ'ルト	1
37		HW-5001400-00	2-C CABLE	キヤブ'タイヤコト' 0.18X12X2	1
38		107-32204	CORD BUSH	コト'ブ'ツシュ	1
39	#01	107-41759	GROUND WIRE ASM.	ク'ラント'センクミ	1
40		WT-0530002-KS	TOOTHED WASHER D=5.3	ハツキサ'カ'ネ D=5.3	1
41		SS-6111140-SP	SCREW 11/64-40 L=11	ヒラネシ' 11/64-40 L=11	1
42		EA-9500B02-00	CABLE BAND 150	ケツソクハ'ソト' 150	1
43		NM-6040001-SC	NUT M4	ロツカクナツト M4	1
44		D6043-555-B00	PIN TERMINAL, MALE	ヒ'ソ'ン タ-ミナル オス	2
45		D6028-555-BOA	9-POLE PLUG, WHITE	9P ナイロソフ'ラグ' シロ	1
46		107-27907	DRIVING LINK B	ト'ウメスクト'ウリンクB	1
47		CS-0790731-SH	THRUST COLLAR	スラストウケ	2
48		107-54604	SOLENOID ARM GUIDE PLATE	ソレノイト'ウテ'カ'イト'イタ	1
49		SM-4040601-SB	SCREW M4 L=6	ナハ'コネシ' M4X0.7 L=6	1
50		M9638-110-000	12-POLE RECEPTACLE COVER	リセフ'タクルカハ' 12P	1
51		100-04109	GROUND MARK	ク'ラント'マ-ク	1

NOTE (注記) #01...FOR JE, JUS (HEAD WHEN DELIVERING ONLY.)

JE, JUS向け (頭部出荷時のみ)

8. LEFT HOOK SHAFT BASE THREAD TRIMMER COMPONENTS(FOR LU-2266N-7)

左釜軸台糸切り関係 (LU-2266N-7用)

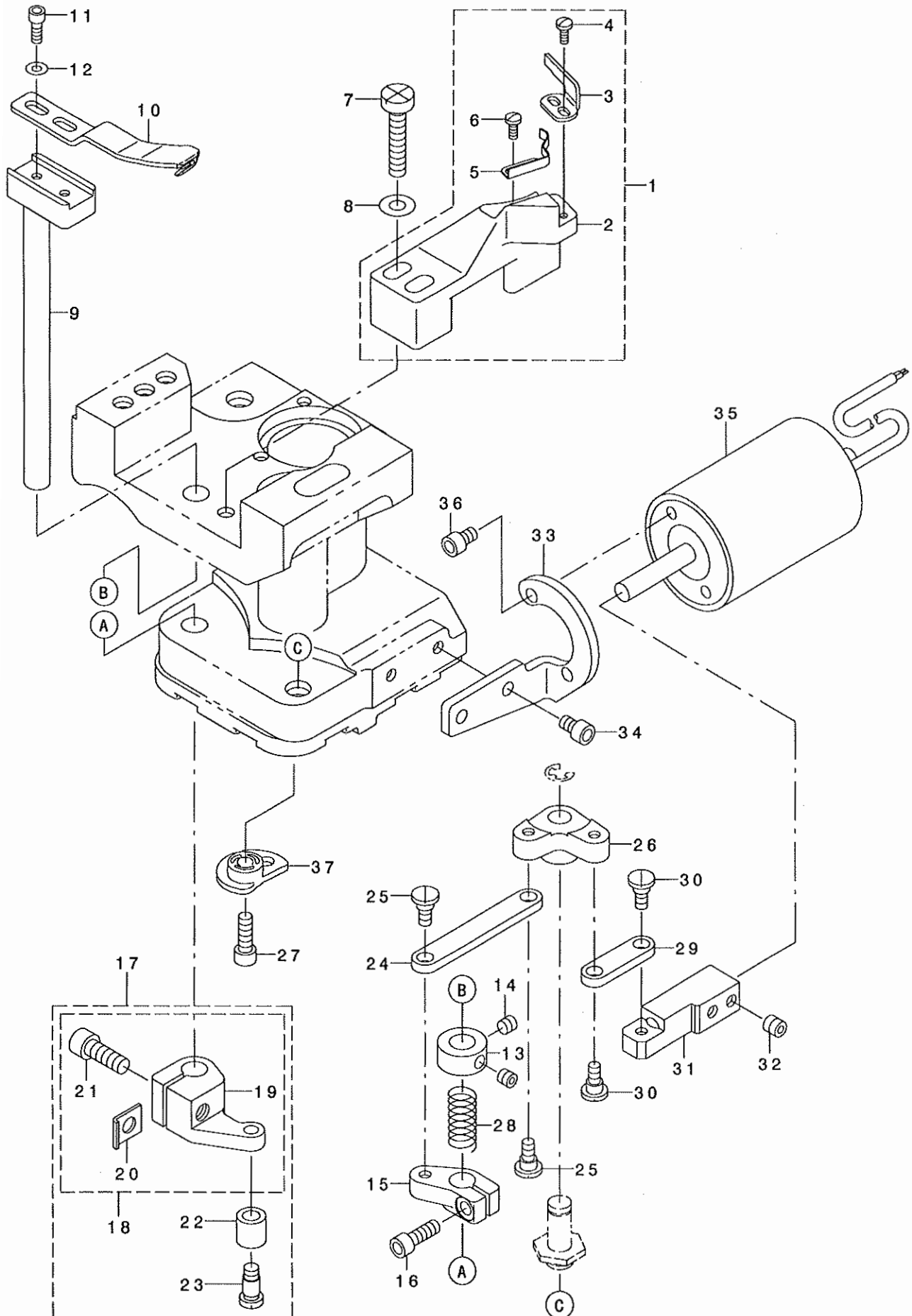

REF. NO	NOTE	PART NO.	DESCRIPTION	クニメシ	Qty
1		107-26552	FIXED KNIFE BASE ASM.	コテイメスタイ クミ	1
2		107-26503	FIXED KNIFE BASE	コテイメスタイ	(1)
3		107-26404	FIXED KNIFE	コテイメス	(1)
4		SS-7060610-SP	SCREW 3/32-56 L= 5.5	マルヒラネシ 3/32-56 L=5.5	(2)
5		107-26909	CLAMP SPRING	クランフ ハネ	(1)
6		SS-7060610-SP	SCREW 3/32-56 L= 5.5	マルヒラネシ 3/32-56 L=5.5	(2)
7		SM-6052502-TP	SCREW M5X0.8 L=25	ロツカクアナホ ルト	2
8		WP-0520656-SA	WASHER 5.2X9.5X0.6	ヒラサカネ 5.2X9.5X0.6	2
9		107-26800	MOVING KNIFE SHAFT	トウメスシク	1
10		107-26305	MOVING KNIFE	トウメス	1
11		SM-6030802-TP	SCREW M3X0.5 L=8	ロツカクアナホ ルト M3X0.5 L=8	2
12		WP-0320501-SC	WASHER M3	ヒラサカネ 3.2X7X0.5	2
13		CS-0790731-SH	THRUST COLLAR	スラストウケ	1
14		SS-8110422-TP	SCREW 11/64-40 L=4	トメネシ 11/64-40 L=4	2
15		107-71806	DRIVING ARM C	トウメスクトウウデ C	1
16		SM-6041202-TP	SCREW M4X0.7 L=12	ロツカクアナホ ルト	1
17		107-28160	DRIVING ARM A COMPL.	トウメスクトウウデ A(クツコウ)	1
18		107-28152	DRIVING ARM A ASM.	トウメスクトウウデ A(クミ)	(1)
19		107-28103	DRIVING ARM A	トウメスクトウウデ A	(1)
20		107-11406	SPACER B	スパ-サB	(1)
21		SM-6051402-TP	SCREW M5X0.8 L=14	ロツカクアナホ ルト	(1)
22		B3031-141-H00	CONNECTING STUD	タキカイトコロ	(1)
23		SD-0500721-SP	HINGE SCREW D= 5 H= 7.2	タシネシ D=5 H=7.2	(1)
24		107-71905	DRIVING LINK A	トウメスクトウリソクA	1
25		SD-0500301-SP	HINGE SCREW D= 5 H= 3	タシネシ D=5 H=3	2
26		107-72507	DRIVING ARM E	トウメスクトウウデ E	1
27		SM-6041202-TP	SCREW M4X0.7 L=12	ロツカクアナホ ルト	3
28		B2311-019-000	TENSION SPRING	ハネ	1
29		107-72002	DRIVING LINK B	トウメスクトウリソクB	1
30		SD-0500301-SP	HINGE SCREW D= 5 H= 3	タシネシ D=5 H=3	2
31		107-72101	SOLENOID ARM, LEFT	イトキリソレノイトウデ (ヒタリ)	1
32		SM-8050502-TP	SCREW M5 L=5	トメネシ	2
33		107-72200	MAGNET FITTING BASE, LEFT	イトキリソレノイトトリツケイタ(ヒタリ)	1
34		SM-6040602-TP	SCREW M4 L=6	ロツカクアナホ ルト M4X0.7 L=6	2
35		107-72804	THREAD CUTTING SOLENOID	イトキリソレノイト	1
36		SM-6040602-TP	SCREW M4 L=6	ロツカクアナホ ルト M4X0.7 L=6	2
37		107-27709	THREAD CUTTING CAM	イトキリカ	1

# 9. RIGHT HOOK SHAFT BASE & HOOK COMPONENTS

右金軸台・金関係

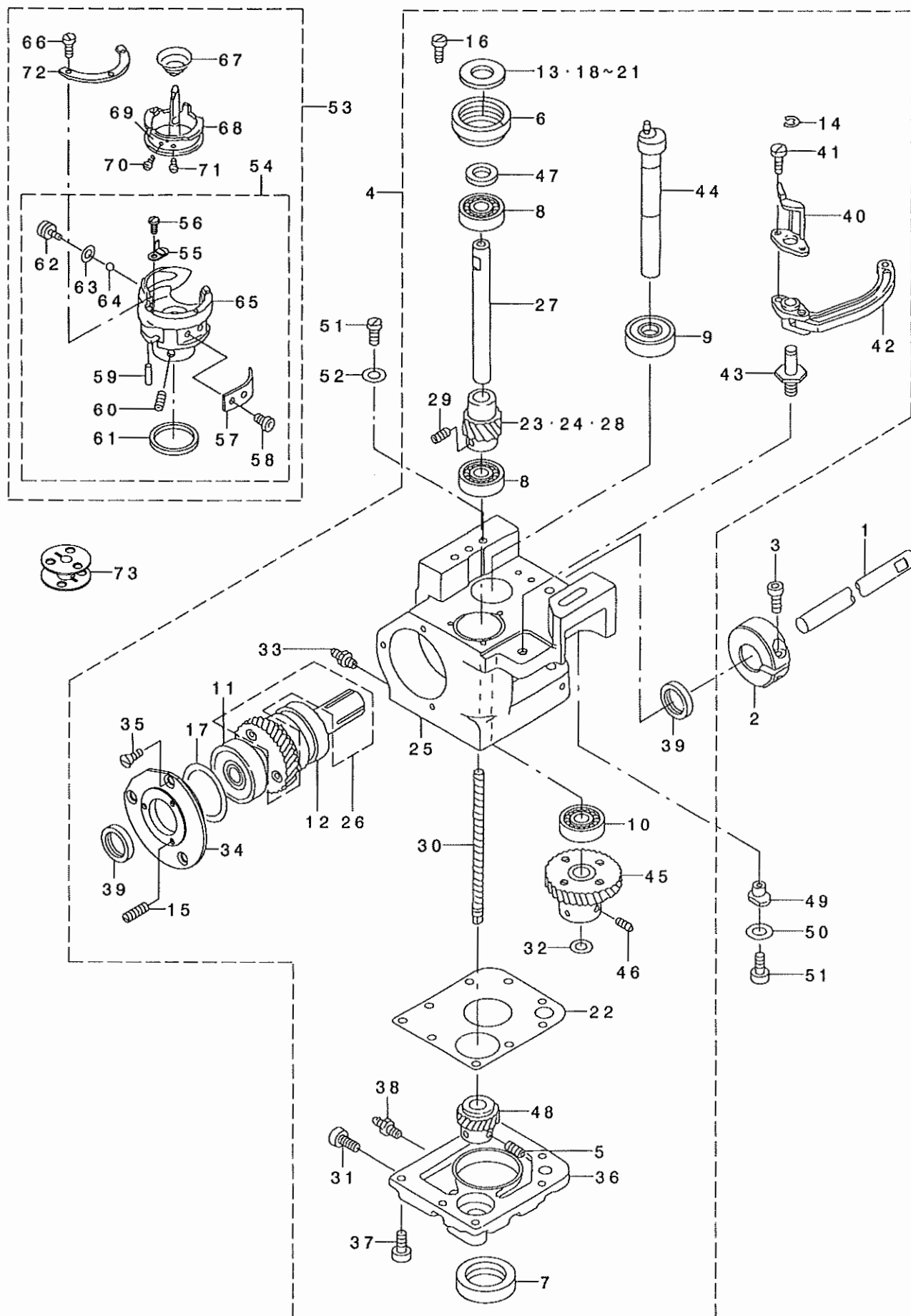

REF. NO	NOTE	PART NO.	DESCRIPTION	キ ャ ム イ	Qty
1	#02	107-22403	LOWER SHAFT B	シタシ'ク B	1
2		107-24607	SET COLLAR	シタシ'クセツカラ-	1
3		SM-6051402-TP	SCREW M5X0.8 L=14	ロツカクアナホ'ネ	1
4		107-70352	HOOK SHAFT BASE RIGHT ASM.	カマシ'ク'イ(ミキ')クミ	1
5		SM-8050502-TP	SCREW M5 L=5	トメネシ'	(2)
6		107-55601	BEARING COLLAR	カマシ'クハ'アリソク'ウケ	(1)
7		107-26107	OIL SEAL	オ-フ'ナ-ジ'クオイルシ-ル	(1)
8		B1215-804-000	BALL BEARING D	シユシ'ク'ホ'-ルハ'アリソク' D	(2)
9		SB-1100009-00	BEARING	コロカ'リシ'クウケ	(1)
10		SB-1100010-00	BEARING	コロカ'リシ'クウケ	(1)
11		SB-1150004-00	RADIAL BEARING	ラジ'アルシ'クウケ	(1)
12		SB-1150009-00	BEARING	コロカ'リシ'クウケ	(2)
13	#01	101-11201	THRUST WASHER, F	カマシ'クウメタル スラストイタ 1.4	(1)
14		RE-0400000-KO	E-RING 4	Eカ'タメタ 4	(1)
15		SS-8080610-SP	SCREW 1/8-44 L=5.5	トメネシ' 1/8-44 L=5.5	(3)
16		SS-6111140-SP	SCREW 11/64-40 L=11	ヒラネシ' 11/64-40 L=11	(3)
17		RO-3573501-00	O-RING	Oリング'	(1)
18	#01	101-12605	THRUST WASHER 1.7	カマシ'クウメタル スラストイタ 1.7	(1)
19	#01	101-12704	THRUST WASHER 1.8	カマシ'クウメタル スラストイタ 1.8	(1)
20	#01	101-09809	THRUST WASHER, B	カマシ'クウメタル スラストイタ B	(1)
21	#01	101-12506	THRUST WASHER 1.6	カマシ'クウメタル スラストイタ 1.6	(1)
22		107-70402	HOOK SHAFT BOTTOM PACKING	カマシ'ク'イタイタハ'ツキン	(1)
23	#01	107-39308	HOOK SHAFT SCREW GEAR	カマシ'クネシ'ハク'ルマ	(1)
24	#01	107-39407	HOOK SHAFT SCREW GEAR	カマシ'クネシ'ハク'ルマ	(1)
25		107-70303	HOOK SHAFT BASE, RIGHT	イトキリカマシ'ク'イ(ミキ')	(1)
26		107-22353	LOWER SHAFT A ASM.	シモシ'クA(クミ)	(1)
27		107-23708	HOOK SHAFT	カマシ'ク	(1)
28		107-23807	SCREW GEAR	カマシ'クネシ'ハク'ルマ	(1)
29		SM-8050502-TP	SCREW M5 L=5	トメネシ'	(2)
30		107-23906	LUBRICATING SHAFT	キユウシ'ク	(1)
31		SM-4030601-SC	SCREW M3 X 6	ナハ'コネシ' M3X0.5 L=6	(1)
32		RO-0982401-00	RUBBER RING	Oリング'	(1)
33		SQ-1150451-MZ	CONNECTING SCREW	チユ-フ'レソクツネシ'	(1)
34		107-24201	BEARING HOLDER	シタシ'クハ'アリソク'ホ'ルダ'	(1)
35		SS-1110840-SP	SCREW 11/64-40 L=8	チラネシ' 11/64-40 L=8	(3)
36		107-75302	HOOK SHAFT LOWER PLATE, RIGHT	カマシ'ク'イタイタハ'(ミキ')	(1)
37		SM-6040802-TP	SCREW M4X0.7 L=8	ロツカクアナホ'ネ	(9)
38		SQ-1150451-MZ	CONNECTING SCREW	チユ-フ'レソクツネシ'	(1)
39		107-24805	OIL SEAL	シタシ'クオイルシ-ル	(2)
40		107-25000	OPENER	オ-フ'ナ-	(1)
41		SS-6080610-TP	SCREW 1/8-44 L=6	ヒラネシ' 1/8-44 L=6	(2)
42		107-25158	OPENER ARM COMPL.	オ-フ'ナ-ウヂ'(クツコ'ウ)	(1)
43		107-70501	OPNER ARM SHAFT B	オ-フ'ナ-ウヂ'シ'ク B	(1)
44		107-25604	OPENER SHAFT	オ-フ'ナ-ジ'ク	(1)
45		107-25752	OPENER SHAFT SCREW GEAR ASM.	オ-フ'ナ-ジ'クネシ'ハク'ルマ クツコ'ウ	(1)
46		SM-8050502-TP	SCREW M5 L=5	トメネシ'	(2)
47		107-24706	BEARING SPACER	カマシ'クハ'アリソク'スハ'-サ-	(1)
48		107-25901	OPENER HOOK SHAFT SCREW GEAR	オ-フ'ナ-カマシ'クネシ'ハク'ルマ	(1)
49		107-26206	ECCENTRICITY COLLAR	カマシ'ク'イハソク'ビ'ン	1
50		WP-0651056-SH	WASHER 6.5X11X1	ヒラサ'カ'ネ 6.5X11X1	1
51		SM-6062002-TP	SCREW M6 L=20	ロツカクアナホ'ネ M6 L=20	2
52		WP-0641601-SD	WASHER M6	ヒラサ'カ'ネ ミカ'キマル M6	1
53		107-22551	HOOK ASM.	カマ'クミ	1
54		107-52467	OUTER HOOK ASM.	ソトカ'マ'クミ	(1)
55		107-52202	OIL CAP	ア'ラフタ	(1)
56		107-52301	OIL CAP SETSCREW	ア'ラフタトメネシ'	(1)
57		107-23013	NEEDLE HOLDER	ハリウケ	(1)
58		107-23203	NEEDLE HOLDER SETSCREW	ハリウケトメネシ'	(2)
59		107-28509	FILTER	エリヨウチヨウセツフィルタ-	(1)
60		SM-8050602-TP	SCREW M5 L=6	トメネシ' M5X0.8 L=6	(2)
61		107-28508	RUBBER RING	キユウエリソク'	(1)
62		107-22601	ADJUSTING SCREW	エリヨウチヨウセツネシ'	(1)
63		107-28707	RUBBER RING	エリヨウチヨウセツネシ' Oリング'	(1)
64		107-28400	URETHAN BALL	ウレタンホ'-ル	(1)
65		107-52418	OUTER HOOK	ソトカ'マ	(1)
66		107-23104	PRESSER SETSCREW	ウチカ'マオサエトメネシ'	(3)
67		107-23500	IDLING PREVENTION SPRING	クウテンホ'ウシハ'ネ	(1)
68		107-22700	INNER HOOK	ウチカ'マ	(1)
69		107-22908	TENSION SPRING	シタイトチヨウシハ'ネ	(1)
70		107-23302	ADJUSTING SCREW	シタイトチヨウシハ'ネ チョウセツネシ'	(1)
71		107-23401	TENSION SPRING SETSCREW	シタイトチヨウシハ'ネトメネシ'	(1)
72		107-22809	INNER HOOK PRESSER	ウチカ'マオサエ	(1)
73		107-59603	ALUMINUM BOBBIN (DOUBLE-CUT)	アルミホ'ビン(ロ-レットツキ)	1

NOTE (注記)

#01... SELECTIVE PARTS  
#02... FOR LU-2216N-7

選択部品  
LU-2216N-7用

10. LEFT HOOK SHAFT BASE COMPONENTS(FOR LU-2266N-7)

左釜軸台關係 (LU-2266N-7用)

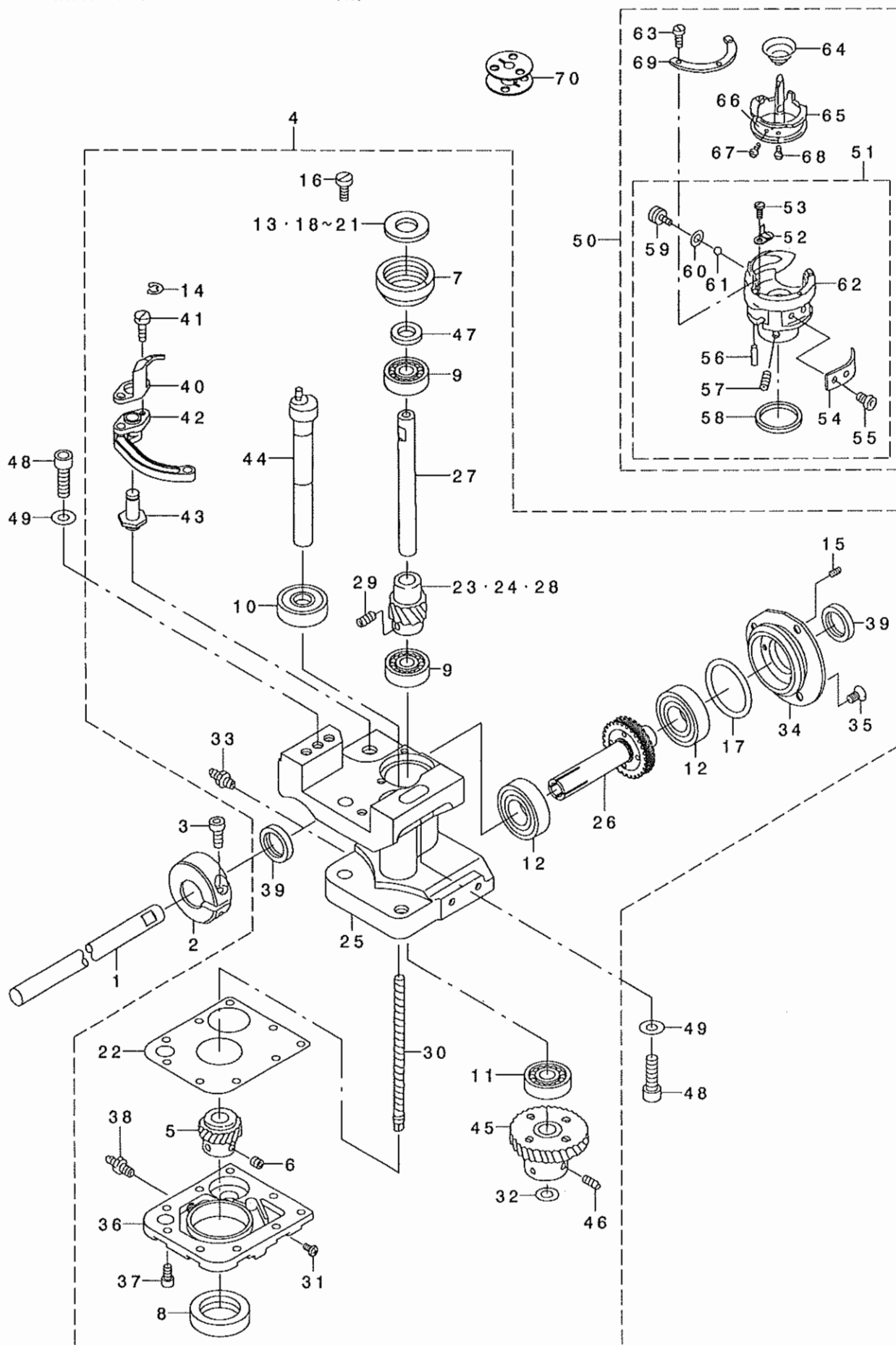

REF. NO	NOTE	PART NO.	DESCRIPTION	ヒョウメイ	Qty
1		107-72705	LOWER SHAFT C	シモシ'クC	1
2		107-24607	SET COLLAR	シタン'クセツカラ-	1
3		SM-6051402-TP	SCREW M5X0.8 L=14	ロツカクアナホ'ルト	1
4		107-71756	HOOK SHAFT BASE LEFT ASM.	カマシ'クタ'イ(ヒタ'リ)クミ	1
5		107-25901	OPENER HOOK SHAFT SCREW GEAR	オ-プ'ナ-カマシ'クネシ'ハク'ルマ	(1)
6		SM-8050502-TP	SCREW M5 L=5	トメネシ'	(2)
7		107-55601	BEARING COLLAR	カマシ'クハ'アリソク'ウケ	(1)
8		107-26107	OIL SEAL	オ-プ'ナ-シ'クオイルシ-ル	(1)
9		B1215-804-000	BALL BEARING D	シユシ'クホ'-ルハ'アリソク' D	(2)
10		SB-1100009-00	BEARING	ゴロカ'リソク'クウケ	(1)
11		SB-1100010-00	BEARING	ゴロカ'リソク'クウケ	(1)
12		SB-1150004-00	RADIAL BEARING	ラジ'アルシ'クウケ	(2)
13	#01	101-11201	THRUST WASHER, F	カマシ'クウメタル スラストイタ 1.4	(1)
14		RE-0400000-KO	E-RING 4	Eカ'タメツ 4	(1)
15		SS-8080610-SP	SCREW 1/8-44 L=5.5	トメネシ' 1/8-44 L=5.5	(3)
16		SS-6111140-SP	SCREW 11/64-40 L=11	ヒラネシ' 11/64-40 L=11	(3)
17		RO-3573501-00	O-RING	Oリソク'	(1)
18	#01	101-12605	THRUST WASHER 1.7	カマシ'クウメタル スラストイタ 1.7	(1)
19	#01	101-12704	THRUST WASHER 1.8	カマシ'クウメタル スラストイタ 1.8	(1)
20	#01	101-09809	THRUST WASHER, B	カマシ'クウメタル スラストイタ B	(1)
21	#01	101-12506	THRUST WASHER 1.6	カマシ'クウメタル スラストイタ 1.6	(1)
22		107-70402	HOOK SHAFT BOTTOM PACKING	カマシ'クタ'イシタイタハ'ツキン	(1)
23	#01	107-39308	HOOK SHAFT SCREW GEAR	カマシ'クネシ'ハク'ルマ	(1)
24	#01	107-39407	HOOK SHAFT SCREW GEAR	カマシ'クネシ'ハク'ルマ	(1)
25		107-71707	HOOK SHAFT BASE, LEFT	イトキリカマシ'クタ'イ(ヒタ'リ)	(1)
26		107-22353	LOWER SHAFT A ASM.	シモシ'クA(クミ)	(1)
27		107-23708	HOOK SHAFT	カマシ'ク	(1)
28		107-23807	SCREW GEAR	カマシ'クネシ'ハク'ルマ	(1)
29		SM-8050502-TP	SCREW M5 L=5	トメネシ'	(2)
30		107-23906	LUBRICATING SHAFT	キュウユシ'ク	(1)
31		SM-4030601-SC	SCREW M3 X 6	ナハ'コネシ' M3X0.5 L=6	(1)
32		RO-0982401-00	RUBBER RING	Oリソク'	(1)
33		SQ-1150451-MZ	CONNECTING SCREW	チュ-プ'レンケツネシ'	(1)
34		107-24201	BEARING HOLDER	シタン'クハ'アリソク'ホルダ-	(1)
35		SS-1110840-SP	SCREW 11/64-40 L=8	ヒラネシ' 11/64-40 L=8	(3)
36		107-72408	HOOK SHAFT LOWER PLATE, LEFT	カマシ'クタ'イシタイタ(ヒタ'リ)	(1)
37		SM-6040802-TP	SCREW M4X0.7 L=8	ロツカクアナホ'ルト	(9)
38		SQ-1150451-MZ	CONNECTING SCREW	チュ-プ'レンケツネシ'	(1)
39		107-24805	OIL SEAL	シタン'クオイルシ-ル	(2)
40		107-25000	OPENER	オ-プ'ナ-	(1)
41		SS-6080610-TP	SCREW 1/8-44 L=6	ヒラネシ' 1/8-44 L=6	(2)
42		107-25158	OPENER ARM COMPL.	オ-プ'ナ-ウデ' (ケツゴ'ウ)	(1)
43		107-70501	OPNER ARM SHAFT B	オ-プ'ナ-ウデ'シ'ク B	(1)
44		107-25604	OPENER SHAFT	オ-プ'ナ-シ'ク	(1)
45		107-25752	OPENER SHAFT SCREW GEAR ASM.	オ-プ'ナ-シ'クネシ'ハク'ルマ ケツゴ'ウ	(1)
46		SM-8050502-TP	SCREW M5 L=5	トメネシ'	(2)
47		107-24706	BEARING SPACER	カマシ'クハ'アリソク'スハ'-サ-	(1)
48		SM-6062002-TP	SCREW M6 L=20	ロツカクアナホ'ルト M6 L=20	2
49		WP-0641601-SD	WASHER M6	ヒラサ'ガ'ネ ミカ'キマル M6	2
50		107-22551	HOOK ASM.	カマ'クミ	1
51		107-52467	OUTER HOOK ASM.	ソトカ'マ'クミ	(1)
52		107-52202	OIL CAP	ア'ラフタ	(1)
53		107-52301	OIL CAP SETSCREW	ア'ラフタトメネシ'	(1)
54		107-23013	NEEDLE HOLDER	ハリウケ	(1)
55		107-23203	NEEDLE HOLDER SETSCREW	ハリウケ トメネシ'	(2)
56		107-28509	FILTER	エリヨウチヨウヒツフィルタ-	(1)
57		SM-8050602-TP	SCREW M5 L=6	トメネシ' M5X0.8 L=6	(2)
58		107-28608	RUBBER RING	キュウユリソク'	(1)
59		107-22601	ADJUSTING SCREW	エリヨウチヨウヒツネシ'	(1)
60		107-28707	RUBBER RING	エリヨウチヨウヒツネシ' Oリソク'	(1)
61		107-28400	URETHAN BALL	ウレタンホ'-ル	(1)
62		107-52418	OUTER HOOK	ソトカ'マ	(1)
63		107-23104	PRESSER SETSCREW	ウチカ'マオサエ トメネシ'	(3)
64		107-23500	IDLING PREVENTION SPRING	クウテンホ'ウシハ'ネ	(1)
65		107-22700	INNER HOOK	ウチカ'マ	(1)
66		107-22908	TENSTON SPRING	シタイトチヨウシハ'ネ	(1)
67		107-23302	ADJUSTING SCREW	シタイトチヨウシハ'ネ チョウヒツネシ'	(1)
68		107-23401	TENSION SPRING SETSCREW	シタイトチヨウシハ'ネ トメネシ'	(1)
69		107-22809	INNER HOOK PRESSER	ウチカ'マオサエ	(1)
70		107-59603	ALUMINUM BOBBIN (DOUBLE-CUT)	アルミホ'-ン(ロ-レットツキ)	1

NOTE (注記)

#01...SELECTIVE PARTS

選択部品

# 11. THREAD TENSION COMPONENTS

糸調子関係

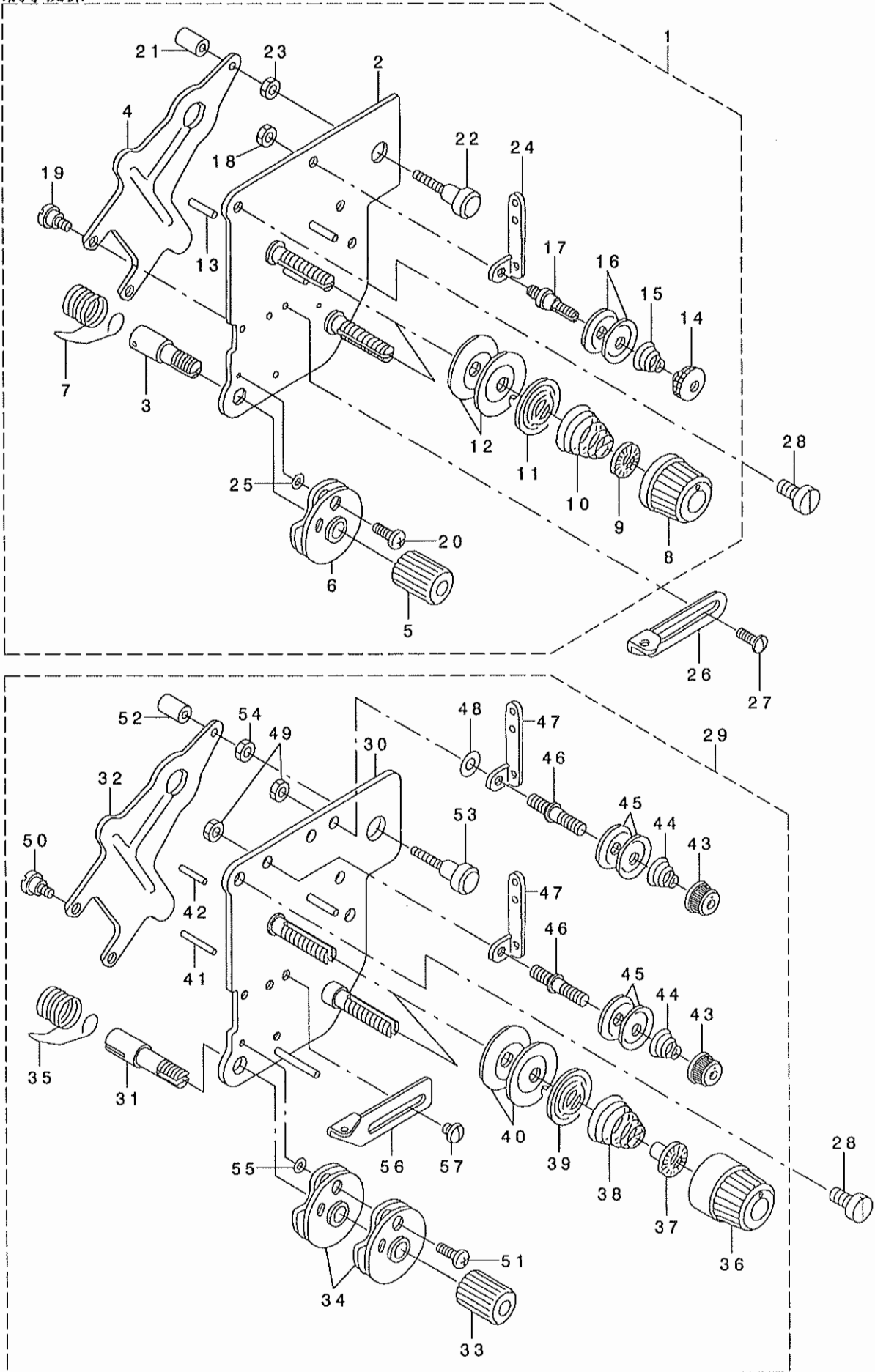



REF. NO	NOTE	PART NO.	DESCRIPTION	ク ヲ ム イ	Qty
1	#02	107-02561	THREAD TENSION ASM.	イトチヨウシ クミ	1
2		107-02553	THREAD TENSION JUNCTION	イトチヨウシダ' イタ クヅコ' ウ	(1)
3		103-20109	SCREW STUD	イトトリハ' ネジ' ク	(1)
4		107-02603	THREAD LOOSENING PLATE	イトコムメイタ	(1)
5		103-20208	THRED TENSION STUD NUT	イトトリハ' ネジ' クナツト	(1)
6		107-41452	THREAD TAKE-UP GUIDE ASM.	イトトリハ' ネアンナイ(クミ)	(1)
7		107-02405	THREAD TAKE-UP SPRING	イトトリハ' ネ	(1)
8		107-44704	THREAD TENSION NUT	イトチヨウシナツト	(2)
9		107-44803	ROTATION AND STOP	イトチヨウシサラカイトント' メ	(2)
10		B3129-012-A00	TENSION SPRING	イトチヨ-シハ' ネ A	(2)
11		107-44902	THREAD TENSION PLATE SUPPERSSI	イトチヨウシサラオサエ	(2)
12		B3126-352-000	TENSION DISC	イトチヨ-シ サラ	(4)
13		107-41601	THREAD LOOSEN PIN	イトコムメビ' ソ	(2)
14		B3216-047-000	BOBBIN WINDER TENSION NUT	イトチヨ-シ ナツト	(1)
15		D3168-555-HOB	TENSION SPRING NO.1	ダ' イ1 イトチヨウシハ' ネ	(1)
16		107-41106	FIRST THREAD TENSION PLATE	ダ' イイチイトチヨウシサラ	(2)
17		107-03304	FIRST THREAD TENSION BAR	ダ' イイチイトチヨウシホ' ウ	(1)
18		NS-6110310-SP	NUT 11/64-40	ロツカクナツト 11/64-40	(1)
19		SD-0470281-SP	HINGE SCREW D=4.7 H=2.8	ダ' ソネジ' D=4.7 H=2.8	(2)
20		107-41502	STOP SCREW	イトトリハ' ネアンナイサラトメネジ'	(1)
21		107-02702	THREAD LOOSENING PIN	イトコムメオシビ' ソ	(1)
22		107-02801	THREAD LOOSENING SCREW	イトコムメオシネジ'	(1)
23		NM-6040003-SC	NUT M4	ロツカクナツト M4	(1)
24		107-03205	FIRST THREAD TENSION GUIDE	ダ' イイチイトチヨウシアンナイ	(1)
25		WP-0320501-SC	WASHER M3	ヒラザ' カ' ネ 3.2X7X0.5	(1)
26	#02	107-03106	BALANCE THREAD GUIDE	テンビ' ソイトアンナイ	1
27	#02	SS-5090420-SP	SCREW 9/64-40 L=3.5	トラスネジ' 9/64-40 L=3.5	2
28		SS-6121010-SP	SCREW 3/16-28 L=10	ヒラネジ' 3/16-28 L=10	2
29	#01	107-73364	THREAD TENSION ASM.	イトチヨウシ(クミ)	1
30		107-73356	THREAD TENSION JUNCTION	イトチヨウシダ' イタ(クヅコ' ウ)	(1)
31		107-73505	SCREW STUD	イトトリハ' ネジ' ク	(1)
32		107-02603	THREAD LOOSENING PLATE	イトコムメイタ	(1)
33		103-20208	THRED TENSION STUD NUT	イトトリハ' ネジ' クナツト	(1)
34		107-41452	THREAD TAKE-UP GUIDE ASM.	イトトリハ' ネアンナイ(クミ)	(2)
35		B3128-526-000	THREAD TAKE-UP SPRING	イトトリハ' ネ	(1)
36		119-56703	THREAD TENSION KNOB, RED	イトチヨウシツマミ (アカ)	(2)
37		B3112-704-000	TENSION SPRING BUSHING	ハ' ネ フ' ツシユ	(2)
38		B3129-053-000	TENSION SPRING	イトチヨ-シハ' ネ	(2)
39		B3132-552-000	THREAD TENSION DISK PRESSER	イトチヨ-シ サラオサエ	(2)
40		B3126-012-000	THREAD TENSION DISK	イトチヨ-シサラ	(4)
41		107-73703	THREAD LOOSEN PIN,RIGHT	イトコムメビ' ソ(ミキ')	(1)
42		107-73802	THREAD LOOSEN PIN,LEFT	イトコムメビ' ソ(ヒダ' リ)	(1)
43		110-72402	THREAD TENSION NUT	ダ' イ1 イトチヨウシ ナツト	(2)
44		110-45101	THREAD TENSION SPRING	ダ' イイチ イトチヨウシハ' ネ	(2)
45		107-41106	FIRST THREAD TENSION PLATE	ダ' イイチイトチヨウシサラ	(4)
46		107-73406	FIRST THREAD TENSION BAR	ダ' イイチイトチヨウシホ' ウ	(2)
47		107-03205	FIRST THREAD TENSION GUIDE	ダ' イイチイトチヨウシアンナイ	(2)
48		WP-0482086-SD	WASHER 4.8X11.5X2	ヒラザ' カ' ネ 4.8X11.5X2	(1)
49		NS-6110310-SP	NUT 11/64-40	ロツカクナツト 11/64-40	(2)
50		SD-0470281-SP	HINGE SCREW D=4.7 H=2.8	ダ' ソネジ' D=4.7 H=2.8	(2)
51		SS-3061310-SP	SCREW 3/32-56 L=13	マルネジ'	(1)
52		107-02702	THREAD LOOSENING PIN	イトコムメオシビ' ソ	(1)
53		107-02801	THREAD LOOSENING SCREW	イトコムメオシネジ'	(1)
54		NM-6040003-SC	NUT M4	ロツカクナツト M4	(1)
55		WP-0320501-SC	WASHER M3	ヒラザ' カ' ネ 3.2X7X0.5	(1)
56		107-73109	BALANCE THREAD GUIDE	テンビ' ソイトアンナイ	(1)
57		SS-5090420-SP	SCREW 9/64-40 L=3.5	トラスネジ' 9/64-40 L=3.5	(2)

NOTE (注記)

#01...FOR LU-2266N-7  
#02...FOR LU-2216N-7

LU-2266N-7用  
LU-2216N-7用

## 12. LOWER THREAD WINDER MECHANISM COMPONENTS

下糸巻き装置関係

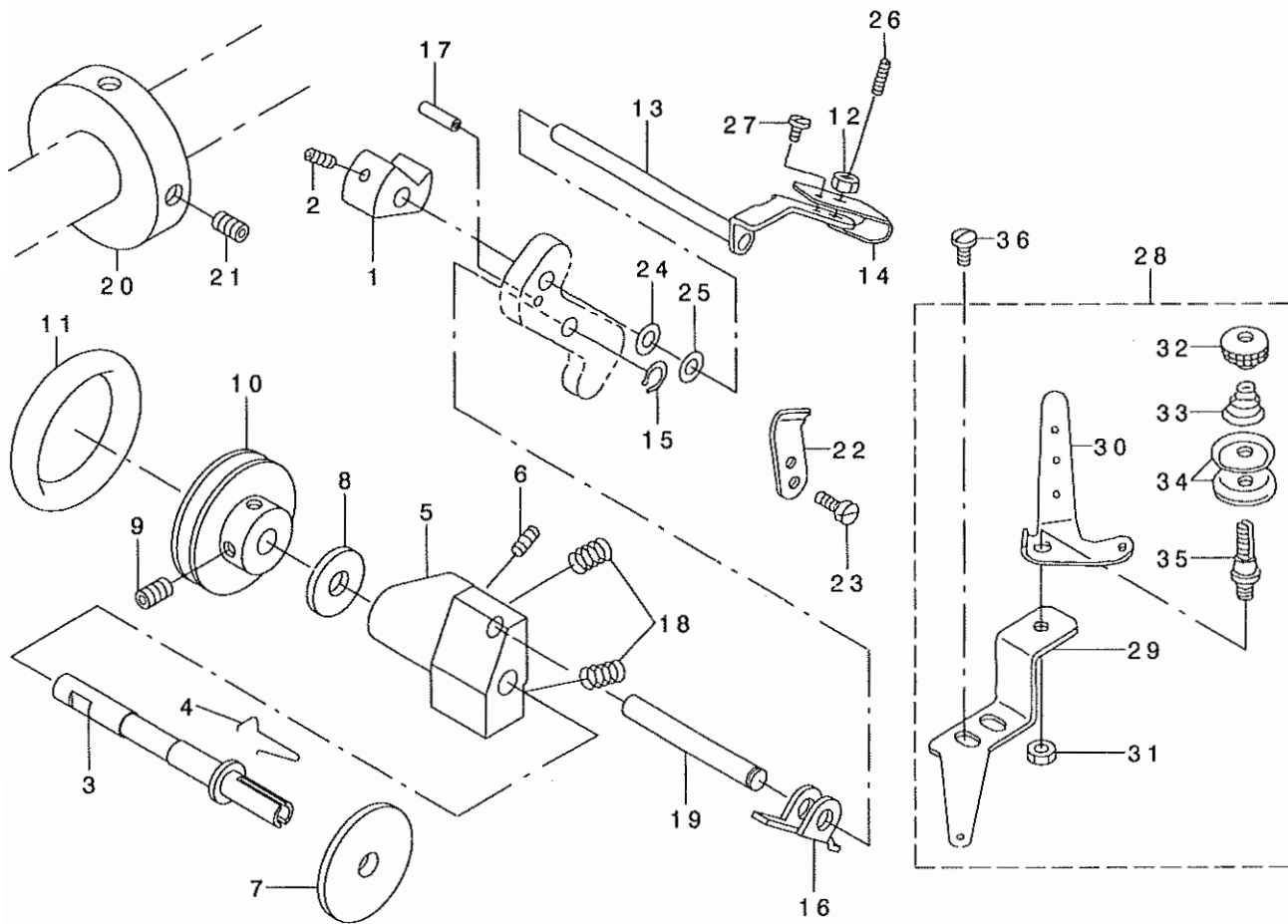

REF. NO	NOTE	PART NO.	DESCRIPTION	ヒソメイ	Qty
1		107-03502	BOBBIN CUM	ボビンカ	1
2		SM-8040602-TP	SCREW M4X0.7 L=6	ボネツ	1
3		107-03601	BOBBIN SHAFT	ボビンク	1
4		107-03700	BOBBIN SPRING	ボビンスプリング	1
5		107-03908	BOBBIN SHAFT BASE	ボビンクダ	1
6		SM-8040602-TP	SCREW M4X0.7 L=6	ボネツ	1
7		B3205-210-000	CUSHION	ボビンク	1
8		WP-0651056-SH	WASHER 6.5X11X1	ワシヤカネ 6.5X11X1	1
9		SS-7110810-SP	SCREW 11/64-40 L= 8.0	ワシヤネツ 11/64-40 L=8	2
10		B3211-210-000	BOBBIN WINDER WHEEL	ボビンクダ	1
11		B3212-210-000	FRICTION WHEEL	ボビンクダクダ	1
12		NS-6110360-SP	NUT	ボネツ	1
13		107-03452	BOBBIN PRESSER ASM.	ボビンプレスア	1
14		107-03809	BOBBIN PRESSER SPRING	ボビンプレスア	1
15		D2430-555-B00	SNAP RING	ボネツ	1
16		B3207-210-000	TRIP LATCH	ボビンクダクダ	1
17		PS-0200102-KH	SPRING PIN 2.0 X 10	ボネツ	1
18		B3208-210-000	SPRING A	ボビンクダクダ	2
19		107-04005	BOBBIN SHAFT BASE SHAFT	ボビンクダクダ	1
20		107-04807	BOBBIN FRICTION WHEEL	ボビンクダクダ	1
21		SM-8050602-TP	SCREW M5 L=6	ボネツ	2
22		105-02300	THREAD CUTTER	ボネツ	1
23		SS-6090620-SP	SCREW 9/64-40 L=6	ワシヤネツ 9/64-40 L=6	2
24		WP-0531001-SC	WASHER	ワシヤカネ 5.2X9.5X0.6	1
25		WP-0520656-SA	WASHER 5.2X9.5X0.6	ワシヤカネ 5.2X9.5X0.6	1
26		SS-8111610-SP	SCREW 11/64-40 L=15.5	ワシヤネツ 11/64-40 L=15.5	1
27		SS-7110340-SP	SCREW 11/64-40 L= 3.2	ワシヤネツ 11/64-40 L= 3.2	1
28		107-04153	BOBBIN THREAD GUIDE PLATE ASM.	ボビンア	1
29		107-04104	BOBBIN THREAD GUIDE PLATE	ボビンア	(1)
30		100-88003	THREAD GUIDE	ボビンア	(1)
31		NS-6110310-SP	NUT 11/64-40	ボネツ	(1)
32		B3216-047-000	BOBBIN WINDER TENSION NUT	ボネツ	(1)
33		D3168-555-H0B	TENSION SPRING NO.1	ボネツ	(1)
34		B3214-047-000	BOBBIN WINDER TENSION DISC	ボネツ	(2)
35		101-24204	THREAD TENSION POST, A	ボネツ	(1)
36		SS-7621040-SP	SCREW 3/16-32 L=9.5	ワシヤネツ 3/16-32 L=9.5	2

### 13. PRESSURE ADJUSTING COMPONENTS

押え圧調節関係

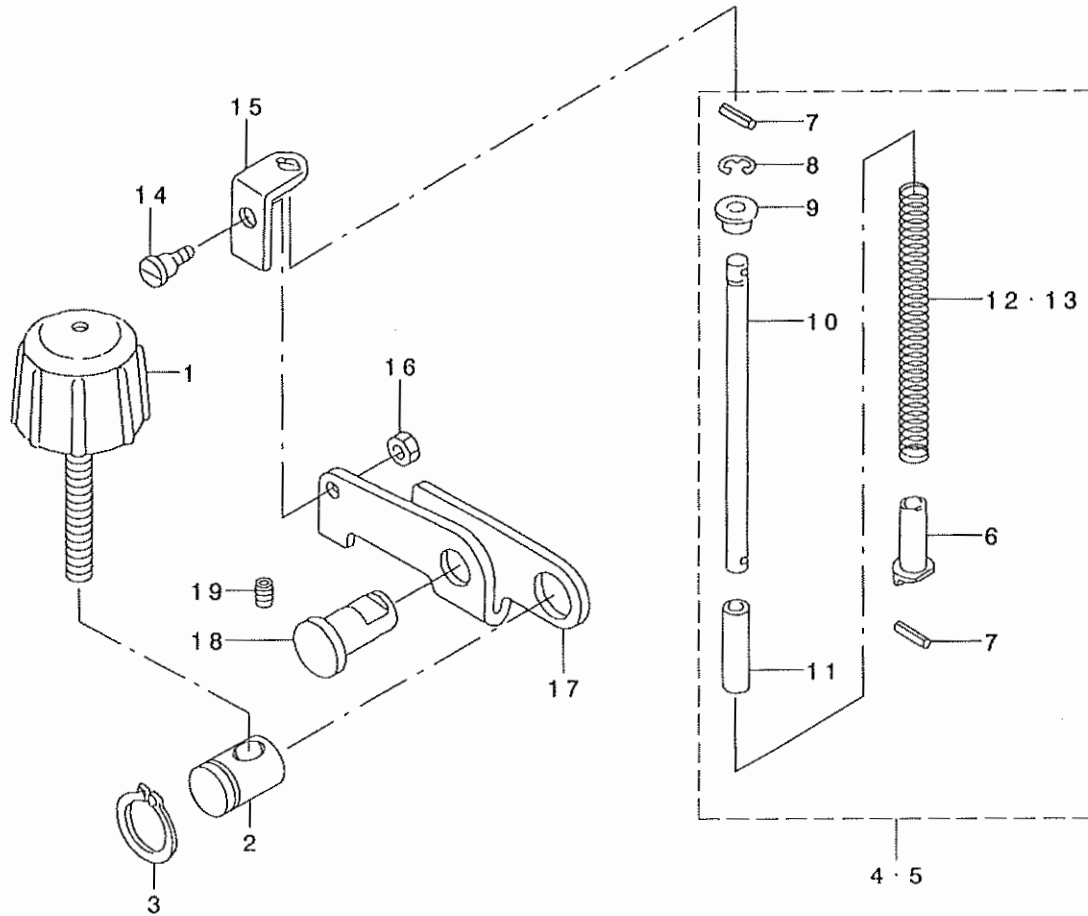

REF. NO	NOTE	PART NO.	DESCRIPTION	ヒョウメイ	Qty
1		107-43300	ADJUSTMENT DIAL	オサエチヨウセツタ' イヤル	1
2		107-16009	ADJUSTING HINGE PIN	オサエアツチヨウセツヒンシ' ビン	1
3		RC-1200001-KP	C-SHAPED SNAP RING	Cカ' タトメヲ	1
4		107-15951	ADJUSTMENT SPRING ASM.	オサエチヨウセツハ' ネ 1.8 クミ	1
5	#01	107-18351	ADJUSTMENT SPRING ASM.	オサエチヨウセツハ' ネ 1.4 クミ	1
6		107-15605	SPRING RECEIVING, LOWER	オサエチヨウセツハ' ネウケ(シタ)	(1)
7		PS-0300082-KH	SPRING PIN 3X8	スプリング' ビン 3.0X 8	(2)
8		RE-0500000-KO	E-RING	Eカ' タトメヲ 5	(1)
9		107-15506	SPRING RECEIVING, UPPER	オサエチヨウセツハ' ネウケ(ウエ)	(1)
10		107-16306	ADJUSTMENT SPRING AXIS	オサエアツチヨウセツハ' ネシ' ク	(1)
11		BP-6000000-00	VINYL PIPE	ビニール' ハ' イフ	(0.1)
12		107-15902	ADJUSTMENT SPRING 1.8	オサエチヨウセツハ' ネ(1.8)	(1)
13	#01	107-18302	ADJUSTMENT SPRING 1.4	オサエチヨウセツハ' ネ(1.4)	(1)
14		SD-0700332-SP	HINGE SCREW D= 7 H= 3.5	タ' ンネシ' D=7 H=3.5	1
15		107-16603	ADJUSTING SPRING SUPPORT	オサエアツチヨウセツハ' ネササエ	1
16		NS-6150430-SP	NUT 15/64-28	ロツカクナツト 15/64-28	1
17		107-16108	ADJUSTING ARM	オサエアツチヨウセツウデ'	1
18		107-16207	ADJUSTING ARM SHAFT	オサエチヨウセツウデ' シ' ク	1
19		SS-8120740-SP	SCREW 3/16-28 L=7	トメネシ' 3/16-28 L=7	1

NOTE (注記)

#01...OPTIONAL PARTS

オプ' シヨソ' 部品

14. PRESSER LIFTER, AUTOMATIC PRESSER LIFTER  
& TENSION RELEASE MECHANISM COMPONENTS

押え上げ・自動押え上げ・糸ゆるめ機構関係

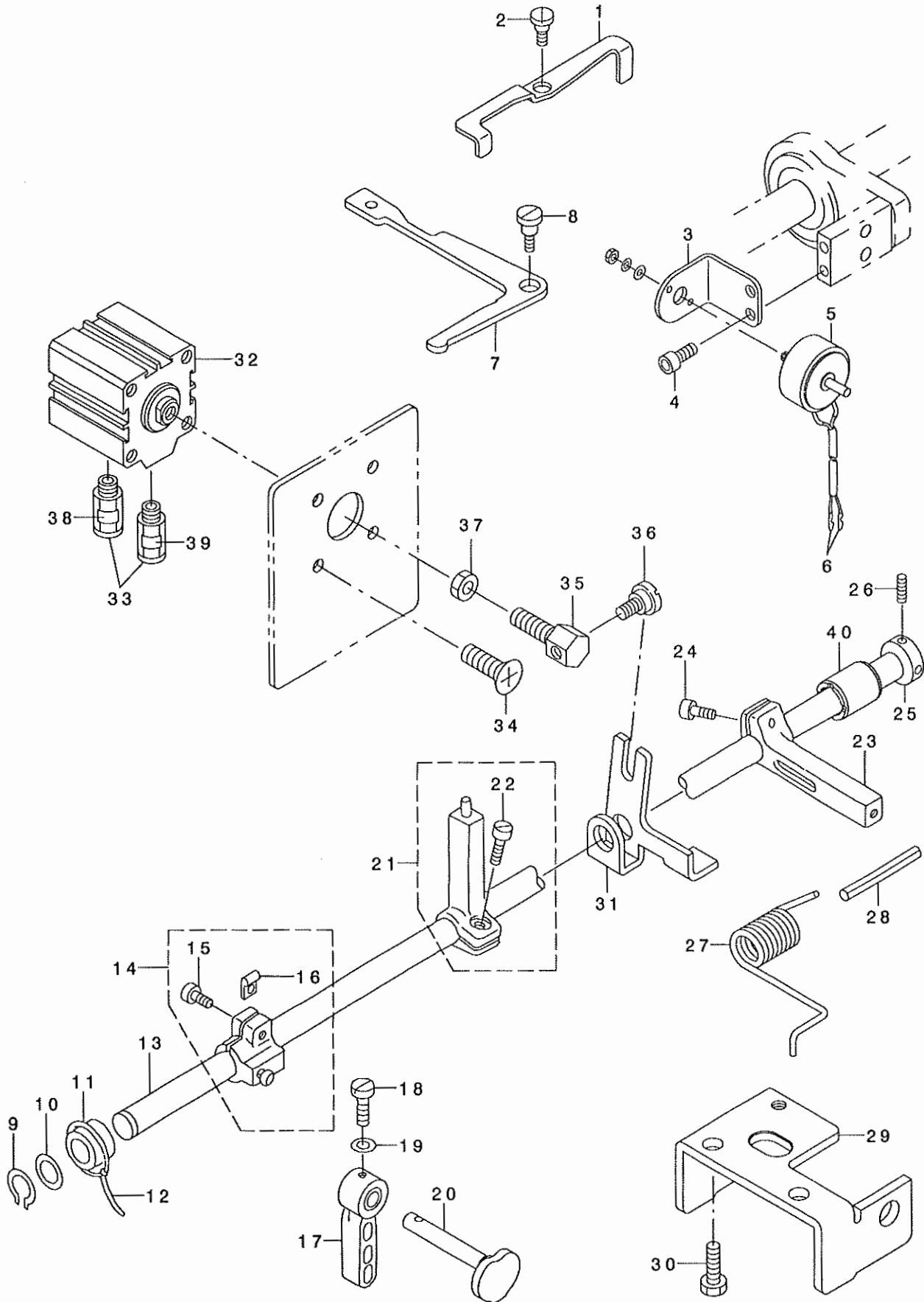

REF. NO	NOTE	PART NO.	DESCRIPTION	ヒ ヲ メ イ	Qty
1		107-29010	THREAD LOOSENING ARM	イトユルメウテ	1
2		SD-0790203-SP	HINGE SCREW D=7.94 H=2	タ'ンネシ' D=7.94 H=2	1
3		231-57506	SOLENOID FITTING PLATE	イトユルメソレノイト' トリツケイタ	1
4		SM-6051202-TP	SCREW M5X0.8 L=12	ロツカクアナホ' ルト M5X0.8 L=12	2
5		231-57605	THREAD LOOSENING SOLENOID	イトユルメソレノイト'	1
6		D6043-555-B00	PIN TERMINAL, MALE	ピ'ン タ-ミナル オス	2
7		107-28806	THREAD LOOSENING LEVER	イトユルメレハ' -	1
8		SD-0901201-TP	HINGE SCREW D=9 H=3.2	タ'ンネシ' D=9 H=3.2	1
9		RC-1200001-KP	C-SHAPED SNAP RING	Cカ' タトメワ	1
10		WP-1221016-SP	WASHER	ヒラサ' ガ' ネ	1
11		107-31008	KNEE LIFT FRONT METAL	ヒサ' アケ' シ' クマエメタル	1
12		CQ-2000000-00	OIL WICK	ユシシ	0.2
13		231-56904	KNEE LIFT SHAFT	ヒサ' アケ' シ' ク	1
14		107-29754	PRESSER LIFT ARM ASM.	オサエアケ' ウテ' (クミ)	1
15		SM-6051402-TP	SCREW M5X0.8 L=14	ロツカクアナホ' ルト	(1)
16		107-11406	SPACER B	スハ' -サB	(1)
17		110-71800	HAND LIFTER	オサエアケ' レハ' -	1
18		SS-7090910-TP	SCREW 9/64-40 L= 8.5	マルヒラネシ' 9/64-40 L=8.5	1
19		WP-0371016-SD	WASHER 3.7X8X1	ヒラサ' ガ' ネ 3.7X8X1	1
20		107-29606	PRESSER LIFT CAM	オサエアケ' カム	1
21		107-29952	THREAD LOOSENING ARM ASM.	イトユルメウテ' (クミ)	1
22		SM-6061210-SC	SCREW M6 L=12	ヒラコネシ' M6 L=12	(1)
23		107-30109	KNEE LIFT ARM A	ヒサ' アケ' ウテ' A	1
24		SM-6061202-TP	SCREW M6 L=12	ロツカクアナホ' ルト M6 L=12	1
25		CS-1201011-SH	THRUST COLLAR D=12 W=10	スラストウケ D=12 W=10	1
26		SS-8660610-TP	SCREW 1/4-40 L=6	トメネシ' 1/4-40 L=6	2
27		107-55502	KNEE LIFTER SPRING	ヒサ' アケ' ハ' ネ	1
28		PS-0500452-KP	SPRING PIN	スワ' リソク' ピ' ン	1
29		107-30703	KNEE SIDE SHAFT HOLDER	ヒサ' アテヨコシ' クウケ	1
30		SM-9081050-SE	SCREW	ロツカクホ' ルト	2
31		107-36908	PRESSER LIFT LEVER	オサエアケ' テコ	1
32		PA-4002002-00	AIR CYLINDER	エアシリンダ'	1
33		PJ-3010651-04	HALF UNION	ストレ-ト	2
34		SM-1082501-SE	SCREW M8 L=25	サラネシ' M8 L=25	4
35		107-37013	CYLINDER CONNECTION SCREW	シリンダ' -レンケツネシ'	1
36		SD-0720331-SP	HINGE SCREW D= 7.24 H= 3.3	タ'ンネシ' D=7.24 H=3.3	1
37		NM-6080001-SE	NUT M8	ロツカクナツト M8 1シユ	1
38		HX-0029500-0B	WIRE MARK(3)	ワイヤ-マ-ク(3)	1
39		HX-0029500-0A	WIRE MARK(2)	ワイヤ-マ-ク(2)	1
40		121-09500	BUSHING, REAR	ハリクト' ウシ' ク ウシロメタル	1

# 15. LUBRICATION COMPONENTS

給油関係

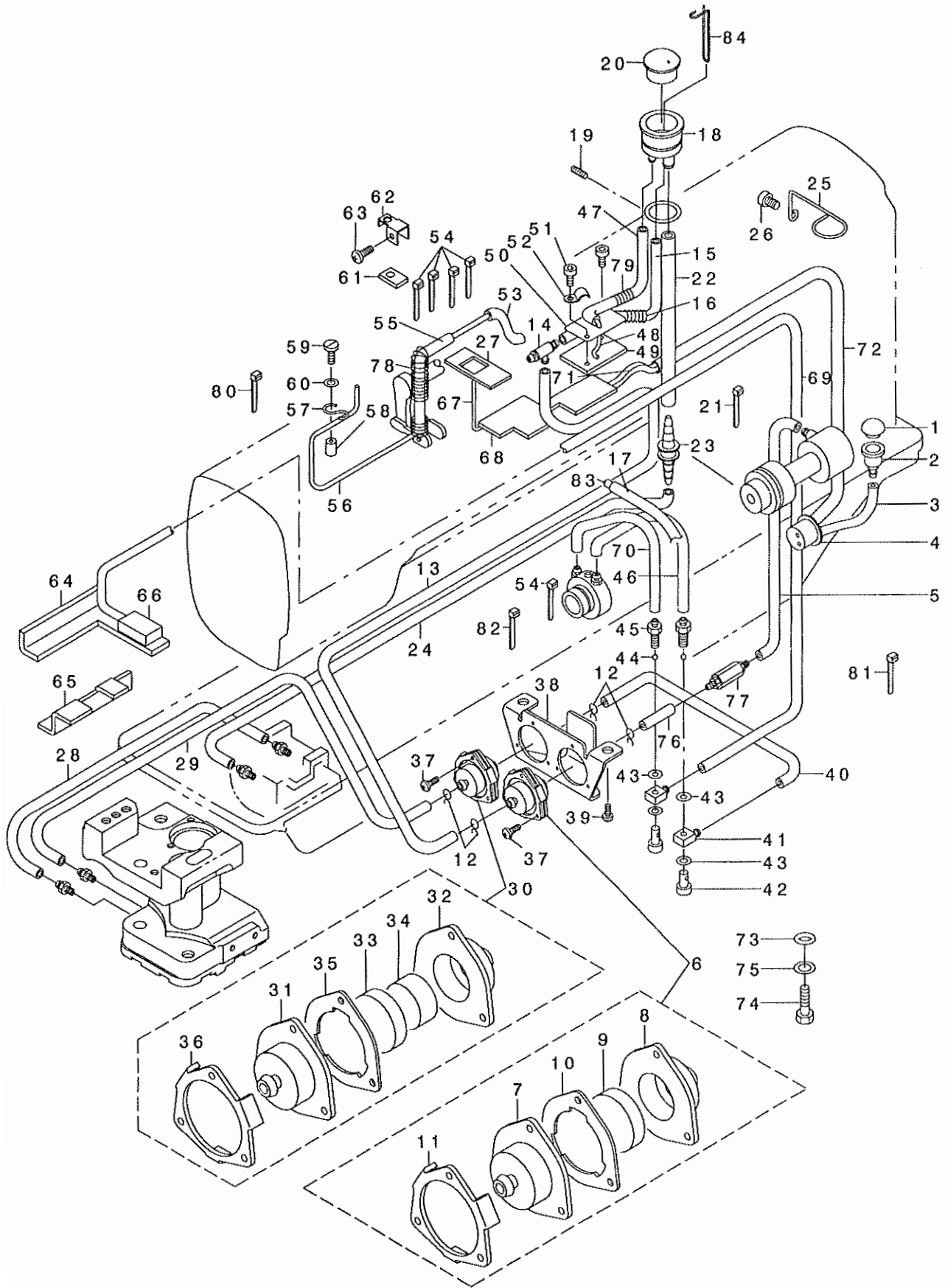

REF. NO	NOTE	PART NO.	DESCRIPTION	キ ャ ン ン	Qty
1		TA-1450404-RO	RUBBER PLUG D=14.5 L=4	トメ栓 D=14.5 L=4	1
2		107-31404	LUBRICATING HOLE	キョウユクチ	1
3		BT-0600402-EA	OIL TUBE	チューブ	0.2
4		107-33004	BED TANK LUBRICATING COVER	ﾊﾞｯﾄﾞ ﾀﾝｸｷｬﾌﾞﾙﾀ	1
5		BT-0500300-E0	OIL TUBE	ｸﾞﾚﾀﾝ ﾉｰﾌﾞ D=3X5	0.25
6		107-27154	FILTER A ASW.	ﾌｲﾙﾀｰA(ｸﾞﾐ)	1
7		107-27105	FILTER CASE	ﾌｲﾙﾀｰ-ｸﾞｰｽ	(1)
8		107-27204	FILTER CAP	ﾌｲﾙﾀｰ-ｷｬｯﾌﾟ	(1)
9		B8228-125-000	OIL RESERVOIR MAGNET	ｼﾞ ﾉﾞｸ	(1)
10		107-39209	FILTER PACKING	ﾌｲﾙﾀｰ-ﾊﾞ ﾉﾞｷﾝ	(1)
11		107-53002	FILTER PLATE	ﾌｲﾙﾀｰ-ﾌﾟﾚｰﾄ	(1)
12		101-26803	OIL TUBE HOLDER	ﾊﾞ ﾉﾞ ﾉﾞ ﾉ	4
13		BT-0500300-E0	OIL TUBE	ｸﾞﾚﾀﾝ ﾉｰﾌﾞ D=3X5	0.6
14		B3521-245-000	RUBBER JOINT	ﾀﾞ ﾉﾞ ﾉ ﾉ ﾉ	1
15		BT-0500300-E0	OIL TUBE	ｸﾞﾚﾀﾝ ﾉｰﾌﾞ D=3X5	0.2
16		B3520-245-000	SPRING	ﾊﾞ ﾉ	1
17		BT-0800602-E0	URETHANE TUBE 6X8 TRANSPARENT	ｸﾞﾚﾀﾝ ﾉｰﾌﾞ 6X8 ﾉ ﾉ ﾉ	0.14
18		107-71509	OIL WINDOW	ﾌﾞ ﾉ ﾉ ﾉ ﾉ ﾉ ﾉ ﾉ	1
19		SS-8150750-SP	SCREW 15/64-28 L=7	ﾄﾞﾚｽ ﾉ 15/64-28 L=7	1
20		107-60304	OIL SIGHT WINDOW	ﾌﾞ ﾉ ﾉ ﾉ ﾉ ﾉ ﾉ ﾉ	1
21		EA-9500800-00	CLIP CV-70S	ｸﾞ ﾉ ﾉ ﾉ ﾉ ﾉ ﾉ ﾉ 60	3
22		BT-0800602-E0	URETHANE TUBE 6X8 TRANSPARENT	ｸﾞﾚﾀﾝ ﾉｰﾌﾞ 6X8 ﾉ ﾉ ﾉ	0.17
23		107-71301	PIPE CONNECTOR B	ﾊﾞ ﾉ ﾉ ﾉ ﾉ ﾉ ﾉ ﾉ	1
24		BT-0600402-EA	OIL TUBE	チューブ	0.83
25		231-51509	CORD GUIDE	ｺｰﾄﾞ ﾉ ﾉ ﾉ ﾉ	1
26		SS-6121010-SP	SCREW 3/16-28 L=10	ﾄﾞﾚｽ ﾉ 3/16-28 L=10	1
27		107-47111	LUBRICATING FELT	ｸﾞ ﾉ ﾉ ﾉ ﾉ ﾉ ﾉ ﾉ ﾉ ﾉ ﾉ ﾉ ﾉ ﾉ ﾉ	1
28	#01	BT-0600402-EA	OIL TUBE	チューブ	0.18
29	#01	BT-0500300-E0	OIL TUBE	ｸﾞﾚﾀﾝ ﾉｰﾌﾞ D=3X5	0.64
30		107-27162	FILTER B ASW.	ﾌｲﾙﾀｰB(ｸﾞﾐ)	1
31		107-27105	FILTER CASE	ﾌｲﾙﾀｰ-ｸﾞｰｽ	(1)
32		107-27204	FILTER CAP	ﾌｲﾙﾀｰ-ｷｬｯﾌﾟ	(1)
33		B8228-125-000	OIL RESERVOIR MAGNET	ｼﾞ ﾉﾞｸ	(1)
34		107-27303	FILTER	ﾌｲﾙﾀｰ	(1)
35		107-39209	FILTER PACKING	ﾌｲﾙﾀｰ-ﾊﾞ ﾉﾞｷﾝ	(1)
36		107-53002	FILTER PLATE	ﾌｲﾙﾀｰ-ﾌﾟﾚｰﾄ	(1)
37		SM-4020801-SD	SCREW M2 L=8	ﾄﾞ ﾉ ﾉ ﾉ ﾉ M2 L=8	6
38		107-55403	FILTER FIXING PLATE	ﾌｲﾙﾀｰ-ｺﾞ ﾉ ﾉ ﾉ ﾉ	1
39		SM-6061210-SC	SCREW M6 L=12	ﾄﾞ ﾉ ﾉ ﾉ ﾉ M6 L=12	2
40		BT-0500300-E0	OIL TUBE	ｸﾞﾚﾀﾝ ﾉｰﾌﾞ D=3X5	0.1
41		SQ-0000401-MZ	CONNECTING SCREW	ﾉｰﾌﾞ ﾉ ﾉ ﾉ ﾉ ﾉ ﾉ ﾉ	2
42		B3525-357-000	CONNECTING SCREW (B)	ﻟ ﾉ ﾉ ﾉ ﾉ ﾉ ﾉ ﾉ ﾉ ﾉ ﾉ ﾉ ﾉ ﾉ	2
43		B3534-012-000	GASKET	ﾊﾞ ﾉ ﾉ ﾉ	4
44		210-54903	BALL	ﾓ ﾉ ﾉ ﾉ ﾉ ﾉ ﾉ ﾉ ﾉ ﾉ ﾉ ﾉ ﾉ ﾉ ﾉ	2
45		107-02108	CONNECTING SCREW	ﾊﾞ ﾉ ﾉ ﾉ ﾉ ﾉ ﾉ ﾉ ﾉ ﾉ ﾉ ﾉ ﾉ ﾉ	2
46		BT-0500300-E0	OIL TUBE	ｸﾞﾚﾀﾝ ﾉｰﾌﾞ D=3X5	0.13
47		BT-0600402-EA	OIL TUBE	チューブ	0.66
48		CQ-2520000-00	OIL WICK	ﾓ ﾉ ﾉ ﾉ	0.93
49		107-32402	VERTICAL LUBRICATING FELT	ｸﾞ ﾉ ﾉ ﾉ ﾉ ﾉ ﾉ ﾉ ﾉ ﾉ ﾉ ﾉ ﾉ ﾉ ﾉ	1
50		107-32600	LUBRICATING FELT PRESSER B	ｷｬ ﾉ ﾉ ﾉ ﾉ ﾉ ﾉ ﾉ ﾉ ﾉ ﾉ ﾉ ﾉ ﾉ ﾉ	1
51		SM-6050802-TP	SCREW M5X0.8 L=8	ﾄﾞ ﾉ ﾉ ﾉ ﾉ ﾉ ﾉ ﾉ ﾉ ﾉ ﾉ ﾉ ﾉ ﾉ	1
52		D2611-555-B00-A	CABLE HOLDER	ｸﾞｰﾌﾞ ﾉ ﾉ ﾉ ﾉ ﾉ ﾉ ﾉ	1
53		BT-0600402-EA	OIL TUBE	チューブ	0.4
54		EA-9500801-00	CABLE BAND	ｼﾞ ﾉ ﾉ ﾉ ﾉ ﾉ ﾉ ﾉ	11
55		BT-0400251-EA	TUBE HOSE, BLUE	ｸﾞ ﾉ ﾉ ﾉ ﾉ ﾉ ﾉ ﾉ ﾉ ﾉ ﾉ ﾉ ﾉ ﾉ	0.16
56		CQ-2020000-00	OIL WICK	ﾓ ﾉ ﾉ ﾉ	0.8
57		B1648-122-000	SUSPENSION HOOK (B)	ﾋ ﾉ ﾉ ﾉ ﾉ ﾉ ﾉ ﾉ ﾉ ﾉ ﾉ ﾉ ﾉ ﾉ	1
58		107-34606	FELT PRESSER SPACER	ｸﾞ ﾉ ﾉ ﾉ ﾉ ﾉ ﾉ ﾉ ﾉ ﾉ ﾉ ﾉ ﾉ ﾉ ﾉ	1
59		SS-6081210-SP	SCREW 1/8-44 L=12	ﾄﾞ ﾉ ﾉ ﾉ ﾉ 1/8-44 L=12	1
60		WP-0320501-SC	WASHER M3	ﾄﾞ ﾉ ﾉ ﾉ ﾉ ﾉ ﾉ ﾉ ﾉ ﾉ ﾉ ﾉ ﾉ ﾉ	1
61		107-33608	SWING STAND FELT, UPPER	ｼ ﾉ ﾉ ﾉ ﾉ ﾉ ﾉ ﾉ ﾉ ﾉ ﾉ ﾉ ﾉ ﾉ ﾉ	1
62		107-33707	SWING STAND FELT SUPPORT, UPPER	ｼ ﾉ ﾉ ﾉ ﾉ ﾉ ﾉ ﾉ ﾉ ﾉ ﾉ ﾉ ﾉ ﾉ ﾉ	1
63		SM-4040601-SC	SCREW M4X0.7 L=6	ﾄﾞ ﾉ ﾉ ﾉ ﾉ M4X0.7 L=6	1
64		107-34119	RETURN CURRENT FELT	ﾌ ﾉ ﾉ ﾉ ﾉ ﾉ ﾉ ﾉ ﾉ ﾉ ﾉ ﾉ ﾉ ﾉ ﾉ	1
65		107-02207	FELT	ｷ ﾉ ﾉ ﾉ ﾉ ﾉ ﾉ ﾉ ﾉ ﾉ ﾉ ﾉ ﾉ ﾉ ﾉ	1
66		105-27901	FELT	ｷ ﾉ ﾉ ﾉ ﾉ ﾉ ﾉ ﾉ ﾉ ﾉ ﾉ ﾉ ﾉ ﾉ ﾉ	1
67		CQ-2020000-00	OIL WICK	ﾓ ﾉ ﾉ ﾉ	0.25
68		107-34309	FELT	ﾌ ﾉ ﾉ ﾉ ﾉ ﾉ ﾉ ﾉ ﾉ ﾉ ﾉ ﾉ ﾉ ﾉ ﾉ	1
69		BT-0500300-E0	OIL TUBE	ｸﾞﾚﾀﾝ ﾉｰﾌﾞ D=3X5	1.06
70		BT-0500300-E0	OIL TUBE	ｸﾞﾚﾀﾝ ﾉｰﾌﾞ D=3X5	0.13
71		Z11-24202			1
72		BT-0800602-E0	URETHANE TUBE 6X8 TRANSPARENT	ｸﾞﾚﾀﾝ ﾉｰﾌﾞ 6X8 ﾉ ﾉ ﾉ	0.78
73		RO-0681901-00	RUBBER RING	ﾓ ﾉ ﾉ ﾉ ﾉ	1
74		SM-9081050-SE	SCREW	ﾄﾞ ﾉ ﾉ ﾉ ﾉ ﾉ ﾉ ﾉ ﾉ ﾉ ﾉ ﾉ ﾉ ﾉ	1
75		WP-0841601-SC	WASHER 8.4X17.4X1.6	ﾄﾞ ﾉ ﾉ ﾉ ﾉ ﾉ ﾉ ﾉ ﾉ ﾉ ﾉ ﾉ ﾉ ﾉ	1
76		BT-0500300-E0	OIL TUBE	ｸﾞﾚﾀﾝ ﾉｰﾌﾞ D=3X5	0.05
77		231-59254	CHECK VALVE	ｷ ﾉ ﾉ ﾉ ﾉ ﾉ ﾉ ﾉ ﾉ ﾉ ﾉ ﾉ ﾉ ﾉ ﾉ	1
78		107-46907	SPRING	ﾊﾞ ﾉ ﾉ ﾉ ﾉ ﾉ ﾉ ﾉ ﾉ ﾉ ﾉ ﾉ ﾉ ﾉ	1
79		101-23701	PRESSER SPRING	ﾄ ﾉ ﾉ ﾉ ﾉ ﾉ ﾉ ﾉ ﾉ ﾉ ﾉ ﾉ ﾉ ﾉ ﾉ	1
80		EA-9500800-00	CLIP CV-70S	ｸﾞ ﾉ ﾉ ﾉ ﾉ ﾉ ﾉ ﾉ ﾉ ﾉ ﾉ ﾉ ﾉ ﾉ ﾉ	1
81		EA-9500802-00	CABLE BAND 150	ｸﾞ ﾉ ﾉ ﾉ ﾉ ﾉ ﾉ ﾉ ﾉ ﾉ ﾉ ﾉ ﾉ ﾉ ﾉ	2
82	#01	EA-9500801-00	CABLE BAND	ｼﾞ ﾉ ﾉ ﾉ ﾉ ﾉ ﾉ ﾉ ﾉ	1
83		SQ-1680701-MZ	CONNECTING SCREW	ﾉｰﾌﾞ ﾉ ﾉ ﾉ ﾉ ﾉ ﾉ ﾉ ﾉ	1
84		107-60502	LUBRICATION GUIDE BAR	ｷ ﾉ ﾉ ﾉ ﾉ ﾉ ﾉ ﾉ ﾉ ﾉ ﾉ ﾉ ﾉ ﾉ ﾉ	1
		NOTE (注記)	#01...FOR LU-2266N-7	LU-2266N-7用	

# 16. CONTROL DEVICE COMPONENTS

## 制御装置関係

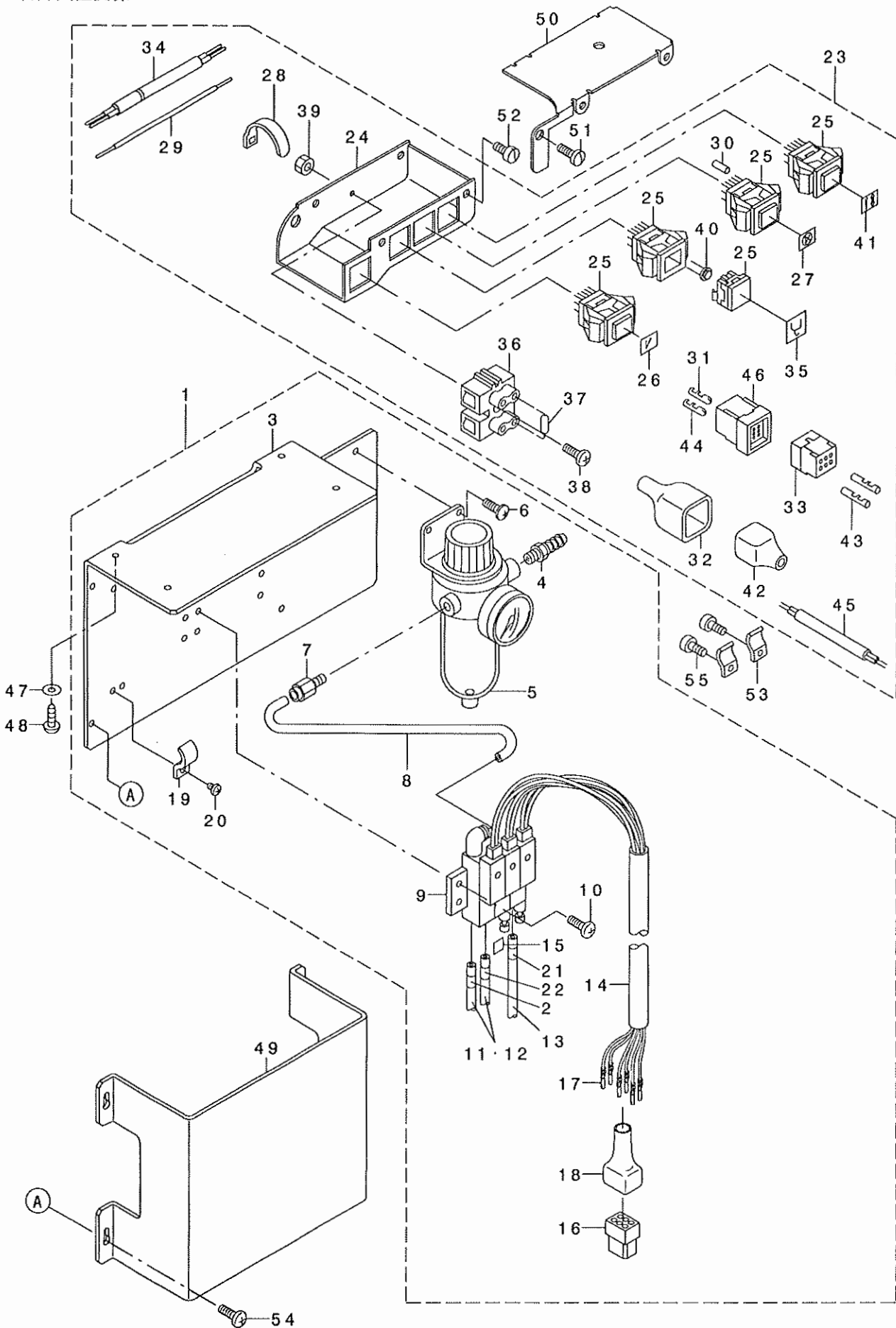



REF. NO	NOTE	PART NO.	DESCRIPTION	品名	Qty
1		GAK-79001AAO	CONTROL MACHINE A ASM.(4TYPE)	セイキ ヨソウチAクミ(4タイプ)	1
2		HX-0029500-OB	WIRE MARK(3)	ワイヤマーク(3)	(3)
3		107-37104	MAGNETIC FITTING PLATE	デノシハントリツケイタ	(1)
4		PJ-0325160-01	NIPPLE	ホスニツブル	(1)
5		PF-0551030-AO	FILTER REGULATOR	フィルタレキユレータ	(1)
6		SM-0050801-SC	SCREW	トラスネジ M5 L=8	(2)
7		PJ-3010851-02	JOINTING	ストレート	(1)
8		BT-0800501-EB	VINYL TUBE	チューブ	(1)
9		PV-0399010-AO	STACKING MANIFOLD VALVE	スタッキング マニホールド デノシハント	(1)
10		SM-4052501-SC	SCREW M5X0.8 L=25	ナハコネジ M5X0.8 L=25	(4)
11		BT-0600401-EB	TUBE	チューブ	(1)
12		BT-0600401-EB	TUBE	チューブ	(1)
13		BT-0600401-EB	TUBE	チューブ	(1.1)
14		GAK-A1503000	INSULATION TUBE	セツエンチューブ	(0.8)
15		HX-0029500-OC	WIRE MARK(4)	ワイヤマーク(4)	(1)
16		D6029-555-BOA	NYLON PLUG 6P	6P ナイロンプラグ	(1)
17		D6043-555-B00	PIN TERMINAL, MALE	ピンターミナル オス	(6)
18		HK-0045900-0A	6-POLE NYLON PLUG COVER	プラグカバー - 6P クロ	(1)
19		D2611-555-B00-A	CABLE HOLDER	ケーブルホルダ	(1)
20		SM-4040601-SN	SCREW M4 L=6	ナハコネジ M4X0.7 L=6	(1)
21		HX-0029500-00	WIRE MARK(1)	ワイヤマーク(1)	(3)
22		HX-0029500-0A	WIRE MARK(2)	ワイヤマーク(2)	(3)
23		231-52150	TOUCH BACK SWITCH ASM.(E)	タッチバックスイッチクミ(E)	1
24		107-40611	TOUCH BACK SWITCH BASE	タッチバックスイッチトリツケタ	(1)
25		107-48507	TOUCH BACK SWITCH	タッチバックスイッチ	(4)
26		107-48804	PANEL SHEET A	パネルシートA	(1)
27		107-49109	PANEL SHEET C	パネルシートC	(1)
28		EA-9500B01-00	CABLE BAND	ソクセンバンド	(1)
29		HW-2002500-00	WIRE, BLACK		(0.4)
30		E8760-452-D00	TUBE 0.015M	スミチューブ	(0.2)
31		HK-0039300-00	PIN-SHAPE TERMINAL, MALE	ピンターミナル オス	(1)
32		M9637-110-000	12-POLE PLUG COVER	プラグカバー - 12P	(1)
33		HK-0174200-60	6P RECEPTACLE	ハウジング 6P	(1)
34		HW-0008400-80	4-CORE CABTYRE CORD	ケーブル 8芯	(1.9)
35		107-48903	PANEL SHEET B	パネルシートB	(1)
36		107-41908	2-P TERMINAL BASE	タンジタ	(1)
37		HR-0291015-20	RESISTOR 1.5K	テイクウキ 1.5K	(1)
38		SM-4861201-SC	SCREW M2.6 L=12	ナハコネジ M2.6 L=12	(1)
39		NM-6860003-SC	NUT M2.6	ワツカクナツト M2.6 3ツユ	(1)
40		107-40801	LED CORD	LED(ミトリ)	(1)
41		107-52707	PANEL SHEET E	パネルシートE	(1)
42		HK-0045900-0A	6-POLE NYLON PLUG COVER	プラグカバー - 6P クロ	(1)
43		D6042-555-B00	PIN TERMINAL, FEMALE	ピンターミナル メス	(6)
44		D6043-555-B00	PIN TERMINAL, MALE	ピンターミナル オス	(11)
45		HW-5001800-00	CABTYRE CORD ASM. 6P	キャブタイヤコード 6P クミ	(0.2)
46		M9640-110-000	12-POLE PLUG	ナイロンプラグ 12P	(1)
47		WP-0501016-SC	WASHER 5X10.5X1	ヒラサガネ 5X10.5X1	4
48		SK-3482500-SC	WOOD SCREW D=4.8 L=25	マルモクネジ D=4.8 L=25	4
49		107-37203	MAGNETIC FITTING PLATE COVER	デノシハントリツケイタカバー	1
50		107-40710	TOUCH BACK SWITCH COVER	タッチバックスイッチカバー	1
51		SS-7120710-SP	SCREW 3/16-28 L=7	マルヒラネジ 3/16-28 L=7	2
52		SS-6110610-TP	SCREW 11/64-40 L=6	ヒラネジ 11/64-40 L=6	4
53		D2611-555-B00-A	CABLE HOLDER	ケーブルホルダ	5
54		SM-4051001-SC	SCREW M5 L=10	ナハコネジ M5X0.8 L=10	4
55		SS-6121010-SP	SCREW 3/16-28 L=10	ヒラネジ 3/16-28 L=10	2

# 17. TABLE & BELT COVER COMPONENTS

テーブル・ベルトカバー関係

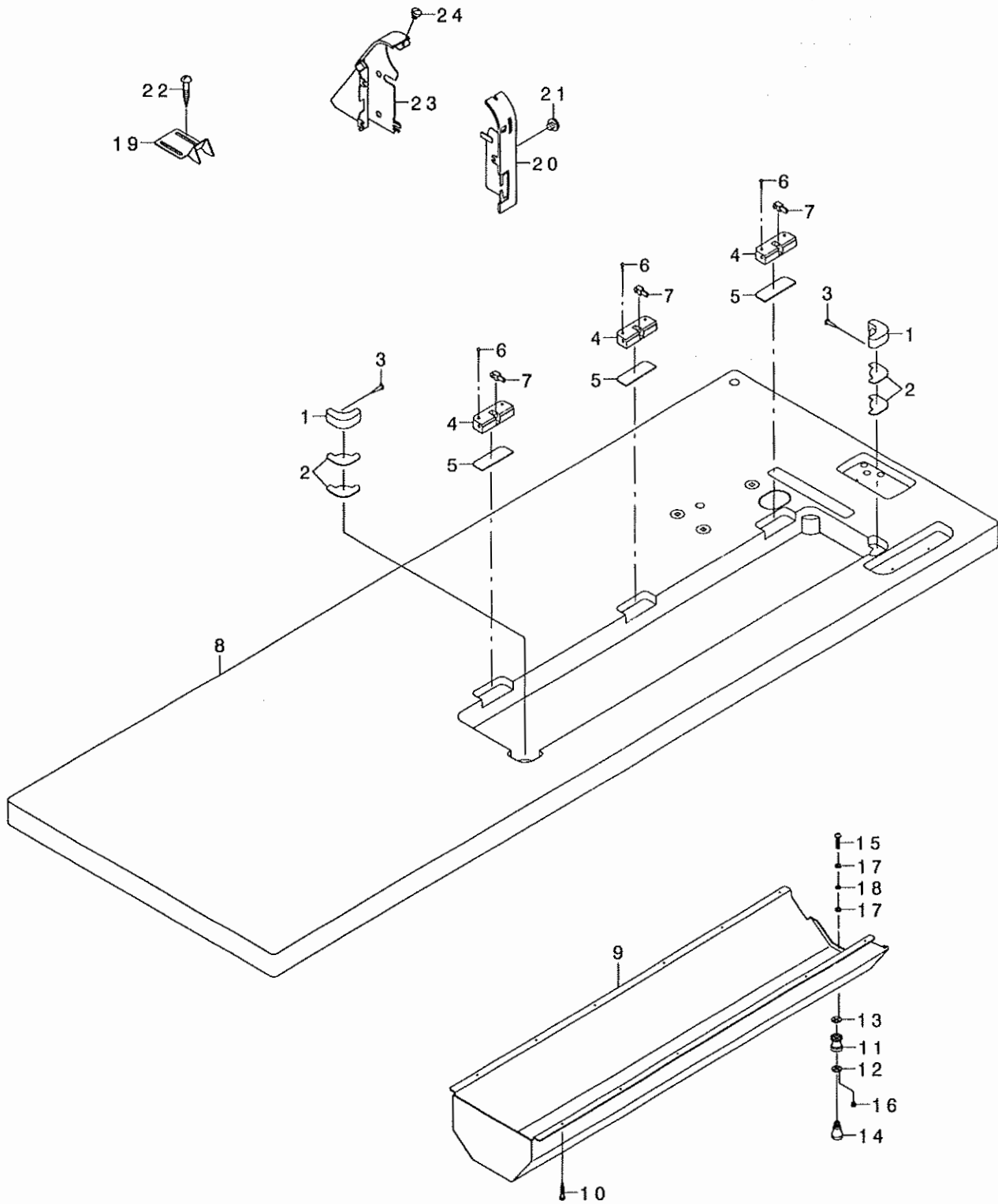

REF. NO	NOTE	PART NO.	DESCRIPTION	ヒョウメイ	Qty
1		107-42302	HEAD SUPPORT RUBBER	トウブ' ササエゴ' A	2
2		107-40900	RUBBER	ホ' ウシンゴ' A	4
3		105-39906	SET NAIL	トメクキ'	4
4		107-34853	HINGE ASM.	ヒンヂ' サ' (クミ)	3
5		107-42005	SPACER	スハ' -サ-ゴ' A	3
6		105-39906	SET NAIL	トメクキ'	6
7		B8213-012-000	BED HINGE CONNECTION	ヒンヂ' シ' ク	3
8		231-58207	TABLE (LONG BED)	テ-プ' ル(ロンク' ハ' ット')	1
9		231-51202	OIL HOLDER (LONG)	アブ' ラウク(ロンク')	1
10		SK-3241601-SC	WOOD SCREW D=2.4 L=16	マルモクネシ' D=2.4 L=16	11
11		B8202-205-000	OIL MANAGEMENT	アブ' ラヌキ	1
12		B8111-220-000	WASHER	アブ' ラヌキ サ' カ' ネ	1
13		B8112-220-000	OIL SEAL	アブ' ラヌキ オイルシ-ル	1
14		B9121-012-000	OIL CAN	アブ' ラヒ' ッ	1
15		SM-3031401-SE	SCREW M3X0.5 L=14	マルコネシ' M3X0.5 L=14	4
16		NM-6030001-SC	NUT M3	ロツカクナツト M3X0.5 1シユ	4
17		107-48101	OIL REMOVING SETSCREW PACKING	アブ' ラヌキトメネシ' ハ' ッキシ	8
18		WP-0320501-SC	WASHER M3	ヒラサ' カ' ネ 3.2X7X0.5	4
19	#01	107-55205	BELT COVER C(JE)	ハ' ルトカハ' -C(JE)ヨウ	1
20	#01	107-55155	BELT COVER, LEFT(JE)	ハ' ルトカハ' -ヒタ' リ(JE)ラハ' ルツキ	1
21		SS-5150510-SP	SCREW 15/64-28 L=5	トラスネシ' 15/64-28 L=5	3
22	#01	SK-3482500-SC	WOOD SCREW D=4.8 L=25	マルモクネシ' D=4.8 L=25	2
23	#01	107-55007	BELT COVER, RIGHT	ハ' ルトカハ' -ミキ' (JE)ヨウ	1
24		SS-7110510-SP	SCREW 11/64-40 L=5	マルヒラネシ' 11/64-40 L= 5	1
		NOTE (注記)	#01...FOR JE	JE用	

# 18. THREAD STAND COMPONENTS

糸立て装置関係

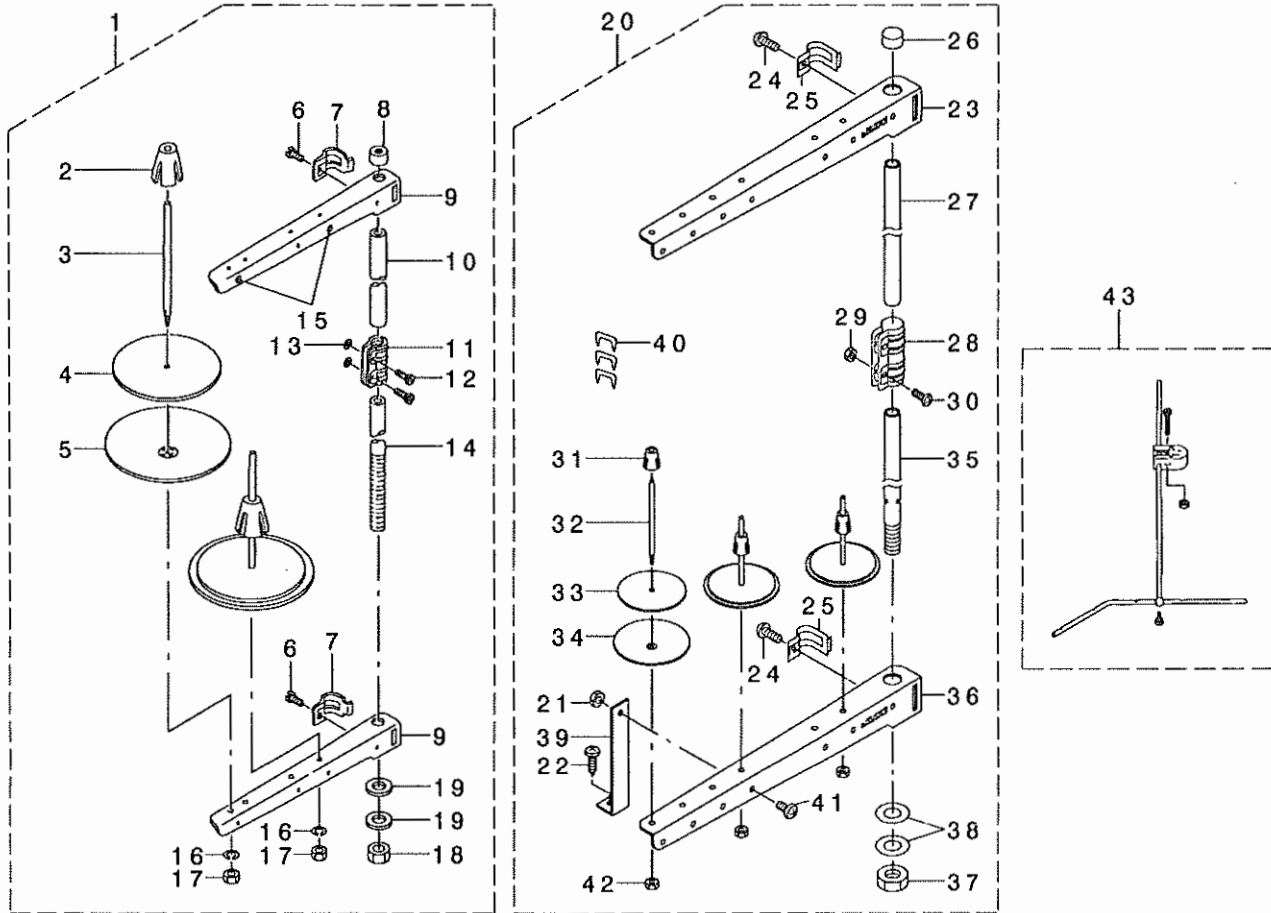

REF. NO	NOTE	PART NO.	DESCRIPTION	ヒョウメイ	Qty
1		229-30358	THREAD STAND ASM.	糸立て装置(クミ)	1
2		229-31109	SPOOL RETAINER	糸巻きホルトメ	(2)
3		229-31090	SPOOL PIN	糸巻き針	(2)
4		229-30903	SPOOL REST CUSHION	糸巻き針サシクッション	(2)
5		229-30804	SPOOL REST	糸巻き針サシ	(2)
6		SM-6061610-SC	SCREW M6 L=16	ビスM6 L=16	(2)
7		229-30705	THREAD GUIDE ARM JOINT	糸立てアームジョイント	(2)
8		229-31406	SPOOL REST ROD RUBBER CAP	糸立て針ホルダゴム	(1)
9		229-30507	SPOOL REST ARM	糸立てアーム	(2)
10		229-30408	SPOOL REST ROD, UPPER	糸立て針ウ(ウエ)	(1)
11		229-31307	SPOOL REST ROD JOINT	糸立て針ジョイント	(1)
12		SM-4051405-SE	SCREW M5 L=14	ナット M5 L=14	(2)
13		NM-6050001-SE	NUT M5	ワッシャー M5	(2)
14		229-30309	SPOOL REST ROD, LOWER	糸立て針(ウタ)	(1)
15		229-31208	THREAD GUIDE	糸ミチ	(2)
16		WS-0510002-KN	SPRING WASHER	スプリングワッシャー 5.1X9.2X1.3	(2)
17		NM-6050001-SE	NUT M5	ワッシャー M5	(2)
18		NM-6160511-SE	NUT M16X1.5	ワッシャー M16X1.5 132	(1)
19		WP-1702600-S0	WASHER 17X30X2.6	ワッシャー 17X30X2.6	(2)
20	#01	D3301-772-TAB	THREAD STAND ASM.	糸立て装置 クミ	1
21		NM-6060001-SE	NUT M6	ワッシャー M6 132	(1)
22		SK-3382001-SE	SCREW D=3.8 L=20	ビス D=3.8 L=20	(1)
23		B3319-704-LOO	THREAD GUIDE	糸ミチ	(3)
24		SM-6061610-SC	SCREW M6 L=16	ビス M6 L=16	(2)
25		B3318-704-LOO-A	THREAD GUIDE ARM JOINT	糸立てアームジョイント	(2)
26		B3311-704-000	SPOOL REST ROD CAP	糸立て針ホルダ	(1)
27		111-85204	SPOOL REST ROD, UPPER	糸立て針ウ(ウエ)	(1)
28		B3305-704-000-A	SPOOL REST ROD JOINT	糸立て針ジョイント	(1)
29		NM-6050001-SE	NUT M5	ワッシャー M5	(2)
30		SM-4051405-SE	SCREW M5 L=14	ナット M5 L=14	(2)
31		111-85501	SPOOL RETAINER	糸巻きホルトメ	(3)
32		B3320-704-LOO-A	SPOOL PIN	糸巻き針	(3)
33		B3311-012-000	SPOOL REST CUSHION	糸巻き針サシクッション	(3)
34		119-66504	SPOOL REST	糸巻き針サシ	(3)
35		111-85105	SPOOL REST ROD, LOWER	糸立て針ウ(ウタ)	(1)
36		119-69508	SPOOL REST ARM A	糸立てアーム A	(2)
37		B3317-704-000	NUT	糸立て針ホルダ	(1)
38		WP-1612616-SE	WASHER 16X30X2.6	ワッシャー 16X30X2.6	(2)
39		B3321-704-LOO	SPOOL REST ARM SUPPORT, A	糸立てアームサポーター A	(1)
40		MAO-11532000	CORD STAPLE	コードスタプレ	(3)
41		SM-4061201-SE	SCREW M6 L=12	ナット M6 L=12	(1)
42		NM-6050001-SE	NUT M5	ワッシャー M5	(3)
43		B3309-704-OAO	THREAD GUIDE ARM ASM.	糸立てアームジョイント クミ	1

NOTE (注記)

#01... FOR LU-2266N-7

LU-2266N-7用

19. GAUGE COMPONENTS(LU-2216N-7 STANDARD PARTS)

ゲージ関係 (LU-2216N-7 標準品)

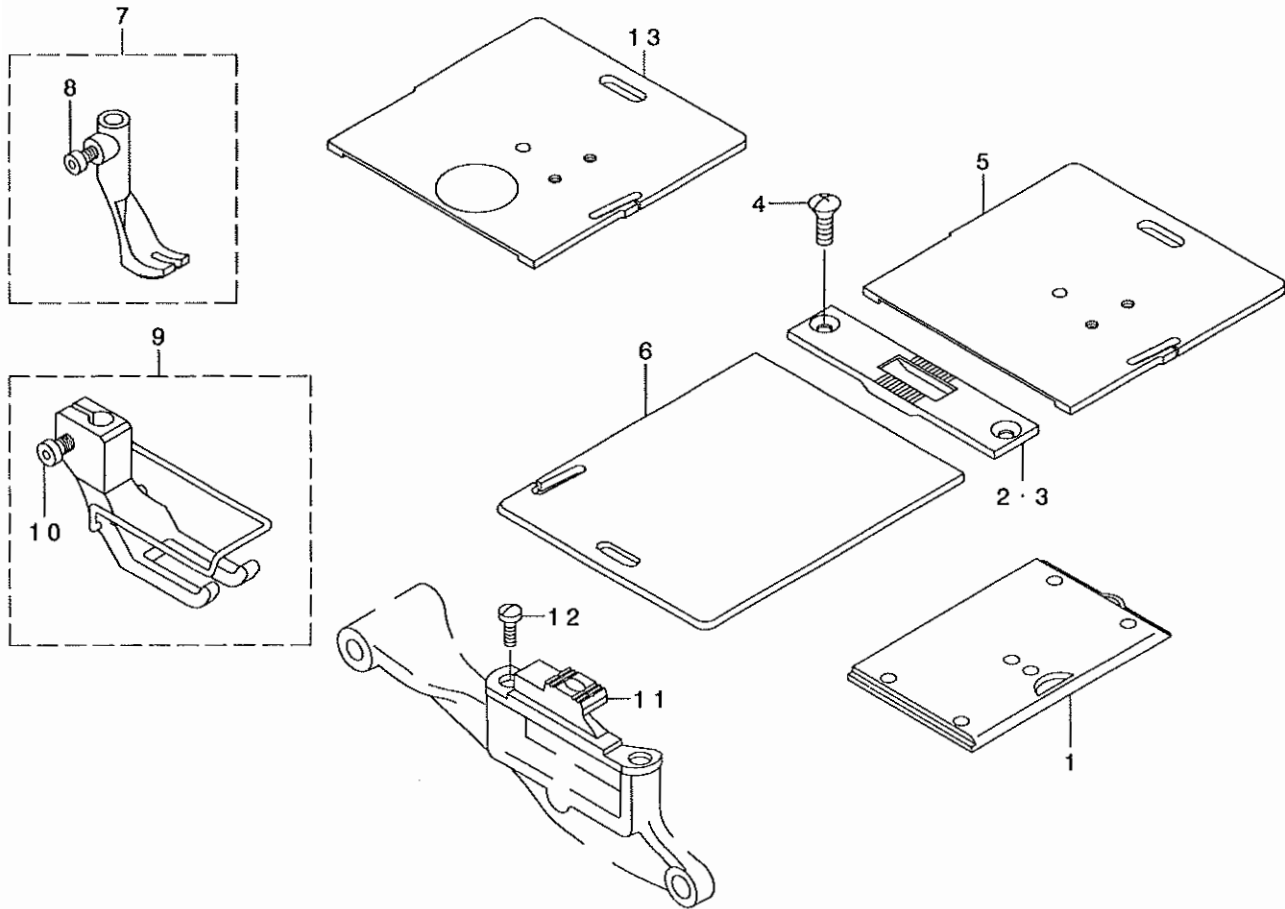

REF. NO	NOTE	PART NO.	DESCRIPTION	ヒョウメイ	Qty
1		107-01654	SLIDE PLATE ASM.	スハ'リイタ クミ	1
2		107-01704	THROAT PLATE	ハリイタ	1
3	#01	107-02009	THROAT PLATE	ハリイタ(ハハ'ヒロ)	1
4		SS-2110915-SP	SCREW 11/64-40 L=8.5	マルサラネシ' 11/64-40 L=8.5	2
5		107-01803	SLIDE PLATE ,RIGHT	イトキリスハ'リイタ(ミキ')	1
6		107-01902	SLIDE PLATE ,LEFT	イトキリスハ'リイタ(ヒタ'リ)	1
7		107-11653	FEED FOOT ASM.	オクリアシ(クミ)	1
8		SM-6040552-TP	SCREW M4 L=4.5	ロツカクアナホ' ネト M4 L=4.5	(1)
9		107-12552	PRESSER FOOT ASM.	オサエアシ クミ	1
10		SM-6040802-TP	SCREW M4X0.7 L=8	ロツカクアナホ' ネト	(1)
11		107-17106	FEED DOG	オクリハ'	1
12		SS-6111010-SP	SCREW 11/64-40 L= 9.5	ヒラネシ' 11/64-40 L=9.5	2
13	#01	107-53150	SLIDER PLATE ASM., RIGHT	イトキリスハ'リイタ(ミキ')マト'ツキクミ	1
		NOTE (注記)	#01....OPTIONAL PARTS	オプ'ション部品	

20. GAUGE COMPONENTS(LU-2266N-7 STANDARD PARTS)

ゲージ関係 (LU-2266N-7 標準品)

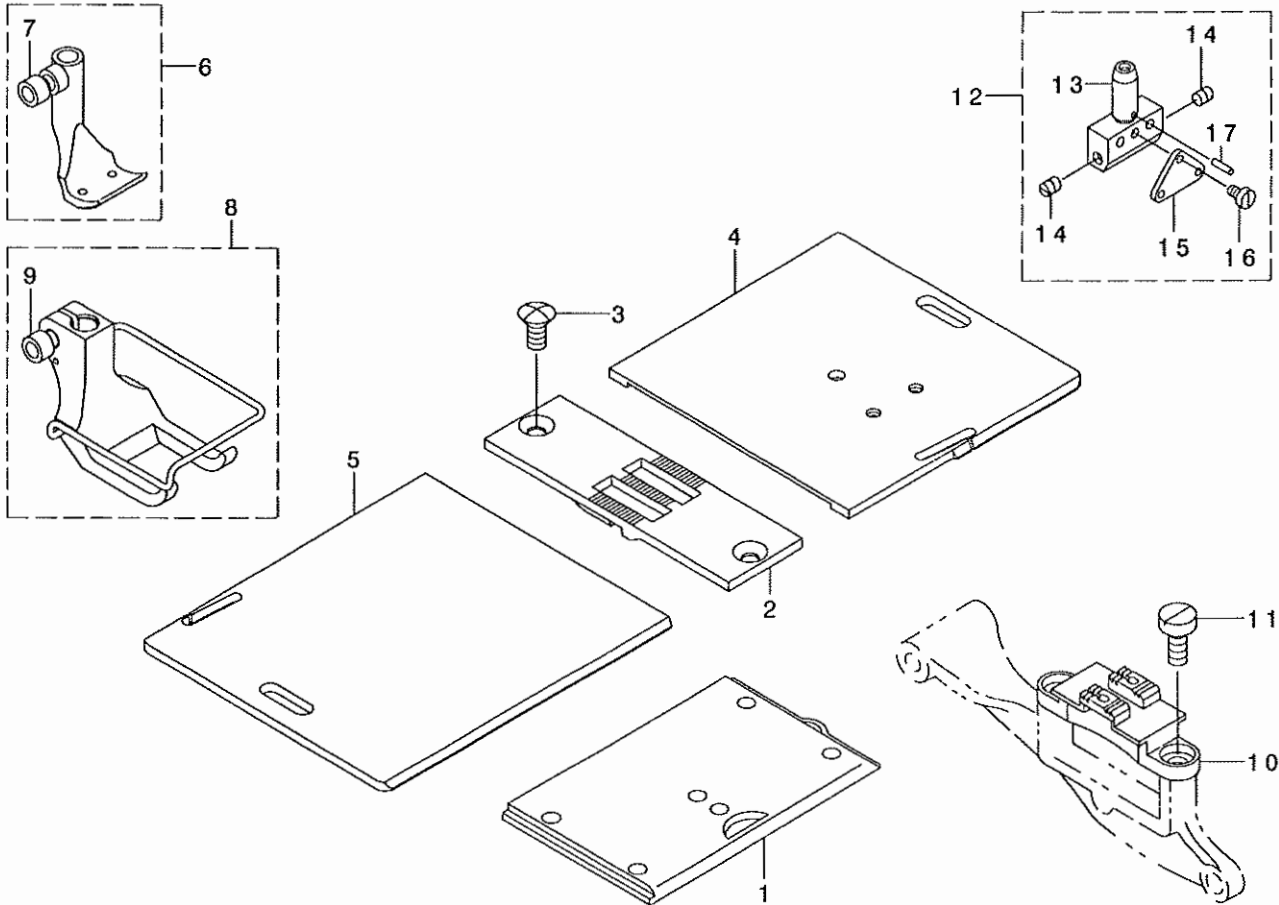

REF. NO	NOTE	PART NO.	DESCRIPTION	ト ヲ メ イ	Qty
1		107-01654	SLIDE PLATE ASM.	スハ' リイタ クミ	1
2		107-84809	THROAT PLATE(10MM)	ハリイタ(10MM)	1
3		SS-2110915-SP	SCREW 11/64-40 L=8.5	マルサラネシ' 11/64-40 L=8.5	2
4		107-86002	SLIDE PLATE,RIGHT 10-1 8MM	スハ' リイタ(ミキ')10-1 8MM	1
5		107-86408	SLIDE PLATE,LEFT 10- 18MM	スハ' リイタ(ヒタ' リ)10- 18MM	1
6		107-83355	FEED FOOT ASM. 10MM	オクリアツ(クミ)10MM	1
7		SM-6040552-TP	SCREW M4 L=4.5	ロツカクアナホ' ルト M4 L=4.5	(1)
8		107-81854	PRESSER FOOT ASM.	オサエアツ(クミ)10MM	1
9		SM-6040802-TP	SCREW M4X0.7 L=8	ロツカクアナホ' ルト	(1)
10		107-80302	FEED DOG	オクリハ' (10MM)	1
11		SS-6111010-SP	SCREW 11/64-40 L= 9.5	ヒラネシ' 11/64-40 L=9.5	2
12		107-77852	NEEDLE CLAMP ASM.10MM	ハリト' メ(クミ)10MM	1
13		107-77803	NEEDLE CLAMP 10MM	ハリト' メ(10MM)	(1)
14		SS-8080410-TP	SCREW 1/8-44 L=3.5	トメネシ' 1/8-44 L=3.5	(2)
15		107-79106	NEEDLE BAR THREAD GUIDE PLATE	ハリホ' ウイトカケ(10-18 MM)	(1)
16		SS-6060440-TP	SCREW 3/32-56 L=3.5	ヒラネシ'	(1)
17		PS-0150065-KP	SPRING PIN 1.5X6	スア' リンク' ビ' ン 1.5X6	(1)

# 21. ACCESSORIES PARTS COMPONENTS

## 付属品関係

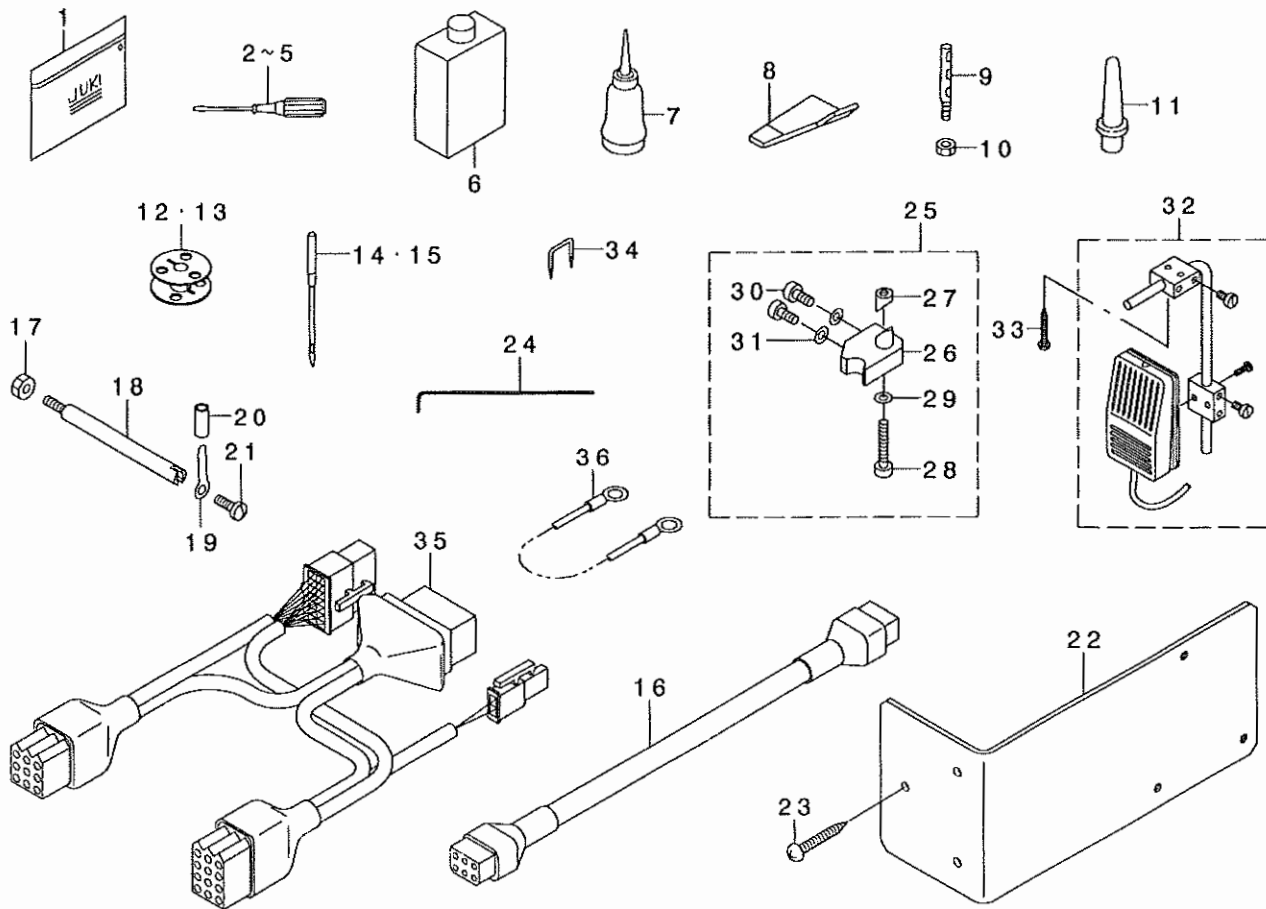

REF. NO	NOTE	PART NO.	DESCRIPTION	ヒョウメイ	Qty
1		B9101-552-000	ACCESSORY BOX	フツクヒンコ	1
2	#03	B9109-555-000	SCREW DRIVER, LARGE	トライナ・グイ	1
3		229-33006	SCREW DRIVER, LARGE	トライナ・(グイ)	1
4		B9111-012-000	SCREW DRIVER, SMALL	トライナ・(コヨ)	1
5		123-47308	SCREW DRIVER (SMALL)	トライナ・(コヨ)	1
6		MDF-RX1600CC	DEFRIX OIL NO.1(600CC)	デフリックス油ノ.1(600CC)	1
7		B9121-012-0A0	OILER ASM.	フツラシクミ	1
8		107-42203	FIXED SURGICAL KNIFE GAUGE	コトイヌケ・ゲ	1
9		B1114-517-000	NEEDLE THREAD GUIDE PIN	イトアソナキ	1
10		NS-6620310-SP	NUT 3/16-32	ロツカクナツト 3/16-32	1
11		110-73103	RUBBER CUSHION	トルク・サシエカク	1
12		107-59603	ALUMINUM BOBBIN (DOUBLE-CUT)	アルミホビン(ロ-レットツキ)	1
13	#01	107-59603	ALUMINUM BOBBIN (DOUBLE-CUT)	アルミホビン(ロ-レットツキ)	2
14		MC-3210014-02	NEEDLE 134-35 #140-2	メシ 134-35 #140-2	1
15	#01	MC-3210014-02	NEEDLE 134-35 #140-2	メシ 134-35 #140-2	2
16	#04	231-58959	PEDAL SENSOR RELAY CABLE ASM.	ペダセンサリヤイカク・メシ	1
17		NS-6150430-SP	NUT 15/64-28	ロツカクナツト 15/64-28	1
18		D7101-245-E00	SYNCHRONIZER HOLDER STUD	クンシユキサシエシク	1
19		D7102-245-E00	SYNCHRONIZER HOLDER PLATE	クンシユキサシエシク	1
20		BT-0630520-Z0	HOLDER COVER	ヒツエンチユ-フ	0.02
21		SS-7110710-SP	SCREW 11/64-40 L=7	マシヒツシツ 11/64-40 L=7	1
22	#04	231-58801	PEDAL SENSOR FITTING PLATE	ペダセンサトツクイ	1
23	#04	SK-3514001-SE	SCREW D=5.1 L=40	マシメクシツ D=5.1 L=40	3
24	#01	107-77407	WRENCH 2.5MM	ロツカクレンフ 2.5MM	1
25	#03	107-35868	FIXING BASE ASM.	ツツシ・ヨウキ・トリツクイ(クミ)	1
26		107-35801	FIXING BASE	ツツシメソトトリツクイ(グイ)	(1)
27		107-37401	FIXING BASE NUT	ツツシメソトトリツクイ(グイ)ナツト	(1)
28		SM-6063502-TP	SCREW M6 L=35	ロツカクナツト	(1)
29		WP-0621016-SD	WASHER 6.2X13X1	ヒツシ・カシ 6.2X13X1	(1)
30		SM-6051602-TP	SCREW M5X0.8 L=16	ロツカクナツト M5X0.8 L=16	(2)
31		WP-0531000-SE	WASHER	ヒツシ・カシ	(2)
32	#02	GAK-A14040C0	KNEE SWITCH A ASM.	サシエケヒツシ・スイツチA(クミ)	1
33	#02	SK-3514000-SC	WOOD SCREW D=5.1 L=40	マシメクシツ D=5.1 L=40	2
34	#02	MA0-11532000	CORD STAPLE	コト・ステツク	2
35		107-76953	RELAY CABLE ASM.	チユウイカク・メシ	1
36		107-41759	GROUND WIRE ASM.	グラント・センシツ	1

NOTE (注記)

#01... FOR LU-2266N-7  
 #02... FOR DL KNEE SWITCH TYPE  
 #03... EXCEPT JA  
 #04... OPTIONAL PARTS

LU-2266N-7用  
 DL膝スイッチ仕様用  
 JA向けは除く  
 オプション部品

## 22. MUTUAL RISING QUANTITY TRANSFER COMPONENTS

### 交互上昇量切替装置関係

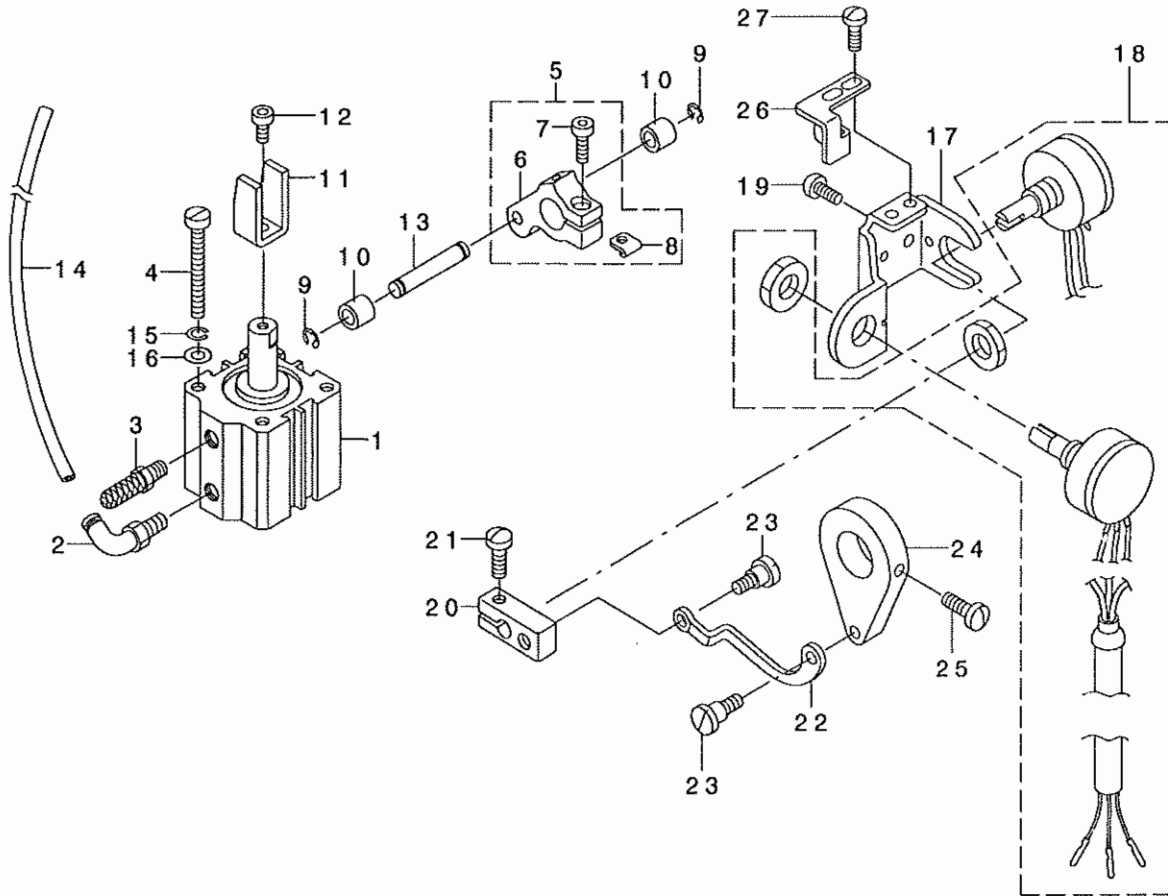

REF. NO	NOTE	PART NO.	DESCRIPTION	ヒヨク	Qty
1	#01	PA-2502006-00	JIG CYLINDER	ジグ シリンダ	1
2	#01	PJ-3040605-01	ELBOW	エルボ	1
3	#01	PX-0105020-00	MUFFLER	マフラ	1
4	#01	SM-6044500-SP	SCREW	ヒラネジ	2
5	#01	107-35959	VERTICAL CYLINDER ARM ASM.	コウゴ シ' ヨウケ' シリンダ' -ウデ' (クミ)	1
6		107-35900	VERTICAL CYLINDER ARM	コウゴ シ' ヨウケ' シリンダ' -ウデ'	(1)
7		SM-6051402-TP	SCREW M5X0.8 L=14	ロツカクアナホ' ルト	(1)
8		107-11406	SPACER B	スハ' -サB	(1)
9	#01	RE-0320000-KO	E-RING 3.2	Eカ' タトメワ 3.2	2
10	#01	B3031-141-H00	CONNECTING STUD	タ' キガ' イト' コロ	2
11	#01	107-36007	ROLLER HOLDER	ローラ-ウケ	1
12	#01	SM-6050802-TP	SCREW M5X0.8 L=8	ロツカクアナホ' ルト M5X0.7 L=8	1
13	#01	B1504-210-000	CONNECTING SHAFT	ソレノイト' レンクウツ' ク	1
14	#01	BT-0600401-EB	TUBE	チューブ	1.55
15	#01	WS-0410002-KN	SPRING WASHER	ハ' ネサ' カ' ネ M4	2
16	#01	WP-0450846-SP	WASHER	ヒラサ' カ' ネ	2
17		107-37500	SPEED VOLUME FITTING PLATE	ソクト' カハンホ' リユ-ムトリツケイタ	1
18		231-52051	CD POTENTIAL METER ASM.	CDホ' テンシヨメ-タクミ	1
19		SS-7110910-SP	SCREW 11/64-40 L=8.5	マルヒラネジ' 11/64-40 L=8.5	2
20		107-37609	VOLUME ARM	ホ' リユ-ムウデ'	1
21		SS-7110910-SP	SCREW 11/64-40 L=8.5	マルヒラネジ' 11/64-40 L=8.5	1
22		107-37708	SPEED VOLUME LINK	ソクト' カハンホ' リユ-ムリンク	1
23		SD-0550212-TP	HINGE SCREW D=5.5 H=2.1	タ' ソネジ' D=5.5 H=2.1	2
24		107-37807	VOLUME LINK ARM	ホ' リユ-ムリンクウデ'	1
25		SS-7110910-SP	SCREW 11/64-40 L=8.5	マルヒラネジ' 11/64-40 L=8.5	1
26		107-38755	PRESSER PLATE ASM.	ホ' リユ-ムオサエイタ(クミ)	1
27		SS-7110510-SP	SCREW 11/64-40 L=5	マルヒラネジ' 11/64-40 L= 5	2

NOTE (注記)

#01...OPTIONAL PARTS

オプ' シヨソ部品



## 23. BACK TUCK COMPONENTS

バックタック関係

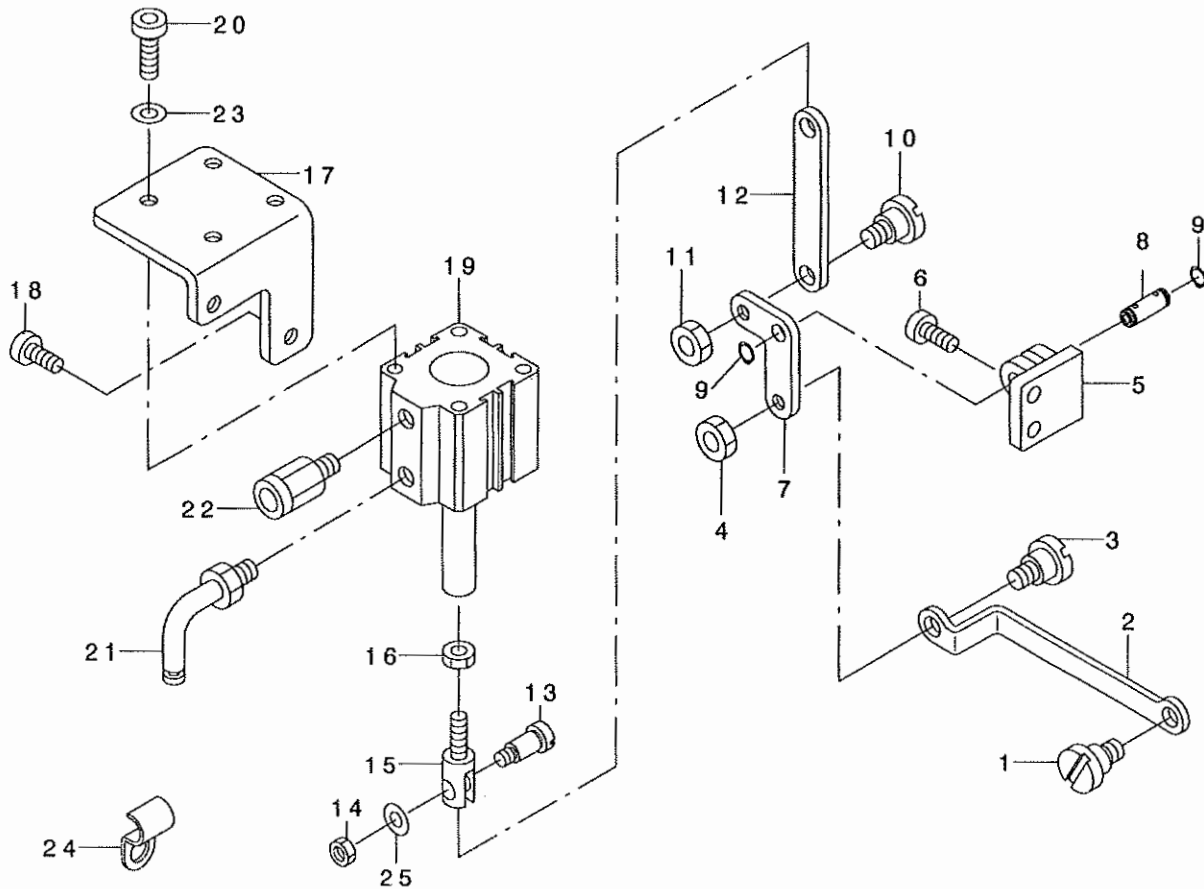

REF. NO	NOTE	PART NO.	DESCRIPTION	ヒョウメイ	Qty
1		SD-0800352-SP	HINGE SCREW D= 8 H= 3.5	タ'ンネシ' D=8 H=3.5	1
2		107-36403	BACKWARD FEED ROD	キ'ヤクオクリロッド'	1
3		SD-0800352-SP	HINGE SCREW D= 8 H= 3.5	タ'ンネシ' D=8 H=3.5	1
4		NS-6150540-SP	NUT 15/64-28	ロツカクナツト 15/64-28	1
5		107-75807	LINK FITTING BASE	キ'ヤクオクリリンクトリツケタ'イ	1
6		SS-6151440-SP	SCREW 15/64-28 L=14	ヒラネシ' 15/64-28 L=14	2
7		107-75906	BACKWARD FEED LINK	キ'ヤクオクリリンク	1
8		107-18906	VERTICAL FEED LINK SHAFT	シ'ヨウケ'オクリリンクシ'ク	1
9		RC-0650811-KP	RETAINING RING	Cカ'タメツ	2
10		SD-0800402-TP	HINGE SCREW D= 8 H= 4	タ'ンネシ' D=8 H=4	1
11		NS-6150430-SP	NUT 15/64-28	ロツカクナツト 15/64-28	1
12		107-37302	CYLINDER CONNECTION RING	キ'ヤクオクリリンク'レンケツカン	1
13		SD-0791271-SP	HINGE SCREW D= 7.94 H=12.7	タ'ンネシ' D=7.94 H=12.7	1
14		NS-6150430-SP	NUT 15/64-28	ロツカクナツト 15/64-28	2
15		107-36601	CYLINDER KNUCKLE JOINT	キ'ヤクオクリリンク'ナツクルシ'ヨイン	1
16		NM-6060001-SE	NUT M6	ロツカクナツト M6 1シユ	1
17		107-44506	CYLINDER INSTALLATION BASE	キ'ヤクオクリリンク'トリツケタ'イ	1
18		SS-6151440-SP	SCREW 15/64-28 L=14	ヒラネシ' 15/64-28 L=14	2
19		PA-3201502-00	JIG CYLINDER	シ'ク'シリンド'ア	1
20		SM-6061802-TP	SCREW M6 L=18	ロツカクアナホ'ルト	4
21		PJ-3040651-02	ELBOW	エルホ'	1
22		PX-0151010-00	MUFFLER	マフラ	1
23		WP-0641601-SD	WASHER M6	ヒラサ'カ'ネ ミカ'キマル M6	4
24		B3538-112-000	OIL RETURN TUBE HOLDER	カンリュウ ハ'イフ'オサエ	1
25		WP-0621016-SD	WASHER 6.2X13X1	ヒラサ'カ'ネ 6.2X13X1	1

24. TABLE OF EXCHANGING GAUGE PARTS(LU-2266N-7)

交換ゲージ部品一覧表 (LU-2266N-7)

mm Needle width 針 幅	Set number 代表品番	Needle clamp asm. 針止め組 SS-8080410-TP	Needle rod thread 針棒螺紋 SS-6060440-TP	Feed dog 送り歯	Pressor foot asm. 押え足組	Finger Guard 指ガード	Waking foot asm. 置き足組	Throat plate 針盤 Max. stitch length:6mm 最大送り:6mm	Sliding plate (left) 送り板(左)	Sliding plate (right) 送り板(右)										
											Ref.no	Parts no.	Ref.no	Parts no.	Ref.no	Parts no.	Ref.no	Parts no.		
(4)	1	107-84551	27	107-78007	43	107-81557	56	107-86903	62	107-83058	75	107-84502	88	107-86309	92	107-01803				
6	2	107-84650	15	107-77854	27	107-79007	31	107-80194	44	107-81656	56	107-86903	63	107-83157	76	107-84601	88	107-86309	92	107-01803
8	3	107-84759	16	107-77753	27	107-79007	32	107-80203	45	107-81755	56	107-86903	64	107-83256	77	107-84700	88	107-86309	92	107-01803
10	4	107-84858	17	107-77852	28	107-79106	33	107-80302	46	107-81854	57	107-87000	65	107-83355	78	107-84809	89	107-86408	93	107-86002
12	5	107-84957	18	107-77851	28	107-79106	34	107-80401	47	107-81953	57	107-87000	66	107-83454	79	107-84908	89	107-86408	93	107-86002
(14)	6	107-85053	19	107-78058	28	107-79106	35	107-80500	48	107-82050	58	107-87109	67	107-83552	80	107-85004	89	107-86408	93	107-86002
(16)	7	107-85152	20	107-78157	28	107-79106	36	107-80609	49	107-82159	58	107-87109	68	107-83552	81	107-85103	89	107-86408	93	107-86002
(18)	8	107-85251	21	107-78256	28	107-79106	37	107-80708	50	107-82258	58	107-87109	69	107-83751	82	107-85202	89	107-86408	93	107-86002
20	9	107-85350	22	107-78355	29	B1403-526-000	38	107-80807	51	107-82357	59	107-87208	70	107-83850	83	107-85301	90	107-86507	94	107-86101
(22)	10	107-85459	23	107-78454	29	B1403-526-000	39	107-80906	52	107-82456	59	107-87208	71	107-83959	84	107-85400	90	107-86507	94	107-86101
(24)	11	107-85558	24	107-78553	29	B1403-526-000	40	107-81003	53	107-82555	59	107-87208	72	107-84056	85	107-85509	90	107-86507	94	107-86101
(30)	12	107-85657	25	107-78652	29	B1403-526-000	41	107-81102	54	107-82654	60	107-87307	73	107-84155	86	107-85608	90	107-86507	94	107-86101
(36)	13	107-85756	26	107-78751	29	B1403-526-000	42	107-81201	55	107-82753	61	107-87406	74	107-84254	87	107-85707	91	107-86606	95	107-86200

Note... Sets having ( ) with needle width are specially made to order.  
 Sliding plate(right) and sliding plate(left) are not included in the set nos.

注記... 針幅に( )のついているセットは、特別注文部品です。  
 代表品番の構成内容に送り板(右)、送り板(左)は含まれません。

REF. NO	NOTE	PART NO.	DESCRIPTION	ヒヨメイ	Qty
1		107-84551	GAUGE SET 4MM	4MMカ-シ'セツト	1
2		107-84650	GAUGE SET 6MM	6MMカ-シ'セツト	1
3		107-84759	GAUGE SET 8MM	8MMカ-シ'セツト	1
4		107-84858	GAUGE SET 10MM	10MMカ-シ'セツト	1
5		107-84957	GAUGE SET 12MM	12MMカ-シ'セツト	1
6		107-85053	GAUGE SET 14MM	14MMカ-シ'セツト	1
7		107-85152	GAUGE SET 16MM	16MMカ-シ'セツト	1
8		107-85251	GAUGE SET 18MM	18MMカ-シ'セツト	1
9		107-85350	GAUGE SET 20MM	20MMカ-シ'セツト	1
10		107-85459	GAUGE SET 22MM	22MMカ-シ'セツト	1
11		107-85558	GAUGE SET, 24MM	24MMカ-シ'セツト	1
12		107-85657	GAUGE SET, 30MM	30MMカ-シ'セツト	1
13		107-85756	GAUGE SET 36MM	36MMカ-シ'セツト	1
14		107-77555	NEEDLE CLAMP ASM. 4MM	ハサ'メ(クミ)4MM	1
15		107-77654	NEEDLE CLAMP ASM. 6MM	ハサ'メ(クミ)6MM	1
16		107-77753	NEEDLE CLAMP ASM. 8MM	ハサ'メ(クミ)8MM	1
17		107-77852	NEEDLE CLAMP ASM. 10MM	ハサ'メ(クミ)10MM	1
18		107-77951	NEEDLE CLAMP ASM. 12MM	ハサ'メ(クミ)12MM	1
19		107-78058	NEEDLE CLAMP ASM. 14MM	ハサ'メ(クミ)14MM	1
20		107-78157	NEEDLE CLAMP ASM. 16MM	ハサ'メ(クミ)16MM	1
21		107-78256	NEEDLE CLAMP ASM. 18MM	ハサ'メ(クミ)18MM	1
22		107-78355	NEEDLE CLAMP ASM. 20MM	ハサ'メ(クミ)20MM	1
23		107-78454	NEEDLE CLAMP ASM. 22MM	ハサ'メ(クミ)22MM	1
24		107-78553	NEEDLE CLAMP ASM. 24MM	ハサ'メ(クミ)24MM	1
25		107-78652	NEEDLE CLAMP ASM. 30MM(SP)	ハサ'メ(クミ)30MM	1
26		107-78751	NEEDLE CLAMP ASM., 36MM	ハサ'メ(クミ)36MM	1
27		107-79007	NEEDLE BAR THREAD GUIDE 4-8MM	ハサ'メウイカ(4-8MM)	1
28		107-79106	NEEDLE BAR THREAD GUIDE PLATE	ハサ'メウイカ(10-18MM)	1
29		B1403-526-000	THREAD GUIDE	ハサ'メイブツ	1
30		107-80005	FEED DOG (4MM)	オツリ(4MM)	1
31		107-80104	FEED DOG (6MM)	オツリ(6MM)	1
32		107-80203	FEED DOG (8MM)	オツリ(8MM)	1
33		107-80302	FEED DOG (10MM)	オツリ(10MM)	1
34		107-80401	FEED DOG (12MM)	オツリ(12MM)	1
35		107-80500	FEED DOG (14MM)	オツリ(14MM)	1
36		107-80609	FEED DOG (16MM)	オツリ(16MM)	1
37		107-80708	FEED DOG (18MM)	オツリ(18MM)	1
38		107-80807	FEED DOG (20MM)	オツリ(20MM)	1
39		107-80906	FEED DOG (22MM)	オツリ(22MM)	1
40		107-81003	FEED DOG (24MM)	オツリ(24MM)	1
41		107-81102	FEED DOG 30MM(SP)	オツリ(30MM)	1
42		107-81201	FEED DOG 36MM	オツリ(36MM)	1
43		107-81557	PRESSER FOOT ASM. 4MM	オツリ(クミ)4MM	1
44		107-81656	PRESSER FOOT ASM. 6MM	オツリ(クミ)6MM	1
45		107-81755	PRESSER FOOT ASM. 8MM	オツリ(クミ)8MM	1
46		107-81854	PRESSER FOOT ASM.	オツリ(クミ)10MM	1
47		107-81953	PRESSER FOOT ASM. 12MM	オツリ(クミ)12MM	1
48		107-82050	PRESSER FOOT ASM. 14MM	オツリ(クミ)14MM	1
49		107-82159	PRESSER FOOT ASM. 16MM	オツリ(クミ)16MM	1
50		107-82258	PRESSER FOOT ASM. 18MM	オツリ(クミ)18MM	1
51		107-82357	PRESSER FOOT ASM. 20MM	オツリ(クミ)20MM	1
52		107-82456	PRESSER FOOT ASM. 22MM	オツリ(クミ)22MM	1
53		107-82555	PRESSER FOOT ASM. 24MM	オツリ(クミ)24MM	1
54		107-82654	PRESSER FOOT ASM. 30MM(SP)	オツリ(クミ)30MM	1
55		107-82753	PRESSER FOOT ASM., 36MM	オツリ(クミ)36MM	1
56		107-86903	FINGER GUARD COVER (4-8MM)	エ'キ'カ'カ'-(4-8MM)	1
57		107-87000	FINGER GUARD COVER (10-12MM)	エ'キ'カ'カ'-(10-12MM)	1
58		107-87109	FINGER GUARD COVER (14-18MM)	エ'キ'カ'カ'-(14-18MM)	1
59		107-87208	FINGER GUARD COVER (20-24MM)	エ'キ'カ'カ'-(20-24MM)	1
60		107-87307	FINGER GUARD COVER (30MM)	エ'キ'カ'カ'-(30MM)	1
61		107-87406	FINGER GUARD COVER (36MM)	エ'キ'カ'カ'-(36MM)	1
62		107-83058	FEED FOOT ASM. 4MM	オツリ(クミ)4MM	1
63		107-83157	FEED FOOT ASM. 6MM	オツリ(クミ)6MM	1
64		107-83256	FEED FOOT ASM. 8MM	オツリ(クミ)8MM	1
65		107-83355	FEED FOOT ASM. 10MM	オツリ(クミ)10MM	1
66		107-83454	FEED FOOT ASM. 12MM	オツリ(クミ)12MM	1
67		107-83553	FEED FOOT ASM. 14MM	オツリ(クミ)14MM	1
68		107-83652	FEED FOOT ASM. 16MM	オツリ(クミ)16MM	1
69		107-83751	FEED FOOT ASM. 18MM	オツリ(クミ)18MM	1
70		107-83850	FEED FOOT ASM. 20MM	オツリ(クミ)20MM	1
71		107-83959	FEED FOOT ASM. 22MM	オツリ(クミ)22MM	1
72		107-84056	FEED FOOT ASM. 24MM	オツリ(クミ)24MM	1
73		107-84155	FEED FOOT ASM. 30MM(SP)	オツリ(クミ)30MM	1
74		107-84254	FEED FOOT ASM., 36MM	オツリ(クミ)36MM	1
75		107-84502	THROAT PLATE (4MM)	ハサ'メ(4MM)	1
76		107-84601	THROAT PLATE (6MM)	ハサ'メ(6MM)	1
77		107-84700	THROAT PLATE (8MM)	ハサ'メ(8MM)	1
78		107-84809	THROAT PLATE (10MM)	ハサ'メ(10MM)	1
79		107-84908	THROAT PLATE (12MM)	ハサ'メ(12MM)	1
80		107-85004	THROAT PLATE (14MM)	ハサ'メ(14MM)	1
81		107-85103	THROAT PLATE (16MM)	ハサ'メ(16MM)	1
82		107-85202	THROAT PLATE (18MM)	ハサ'メ(18MM)	1
83		107-85301	THROAT PLATE (20MM)	ハサ'メ(20MM)	1
84		107-85400	THROAT PLATE (22MM)	ハサ'メ(22MM)	1
85		107-85509	THROAT PLATE (24MM)	ハサ'メ(24MM)	1
86		107-85608	THROAT PLATE 30MM(SP)	ハサ'メ(30MM)	1
87		107-85707	THROAT PLATE 36MM	ハサ'メ(36MM)	1
88		107-86309	SLIDE PLATE, LEFT 4-8MM	ス'リ'タ(ヒ'タ'リ)4-8MM	1
89		107-86408	SLIDE PLATE, LEFT 10-18MM	ス'リ'タ(ヒ'タ'リ)10-18MM	1
90		107-86507	SLIDE PLATE, LEFT 20-30MM	ス'リ'タ(ヒ'タ'リ)20-30MM	1
91		107-86606	SLIDING PLATE, LEFT 36MM	ス'リ'タ(ヒ'タ'リ)36MM	1
92		107-01803	SLIDE PLATE, RIGHT	ス'リ'タ(ヒ'タ'リ)36MM	1
93		107-86002	SLIDE PLATE, RIGHT 10-18MM	ス'リ'タ(ヒ'タ'リ)10-18MM	1
94		107-86101	SLIDE PLATE, RIGHT 20-30MM	ス'リ'タ(ヒ'タ'リ)20-30MM	1
95		107-86200	SLIDING PLATE, RIGHT 36MM	ス'リ'タ(ヒ'タ'リ)36MM	1

25. TABLE OF EXCHANGING GAUGE PARTS(LU-2216N-7)(1)

交換ゲージ部品一覧表 (LU-2216N-7) (1)

Walking foot 送り足												
			Ref. no.	Part no.	Ref. no.	Part no.	Ref. no.	Part no.	Ref. no.	Part no.	Ref. no.	Part no.
Presser foot 押え足			1	107-11653	2	107-11752	3	107-11851	4	107-11950	5	107-45354
			6	107-45453	7	107-45552	8	107-45651	9	107-46352	10	107-46451
			11	107-46550	12	107-46659	13	107-12354	14	107-12057		
	15	107-12552	Standard 	—	—	—	—	—	—	—	○	—
	16	107-58456	*02	—	—	—	—	—	—	—	○	—
	17	107-12651	 *03	—	—	—	—	—	—	—	○	—
	18	107-12750	 *04	 *05	—	—	—	—	—	—	—	—

\*01. Without groove.

溝無しタイプ\*

To be used when the thread cannot be grasped at the sewing start.

縫い始めに糸が掴みにくい時に使用

\*02. For overlapped sections of material.

段部用

Common type for overlapped sections and flat sections, intermediate type between 10712552 and 10712651.

段部用・平部でも使用できる両用タイプ, 10712552と10712651の中間タイプ

\*03. For overlapped sections of material.

段部用

To be used when overlapped sections cannot be smoothly fed.

段部での乗り越えが悪い時に使用

\*04. For light-weight sponge.

薄いスポンジ用

To be used for resilient materials such as sponge.

スポンジ等の弾力性の有る素材に使用

\*05. For heavy-weight sponge.

厚いスポンジ用















To be used for further resilient materials.



より弾力性の有る素材に使用

REF. NO	NOTE	PART NO.	DESCRIPTION	ヒ ヲ メ イ	Qty
1		107-11653	FEED FOOT ASM.	オクリアツ(クミ)	1
2		107-11752	FEEDING FOOT (URETHANE)	オクリアツウレタンヨウ(クミ)	1
3		107-11851	FEEDING FOOT ASM. RIGHT	オクリアツミキ'カタオサエヨウ(クミ)	1
4		107-11950	FEEDING FOOT ASM. ,LEFT	オクリアツヒタ'リカタオサエヨウ(クミ)	1
5		107-45354	FEEDING FOOT (PIPING) 3MM	オクリアツハ'イビ'ソク'ヨウ 3ミリ(クミ)	1
6		107-45453	FEEDING FOOT (PIPING) 4MM	オクリアツハ'イビ'ソク'ヨウ 4ミリ(クミ)	1
7		107-45552	FEEDING FOOT (PIPING) 5MM	オクリアツハ'イビ'ソク'ヨウ 5ミリ(クミ)	1
8		107-45651	FEEDING FOOT (PIPING) 6MM	オクリアツハ'イビ'ソク'ヨウ 6ミリ(クミ)	1
9		107-46352	FEEDING FOOT (PIPING) 3MM ADJU	オクリアツカハソハ'イビ'ソク'ヨウ 3ミリ(	1
10		107-46451	FEEDING FOOT (PIPING) 4MM ADJU	オクリアツカハソハ'イビ'ソク'ヨウ 4ミリ(	1
11		107-46550	FEEDING FOOT (PIPING) 5MM ADJU	オクリアツカハソハ'イビ'ソク'ヨウ 5ミリ(	1
12		107-46659	FEEDING FOOT (PIPING) 6MM ADJU	オクリアツカハソハ'イビ'ソク'ヨウ 6ミリ(	1
13		107-12354	FEED FOOT ASM.	オクリアツ(ミツ'ナツ)クミ	1
14		107-12057	FEED FOOT ASM.	オクリアツ(ハハ'ヒロ'クミ)	1
15		107-12552	PRESSER FOOT ASM.	オサエアツ'クミ	1
16		107-58456	PRESSER FOOT ASM.	オサエアツ(オサエメソセキヨウ)クミ	1
17		107-12651	PRESSER FOOT ASM	オサエアツ'ソフ'ヨウ(クミ)	1
18		107-12750	PRESSER FOOT, URETHANE	オサエアツウレタンヨウ(クミ)	1

26. TABLE OF EXCHANGING GAUGE PARTS(LU-2216N-7)(2)

交換ゲージ部品一覧表 (LU-2216N-7) (2)

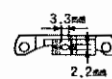
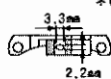
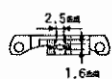
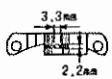
Walking foot 送り足																		
	Ref.no	Part no.	Ref.no	Part no.	Ref.no	Part no.	Ref.no	Part no.	Ref.no	Part no.	Ref.no	Part no.	Ref.no	Part no.	Ref.no	Part no.		
Presser foot 押え足	1	107-11653	2	107-11752	3	107-11851	4	107-11850	5	107-45354	9	107-46352	13	107-12354	14	107-12057		
	6	107-45453	10	107-46451	7	107-45552	11	107-46550	8	107-45651	12	107-46659						
	15	107-12859	—	—			—	—	—	—	—	—	—	—	—	—		
	16	107-12958	—	—	—	—			—	—	—	—	—	—	—	—		
	17	107-47350	—	—	—	—	—		Adjustable 調節式 	*05	—	—	—	—	—	—		
	18	107-47459	—	—	—	—	—				—	—	—	—	—	—	—	—
	19	107-47558	—	—	—	—	—				—	—	—	—	—	—	—	—
	20	107-47657	—	—	—	—	—				—	—	—	—	—	—	—	—
	21	107-13055	—	—	—	—	—	—	—	—	—	—	—	—	—	*06		

Feed dog 送り足				
				
Standard 標準	*01	For fine thread 細糸用		Wide type 幅広タイプ
Ref.no	22	23	24	25
Part no.	107-17106	107-17205	107-17304	107-39001

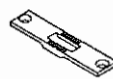
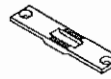
Throat plate 針板		
		
Standard 標準	Wide type 幅広タイプ	
Ref.no	26	27
Part no.	107-01704	107-02009

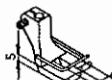
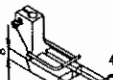
For machining 加工用			
			
To be machined to a walking foot. 送り足加工用	Type B to be machined to a walking foot. 送り足加工用B	Type A to be machined to a walking foot. 送り足加工用A	
Ref.no	28	29	30
Part no.	107-12255	107-48358	107-13253

Swing edge guide 角り定規

31
WAH-152010A0

\*01. Without groove.

溝無しタイプ

To be used when the thread cannot be grasped at the sewing start.

縫い始めに糸が絡みにくい時に使用

\*02. Right-edge presser.

右片押え

To be used to sew edges of material.

エッジを縫製する場合に使用

\*03. Left-edge presser.

左片押え

To be used to sew edges of material.

エッジを縫製する場合に使用

\*04. For piping.

パイピング用

To be used for general piping processes.

一般のパイピング工程に使用

\*05. For piping.

パイピング用

Permits adjustment of the needle position with respect to the pipe.

パイピングに対する針の位置が調整出来ます。

\*06. Wide type.

幅広タイプ

To be used when a sewing product cannot be smoothly fed.

縫製物の送りが悪い場合に使用

REF. NO	NOTE	PART NO.	DESCRIPTION	キ ヲ メ イ	Qty
1		107-11653	FEED FOOT ASM.	オクリアツ(クミ)	1
2		107-11752	FEEDING FOOT (URETHANE)	オクリアツウレタンヨウ(クミ)	1
3		107-11851	FEEDING FOOT ASM. RIGHT	オクリアツミキ' カタオサエヨウ(クミ)	1
4		107-11950	FEEDING FOOT ASM., LEFT	オクリアツヒタ' リカタオサエヨウ(クミ)	1
5		107-45354	FEEDING FOOT (PIPING) 3MM	オクリアツハ' イビ' ソク' ヨウ 3ミリ(クミ)	1
6		107-45453	FEEDING FOOT (PIPING) 4MM	オクリアツハ' イビ' ソク' ヨウ 4ミリ(クミ)	1
7		107-45552	FEEDING FOOT (PIPING) 5MM	オクリアツハ' イビ' ソク' ヨウ 5ミリ(クミ)	1
8		107-45651	FEEDING FOOT (PIPING) 6MM	オクリアツハ' イビ' ソク' ヨウ 6ミリ(クミ)	1
9		107-46352	FEEDING FOOT (PIPING) 3MM ADJU	オクリアツカハソハ' イビ' ソク' ヨウ 3ミリ(	1
10		107-46451	FEEDING FOOT (PIPING) 4MM ADJU	オクリアツカハソハ' イビ' ソク' ヨウ 4ミリ(	1
11		107-46550	FEEDING FOOT (PIPING) 5MM ADJU	オクリアツカハソハ' イビ' ソク' ヨウ 5ミリ(	1
12		107-46659	FEEDING FOOT (PIPING) 6MM ADJU	オクリアツカハソハ' イビ' ソク' ヨウ 6ミリ(	1
13		107-12354	FEED FOOT ASM.	オクリアツ(ミツ' ナツ)クミ	1
14		107-12057	FEED FOOT ASM.	オクリアツ(ハハ' ヒロ クミ)	1
15		107-12859	FEEDING FOOT, RIGHT	オサエアツミキ' カタオサエヨウ(クミ)	1
16		107-12958	PRESSER FOOT, LEFT	オサエアツヒタ' リカタオサエヨウ(クミ)	1
17		107-47350	PRESSER FOOT (PIPING) 3MM	オサエアツ 3ミリハ' イビ' ソク' ヨウ	1
18		107-47459	PRESSER FOOT (PIPING) 4MM	オサエアツ 4ミリハ' イビ' ソク' ヨウ	1
19		107-47558	PRESSER FOOT (PIPING) 5MM	オサエアツ 5ミリハ' イビ' ソク' ヨウ	1
20		107-47657	PIPING FOOT 6MM	オサエアツ 6ミリハ' イビ' ソク' ヨウ	1
21		107-13055	FEED FOOT ASM.	オサエアツ(ハハ' ヒロ クミ)	1
22		107-17106	FEED DOG	オクリハ'	1
23		107-17205	FEED DOG, W/O GROOVE	オクリハ' (ミツ' ナツ)	1
24		107-17304	FEED DOG (THIN THREAD)	オクリハ' (ホソイトヨウ)	1
25		107-39001	FEED DOG	オクリハ' (ハハ' ヒロ)	1
26		107-01704	THROAT PLATE	ハリイタ	1
27		107-02009	THROAT PLATE	ハリイタ(ハハ' ヒロ)	1
28		107-12255	FEED FOOT ASM.	オクリアツ(カコウヨウA)クミ	1
29		107-48358	PRESSER FOOT ASM.	オサエアツ(カコウヨウB)クミ	1
30		107-13253	PRESSER FOOT ASM.	オサエアツ(カコウヨウA)クミ	1
31		MAH-152010A0	RULER	ツリツ' ヨウキ' (クミ)	1

NUMERICAL INDEX OF PARTS

索引

PART NO 品番	PAGE 頁	REF NO	PART NO 品番	PAGE 頁	REF NO	PART NO 品番	PAGE 頁	REF NO	PART NO 品番	PAGE 頁	REF NO
BP-600000-00	24	11	B3521-245-000	28	14	HK-0045900-0A	30	42	RE-0400000-KO	4	73
BT-0400251-EA	28	55	B3525-357-000	28	42	HK-0174200-60	30	33	RE-0400000-KO	8	13
BT-0500300-E0	28	5	B3534-012-000	28	43	HR-0291015-20	30	37	RE-0400000-KO	10	15
BT-0500300-E0	28	13	B3538-112-000	38	24	HW-0008400-80	30	34	RE-0400000-KO	18	14
BT-0500300-E0	28	15	B8111-220-000	32	12	HW-2002500-00	30	29	RE-0400000-KO	20	14
BT-0500300-E0	28	29	B8112-220-000	32	13	HW-5001400-00	14	37	RE-0500000-KO	8	64
BT-0500300-E0	28	40	B8202-205-000	32	11	HW-5001800-00	30	45	RE-0500000-KO	12	6
BT-0500300-E0	28	46	B8213-012-000	32	7	HX-0029500-0A	26	39	RE-0500000-KO	12	44
BT-0500300-E0	28	69	B8228-125-000	28	9	HX-0029500-0A	30	22	RE-0500000-KO	12	45
BT-0500300-E0	28	70	B8228-125-000	28	33	HX-0029500-0B	26	38	RE-0500000-KO	24	8
BT-0500300-E0	28	76	B9101-552-000	36	1	HX-0029500-0B	30	2	RE-0600000-KO	6	12
BT-0600401-EB	30	11	B9109-555-000	36	2	HX-0029500-0C	30	15	RO-0681901-00	28	73
BT-0600401-EB	30	12	B9111-012-000	36	4	HX-0029500-00	30	21	RO-0982401-00	18	32
BT-0600401-EB	30	13	B9121-012-0A0	36	7				RO-0982401-00	20	32
BT-0600401-EB	37	14	B9121-012-000	32	14	MAH-152010A0	44	31	RO-1182401-00	10	20
BT-0600402-EA	10	21				MAO-11532000	33	40	RO-2943101-00	4	34
BT-0600402-EA	28	3	CM-3002001-A1	2	48	MAO-11532000	36	34	RO-3122401-00	4	50
BT-0600402-EA	28	24	CM-3002001-01	2	47	MC-3210014-00	6	8	RO-3573501-00	18	17
BT-0600402-EA	28	28	CQ-2000000-00	26	12	MC-3210014-00	6	18	RO-3573501-00	20	17
BT-0600402-EA	28	47	CQ-2020000-00	6	23	MC-3210014-02	36	14			
BT-0600402-EA	28	53	CQ-2020000-00	6	24	MC-3210014-02	36	15	SB-1100009-00	18	9
BT-0630520-Z0	36	20	CQ-2020000-00	8	61	MDF-RX1600C0	36	6	SB-1100009-00	20	10
BT-0800501-EB	30	8	CQ-2020000-00	8	72	M9637-110-000	30	32	SB-1100010-00	18	10
BT-0800602-E0	28	17	CQ-2020000-00	12	40	M9638-110-000	14	50	SB-1100010-00	20	11
BT-0800602-E0	28	22	CQ-2020000-00	12	41	M9640-110-000	30	46	SB-1150004-00	18	11
BT-0800602-E0	28	72	CQ-2020000-00	12	42				SB-1150004-00	20	12
B1111-563-000	2	30	CQ-2020000-00	28	56	NM-6030001-SC	32	16	SB-1150009-00	18	12
B1114-280-000	10	39	CQ-2020000-00	28	67	NM-6040001-SC	14	43	SD-0470281-SP	22	19
B1114-517-000	36	9	CQ-2520000-00	8	71	NM-6040001-SN	4	43	SD-0470281-SP	22	50
B1131-057-000	2	20	CQ-2520000-00	8	73	NM-6040003-SC	22	23	SD-0500301-SP	16	25
B1148-141-H00	10	32	CQ-2520000-00	8	74	NM-6040003-SC	22	54	SD-0500301-SP	16	30
B1150-490-000	2	32	CQ-2520000-00	8	75	NM-6050001-SE	33	13	SD-0500481-TP	14	20
B1215-804-000	18	8	CQ-2520000-00	8	76	NM-6050001-SE	33	17	SD-0500721-SP	14	29
B1215-804-000	20	9	CQ-2520000-00	8	77	NM-6050001-SE	33	29	SD-0500721-SP	16	23
B1308-055-000	4	58	CQ-2520000-00	28	48	NM-6050001-SE	33	42	SD-0550212-TP	37	23
B1309-055-000	4	60	CS-0790731-SH	14	47	NM-6060001-SE	33	21	SD-0640322-TP	4	62
B1310-055-000	4	59	CS-0790731-SH	16	13	NM-6060001-SE	38	16	SD-0700332-SP	24	14
B1314-055-000	4	61	CS-1201011-SH	10	22	NM-6080001-SE	26	37	SD-0720331-SP	26	36
B1403-526-000	40	29	CS-1201011-SH	26	25	NM-6160511-SE	33	18	SD-0790203-SP	26	2
B1504-210-000	37	13	CS-1501011-TH	8	2	NM-6860003-SC	30	39	SD-0791271-SP	38	13
B1526-527-00G	8	58	CS-1501011-TH	8	46	NS-6110310-SP	22	18	SD-0800352-SP	38	1
B1636-158-000	4	71	CS-1501011-TH	12	37	NS-6110310-SP	22	49	SD-0800352-SP	38	3
B1639-158-000	4	72				NS-6110310-SP	23	31	SD-0800402-TP	38	10
B1648-122-000	28	57	D2430-555-B00	23	15	NS-6110360-SP	23	12	SD-0901201-TP	26	8
B2311-019-000	16	28	D2515-232-D00	10	37	NS-6150430-SP	24	16	SK-3241601-SC	32	10
B3031-141-H00	14	30	D2611-555-B00-A	28	52	NS-6150430-SP	36	17	SK-3382001-SE	33	22
B3031-141-H00	16	22	D2611-555-B00-A	30	19	NS-6150430-SP	38	11	SK-3482500-SC	30	48
B3031-141-H00	37	10	D2611-555-B00-A	30	53	NS-6150430-SP	38	14	SK-3482500-SC	32	22
B3112-704-000	22	37	D3168-555-H0B	22	15	NS-6150540-SP	38	4	SK-3514000-SC	36	33
B3126-012-000	22	40	D3168-555-H0B	23	33	NS-6620310-SP	36	10	SK-3514001-SE	36	23
B3126-352-000	22	12	D3301-772-TAB	33	20				SM-0050801-SC	30	6
B3128-526-000	22	35	D6028-555-BOA	14	45	PA-2502006-00	37	1	SM-1040801-SC	6	21
B3129-012-A00	22	10	D6029-555-BOA	30	16	PA-3201502-00	38	19	SM-1082501-SE	26	34
B3129-053-000	22	38	D6042-555-B00	30	43	PA-4002002-00	26	32	SM-3030650-SC	4	21
B3132-552-000	22	39	D6043-555-B00	14	44	PF-0551030-A0	30	5	SM-3031401-SE	32	15
B3138-512-000	2	24	D6043-555-B00	26	6	PJ-0325160-01	30	4	SM-4020801-SD	28	37
B3205-210-000	23	7	D6043-555-B00	30	17	PJ-3010651-04	26	33	SM-4030601-SC	18	31
B3207-210-000	23	16	D6043-555-B00	30	44	PJ-3010851-02	30	7	SM-4030601-SC	20	31
B3208-210-000	23	18	D7101-245-E00	36	18	PJ-3040605-01	37	2	SM-4040601-SB	14	49
B3211-210-000	23	10	D7102-245-E00	36	19	PJ-3040651-02	38	21	SM-4040601-SC	28	63
B3212-210-000	23	11				PS-0150065-KP	35	17	SM-4040601-SN	30	20
B3214-047-000	23	34	EA-9500B00-00	28	21	PS-0200102-KH	23	17	SM-4051001-SC	30	54
B3216-047-000	22	14	EA-9500B00-00	28	80	PS-0300082-KH	24	7	SM-4051405-SE	33	12
B3216-047-000	23	32	EA-9500B01-00	28	54	PS-0400322-KP	10	11	SM-4051405-SE	33	30
B3305-704-000-A	33	28	EA-9500B01-00	28	82	PS-0500452-KP	26	28	SM-4052501-SC	30	10
B3309-704-0A0	33	43	EA-9500B01-00	30	28	PV-0399010-A0	30	9	SM-4061201-SE	33	41
B3311-012-000	33	33	EA-9500B02-00	14	42	PX-0105020-00	37	3	SM-4861201-SC	30	38
B3311-704-000	33	26	EA-9500B02-00	28	81	PX-0151010-00	38	22	SM-6030602-TP	6	26
B3317-704-000	33	37	E8760-452-D00	30	30				SM-6030802-TP	14	9
B3318-704-L00-A	33	25				RC-0560711-KP	8	22	SM-6030802-TP	16	11
B3319-704-L00	33	23	GAK-A14040C0	36	32	RC-0650811-KP	12	13	SM-6031202-TP	14	36
B3320-704-L00-A	33	32	GAK-A1503000	30	14	RC-0650811-KP	38	9	SM-6040552-TP	34	8
B3321-704-L00	33	39	GAK-79001AA0	30	1	RC-0740811-KP	8	67	SM-6040552-TP	35	7
B3416-552-000	8	63				RC-1200001-KP	24	3	SM-6040602-TP	14	13
B3510-019-000	2	45	HK-0039300-00	30	31	RC-1200001-KP	26	9	SM-6040602-TP	14	31
B3520-245-000	28	16	HK-0045900-0A	30	18	RE-0320000-KO	37	9	SM-6040602-TP	16	34



NUMERICAL INDEX OF PARTS

索引

PART NO 品番	PAGE 頁	REF NO	PART NO 品番	PAGE 頁	REF NO	PART NO 品番	PAGE 頁	REF NO	PART NO 品番	PAGE 頁	REF NO
SM-6040602-TP	16	36	SQ-1150451-MZ	4	26	SS-7121610-SP	2	11	101-09809	8	62
SM-6040802-TP	18	37	SQ-1150451-MZ	18	33	SS-7121610-SP	2	13	101-09809	18	20
SM-6040802-TP	20	37	SQ-1150451-MZ	18	38	SS-7121610-SP	10	6	101-09809	20	20
SM-6040802-TP	34	10	SQ-1150451-MZ	20	33	SS-7121610-SP	10	30	101-11201	18	13
SM-6040802-TP	35	9	SQ-1150451-MZ	20	38	SS-7620750-SP	10	4	101-11201	20	13
SM-6041012-TP	6	17	SQ-1680701-MZ	28	83	SS-7621040-SP	23	36	101-12506	18	21
SM-6041202-TP	14	17	SS-1110840-SP	18	35	SS-8080410-TP	6	3	101-12506	20	21
SM-6041202-TP	14	23	SS-1110840-SP	20	35	SS-8080410-TP	35	14	101-12605	18	18
SM-6041202-TP	16	16	SS-2090710-SP	2	23	SS-8080610-SP	18	15	101-12605	20	18
SM-6041202-TP	16	27	SS-2090710-SP	2	46	SS-8080610-SP	20	15	101-12704	18	19
SM-6044500-SP	37	4	SS-2110915-SP	34	4	SS-8110422-TP	12	7	101-12704	20	19
SM-6050802-TP	8	43	SS-2110915-SP	35	3	SS-8110422-TP	14	33	101-19907	10	38
SM-6050802-TP	28	51	SS-3061310-SP	22	51	SS-8110422-TP	16	14	101-20004	10	36
SM-6050802-TP	37	12	SS-5090420-SP	22	27	SS-8111610-SP	23	26	101-23701	28	79
SM-6051202-TP	26	4	SS-5090420-SP	22	57	SS-8120740-SP	4	47	101-24204	23	35
SM-6051402-TP	8	55	SS-5150510-SP	32	21	SS-8120740-SP	6	19	101-26803	28	12
SM-6051402-TP	14	27	SS-6060440-TP	35	16	SS-8120740-SP	8	24	103-20109	22	3
SM-6051402-TP	16	21	SS-6080610-TP	18	41	SS-8120740-SP	8	66	103-20208	22	5
SM-6051402-TP	18	3	SS-6080610-TP	20	41	SS-8120740-SP	24	19	103-20208	22	33
SM-6051402-TP	20	3	SS-6081210-SP	28	59	SS-8150510-TP	4	44	105-02300	23	22
SM-6051402-TP	26	15	SS-6090510-SP	2	21	SS-8150510-TP	12	48	105-23702	4	39
SM-6051402-TP	37	7	SS-6090620-SP	23	23	SS-8150750-SP	28	19	105-27901	28	66
SM-6051602-TP	4	66	SS-6110610-TP	30	52	SS-8150822-TP	4	15	105-39906	32	3
SM-6051602-TP	36	30	SS-6110630-TP	8	53	SS-8151150-TP	4	70	105-39906	32	6
SM-6052502-TP	14	32	SS-6111010-SP	34	12	SS-8660410-SP	8	3	105-91709	4	56
SM-6052502-TP	16	7	SS-6111010-SP	35	11	SS-8660410-SP	8	47	107-00508	2	37
SM-6061202-TP	26	24	SS-6111140-SP	14	41	SS-8660410-SP	12	38	107-00706	2	9
SM-6061210-SC	26	22	SS-6111140-SP	18	16	SS-8660512-TP	4	5	107-01308	2	17
SM-6061210-SC	28	39	SS-6111140-SP	20	16	SS-8660610-TP	10	29	107-01654	34	1
SM-6061552-TP	12	26	SS-6121010-SP	2	5	SS-8660610-TP	26	26	107-01654	35	1
SM-6061552-TP	12	34	SS-6121010-SP	2	8	SS-8660810-TP	8	27	107-01704	34	2
SM-6061602-TP	8	34	SS-6121010-SP	2	14	SS-8661012-TP	12	22	107-01704	44	26
SM-6061610-SC	33	6	SS-6121010-SP	2	27				107-01803	34	5
SM-6061610-SC	33	24	SS-6121010-SP	8	49	TA-1050504-RO	2	19	107-01803	40	92
SM-6061650-TP	12	3	SS-6121010-SP	22	28	TA-1050504-RO	12	49	107-01902	34	6
SM-6061802-TP	38	20	SS-6121010-SP	28	26	TA-1250406-RO	2	3	107-02009	34	3
SM-6062002-TP	18	51	SS-6121010-SP	30	55	TA-1250504-RO	2	36	107-02009	44	27
SM-6062002-TP	20	48	SS-6121050-SP	8	16	TA-1450404-RO	28	1	107-02108	28	45
SM-6062502-TP	10	3	SS-6121210-SP	2	38	TA-2050406-RO	2	6	107-02207	28	65
SM-6063502-TP	36	28	SS-6121860-SP	4	68	TA-2050406-RO	2	28	107-02405	22	7
SM-6064002-TP	12	47	SS-6121860-SP	10	28				107-02553	22	2
SM-6065002-TP	4	76	SS-6122510-SP	8	80	WP-0320501-SC	14	10	107-02561	22	1
SM-8030402-TP	4	64	SS-6123010-SP	2	12	WP-0320501-SC	16	12	107-02603	22	4
SM-8030402-TP	12	12	SS-6151412-TP	6	14	WP-0320501-SC	22	25	107-02603	22	32
SM-8040502-TP	4	54	SS-6151412-TP	12	9	WP-0320501-SC	22	55	107-02702	22	21
SM-8040602-TP	23	2	SS-6151440-SP	38	6	WP-0320501-SC	28	60	107-02702	22	52
SM-8040602-TP	23	6	SS-6151440-SP	38	18	WP-0320501-SC	32	18	107-02801	22	22
SM-8040802-TP	14	21	SS-6152440-SP	6	10	WP-0371016-SD	26	19	107-02801	22	53
SM-8050502-TP	8	40	SS-6621220-SP	4	19	WP-0450000-SD	6	22	107-03106	22	26
SM-8050502-TP	16	32	SS-7060610-SP	14	5	WP-0450846-SP	37	16	107-03205	22	24
SM-8050502-TP	18	5	SS-7060610-SP	14	6	WP-0482086-SD	22	48	107-03205	22	47
SM-8050502-TP	18	29	SS-7060610-SP	16	4	WP-0501016-SC	30	47	107-03304	22	17
SM-8050502-TP	18	46	SS-7060610-SP	16	6	WP-0520656-SA	14	34	107-03452	23	13
SM-8050502-TP	20	6	SS-7080510-TP	8	6	WP-0520656-SA	16	8	107-03502	23	1
SM-8050502-TP	20	29	SS-7080510-TP	8	11	WP-0520656-SA	23	25	107-03601	23	3
SM-8050502-TP	20	46	SS-7090520-SP	2	25	WP-0531000-SE	36	31	107-03700	23	4
SM-8050602-TP	8	39	SS-7090910-TP	26	18	WP-0531001-SC	23	24	107-03809	23	14
SM-8050602-TP	8	41	SS-7110340-SP	23	27	WP-0621016-SD	36	29	107-03908	23	5
SM-8050602-TP	14	14	SS-7110510-SP	2	31	WP-0621016-SD	38	25	107-04005	23	19
SM-8050602-TP	18	60	SS-7110510-SP	2	41	WP-0641601-SD	18	52	107-04104	23	29
SM-8050602-TP	20	57	SS-7110510-SP	32	24	WP-0641601-SD	20	49	107-04153	23	28
SM-8050602-TP	23	21	SS-7110510-SP	37	27	WP-0641601-SD	38	23	107-04609	2	44
SM-8060552-TP	12	31	SS-7110710-SP	10	18	WP-0651056-SH	18	50	107-04757	4	6
SM-8060602-TP	4	9	SS-7110710-SP	36	21	WP-0651056-SH	23	8	107-04807	23	20
SM-8060602-TP	4	11	SS-7110810-SP	10	10	WP-0740516-SP	12	14	107-04955	4	8
SM-8060602-TP	4	33	SS-7110810-SP	23	9	WP-0841601-SC	28	75	107-04963	4	10
SM-8060602-TP	4	55	SS-7110910-SP	10	27	WP-1221016-SP	26	10	107-05002	4	12
SM-8060602-TP	10	26	SS-7110910-SP	37	19	WP-1612616-SE	33	38	107-05606	4	28
SM-8061212-TP	4	49	SS-7110910-SP	37	21	WP-1702600-SO	33	19	107-05606	4	30
SM-8080802-TP	4	7	SS-7110910-SP	37	25	WS-0410002-KN	37	15	107-05754	4	29
SM-8080802-TP	4	13	SS-7110910-TP	2	33	WS-0510002-KN	33	16	107-06315	4	53
SM-8080812-TP	4	3	SS-7112420-SP	6	6	WT-0530002-KS	2	39	107-06703	4	16
SM-9081050-SE	26	30	SS-7120710-SP	8	51	WT-0530002-KS	14	40	107-06802	4	63
SM-9081050-SE	28	74	SS-7120710-SP	30	51				107-07156	4	37
SQ-0000401-MZ	28	41	SS-7121410-TP	8	60	100-04109	14	51	107-07206	4	46
SQ-1110401-MZ	4	25	SS-7121610-SP	2	2	100-88003	23	30	107-07305	4	48

N U M E R I C A L I N D E X O F P A R T S

索引

PART NO 品番	PAGE 頁	REF NO	PART NO 品番	PAGE 頁	REF NO	PART NO 品番	PAGE 頁	REF NO	PART NO 品番	PAGE 頁	REF NO
107-07958	4	42	107-16009	24	2	107-23906	20	30	107-33103	2	43
107-08204	6	2	107-16108	24	17	107-24201	18	34	107-33509	10	25
107-08303	4	18	107-16207	24	18	107-24201	20	34	107-33608	28	61
107-08501	6	16	107-16306	24	10	107-24607	18	2	107-33707	28	62
107-08907	8	68	107-16504	8	59	107-24607	20	2	107-33806	6	20
107-09152	6	9	107-16603	24	15	107-24706	18	47	107-34119	28	64
107-09202	6	11	107-17106	34	11	107-24706	20	47	107-34309	28	68
107-09350	6	13	107-17106	44	22	107-24805	18	39	107-34606	28	58
107-09400	6	15	107-17205	44	23	107-24805	20	39	107-34853	32	4
107-09608	8	25	107-17304	44	24	107-25000	18	40	107-35801	36	26
107-09707	8	1	107-17502	12	1	107-25000	20	40	107-35868	36	25
107-09806	8	4	107-17668	12	2	107-25158	18	42	107-35900	37	6
107-09905	8	5	107-17809	12	4	107-25158	20	42	107-35959	37	5
107-09905	8	7	107-18005	12	24	107-25307	10	8	107-36007	37	11
107-10002	8	9	107-18005	12	32	107-25604	18	44	107-36403	38	2
107-10101	8	10	107-18153	12	25	107-25604	20	44	107-36601	38	15
107-10200	8	12	107-18153	12	33	107-25752	18	45	107-36908	26	31
107-10309	8	14	107-18203	12	16	107-25752	20	45	107-37013	26	35
107-10408	8	15	107-18302	24	13	107-25901	18	48	107-37104	30	3
107-10507	8	18	107-18351	24	5	107-25901	20	5	107-37203	30	49
107-10606	8	19	107-18401	10	31	107-26107	18	7	107-37302	38	12
107-10705	8	20	107-18500	12	43	107-26107	20	8	107-37401	36	27
107-10804	8	8	107-18658	12	8	107-26206	18	49	107-37500	37	17
107-10804	8	17	107-18906	12	11	107-26305	14	8	107-37609	37	20
107-10903	8	69	107-18906	38	8	107-26305	16	10	107-37708	37	22
107-10903	12	10	107-19052	12	18	107-26404	14	3	107-37807	37	24
107-10903	12	27	107-19219	12	20	107-26404	16	3	107-38755	37	26
107-10903	12	35	107-19300	12	23	107-26503	14	2	107-39001	44	25
107-11000	8	21	107-19508	12	28	107-26503	16	2	107-39209	28	10
107-11117	8	23	107-19672	12	21	107-26552	14	1	107-39209	28	35
107-11406	8	56	107-19706	12	19	107-26552	16	1	107-39308	18	23
107-11406	14	28	107-19805	12	29	107-26800	14	7	107-39308	20	23
107-11406	16	20	107-19979	12	30	107-26800	16	9	107-39407	18	24
107-11406	26	16	107-20019	12	36	107-26909	14	4	107-39407	20	24
107-11406	37	8	107-20209	10	1	107-26909	16	5	107-39506	8	70
107-11505	14	18	107-20407	10	7	107-27105	28	7	107-40611	30	24
107-11653	34	7	107-20555	10	5	107-27105	28	31	107-40710	30	50
107-11653	42	1	107-20605	10	13	107-27154	28	6	107-40801	30	40
107-11653	44	1	107-20704	10	12	107-27162	28	30	107-40900	32	2
107-11752	42	2	107-20803	10	14	107-27204	28	8	107-41007	4	14
107-11752	44	2	107-21009	10	19	107-27204	28	32	107-41106	22	16
107-11851	42	3	107-21207	10	34	107-27303	28	34	107-41106	22	45
107-11851	44	3	107-21306	10	16	107-27709	14	22	107-41452	22	6
107-11950	42	4	107-21504	10	9	107-27709	16	37	107-41452	22	34
107-11950	44	4	107-21702	10	17	107-27808	14	16	107-41502	22	20
107-12057	42	14	107-22007	10	23	107-27857	14	15	107-41601	22	13
107-12057	44	14	107-22353	18	26	107-27907	14	46	107-41759	14	39
107-12255	44	28	107-22353	20	26	107-28103	14	26	107-41759	36	36
107-12354	42	13	107-22403	18	1	107-28103	16	19	107-41908	30	36
107-12354	44	13	107-22551	18	53	107-28152	14	25	107-42005	32	5
107-12552	34	9	107-22551	20	50	107-28152	16	18	107-42203	36	8
107-12552	42	15	107-22601	18	62	107-28160	14	24	107-42302	32	1
107-12651	42	17	107-22601	20	59	107-28160	16	17	107-42708	2	10
107-12750	42	18	107-22700	18	68	107-28301	14	35	107-43003	2	7
107-12859	44	15	107-22700	20	65	107-28400	18	64	107-43151	2	1
107-12958	44	16	107-22809	18	72	107-28400	20	61	107-43300	24	1
107-13055	44	21	107-22809	20	69	107-28509	18	59	107-43805	10	33
107-13253	44	30	107-22908	18	69	107-28509	20	56	107-44308	10	24
107-13501	8	65	107-22908	20	66	107-28608	18	61	107-44506	38	17
107-13766	8	26	107-23013	18	57	107-28608	20	58	107-44704	22	8
107-13808	8	31	107-23013	20	54	107-28707	18	63	107-44803	22	9
107-13907	8	33	107-23104	18	66	107-28707	20	60	107-44902	22	11
107-14004	8	35	107-23104	20	63	107-28806	26	7	107-45354	42	5
107-14103	8	36	107-23203	18	58	107-29010	26	1	107-45354	44	5
107-14202	8	37	107-23203	20	55	107-29606	26	20	107-45453	42	6
107-14400	8	42	107-23302	18	70	107-29754	26	14	107-45453	44	6
107-14509	8	30	107-23302	20	67	107-29952	26	21	107-45552	42	7
107-14608	8	32	107-23401	18	71	107-30109	26	23	107-45552	44	7
107-14905	8	50	107-23401	20	68	107-30703	26	29	107-45651	42	8
107-15001	8	52	107-23500	18	67	107-31008	26	11	107-45651	44	8
107-15258	8	54	107-23500	20	64	107-31404	28	2	107-45800	2	40
107-15506	24	9	107-23708	18	27	107-31701	2	29	107-45909	4	20
107-15605	24	6	107-23708	20	27	107-32204	14	38	107-46352	42	9
107-15704	8	57	107-23807	18	28	107-32402	28	49	107-46352	44	9
107-15902	24	12	107-23807	20	28	107-32600	28	50	107-46451	42	10
107-15951	24	4	107-23906	18	30	107-33004	28	4	107-46451	44	10

NUMERICAL INDEX OF PARTS

索引

PART NO 品番	PAGE 頁	REF NO	PART NO 品番	PAGE 頁	REF NO	PART NO 品番	PAGE 頁	REF NO	PART NO 品番	PAGE 頁	REF NO
107-46550	42	11	107-73505	22	31	107-84254	40	74	229-33006	36	3
107-46550	44	11	107-73703	22	41	107-84502	40	75	231-51202	32	9
107-46659	42	12	107-73802	22	42	107-84551	40	1	231-51301	2	49
107-46659	44	12	107-74008	2	34	107-84601	40	76	231-51400	2	26
107-46709	12	5	107-74305	8	28	107-84650	40	2	231-51509	28	25
107-46907	28	78	107-74651	2	4	107-84700	40	77	231-51657	2	15
107-47111	28	27	107-75302	18	36	107-84759	40	3	231-51707	2	16
107-47350	44	17	107-75500	4	27	107-84809	35	2	231-52051	37	18
107-47459	44	18	107-75609	4	52	107-84809	40	78	231-52150	30	23
107-47558	44	19	107-75658	4	51	107-84858	40	4	231-52663	6	4
107-47657	44	20	107-75807	38	5	107-84908	40	79	231-52705	4	40
107-48002	4	57	107-75906	38	7	107-84957	40	5	231-52754	4	35
107-48101	32	17	107-76656	4	32	107-85004	40	80	231-52853	4	41
107-48358	44	29	107-76664	4	31	107-85053	40	6	231-52903	4	2
107-48507	30	25	107-76953	36	35	107-85103	40	81	231-53109	6	7
107-48804	30	26	107-77308	2	18	107-85152	40	7	231-53208	6	5
107-48903	30	35	107-77407	36	24	107-85202	40	82	231-53307	4	45
107-49109	30	27	107-77555	40	14	107-85251	40	8	231-53406	6	25
107-51303	8	38	107-77654	40	15	107-85301	40	83	231-53505	6	1
107-52202	18	55	107-77753	40	16	107-85350	40	9	231-53901	4	1
107-52202	20	52	107-77803	35	13	107-85400	40	84	231-54057	4	65
107-52301	18	56	107-77852	35	12	107-85459	40	10	231-54107	4	67
107-52301	20	53	107-77852	40	17	107-85509	40	85	231-54404	4	17
107-52418	18	65	107-77951	40	18	107-85558	40	11	231-54552	4	75
107-52418	20	62	107-78058	40	19	107-85608	40	86	231-54602	4	4
107-52467	18	54	107-78157	40	20	107-85657	40	12	231-54701	4	69
107-52467	20	51	107-78256	40	21	107-85707	40	87	231-54800	4	74
107-52707	30	41	107-78355	40	22	107-85756	40	13	231-55005	12	15
107-53002	28	11	107-78454	40	23	107-86002	35	4	231-55104	12	46
107-53002	28	36	107-78553	40	24	107-86002	40	93	231-55203	8	45
107-53150	34	13	107-78652	40	25	107-86101	40	94	231-55203	12	50
107-54505	14	19	107-78751	40	26	107-86200	40	95	231-55401	10	35
107-54604	14	48	107-79007	40	27	107-86309	40	88	231-55500	10	2
107-54802	4	38	107-79106	35	15	107-86408	35	5	231-55708	12	17
107-54901	2	42	107-79106	40	28	107-86408	40	89	231-55955	10	40
107-55007	32	23	107-80005	40	30	107-86507	40	90	231-56102	8	44
107-55155	32	20	107-80104	40	31	107-86606	40	91	231-56201	8	79
107-55205	32	19	107-80203	40	32	107-86903	40	56	231-56300	8	78
107-55403	28	38	107-80302	35	10	107-87000	40	57	231-56409	8	81
107-55502	26	27	107-80302	40	33	107-87109	40	58	231-56508	8	48
107-55601	18	6	107-80401	40	34	107-87208	40	59	231-56904	26	13
107-55601	20	7	107-80500	40	35	107-87307	40	60	231-57506	26	3
107-55700	2	22	107-80609	40	36	107-87406	40	61	231-57605	26	5
107-58456	42	16	107-80708	40	37	110-07101	8	29	231-58207	32	8
107-59603	18	73	107-80807	40	38	110-20401	4	22	231-58801	36	22
107-59603	20	70	107-80906	40	39	110-20500	4	24	231-58959	36	16
107-59603	36	12	107-81003	40	40	110-20609	4	23	231-59254	28	77
107-59603	36	13	107-81102	40	41	110-45101	22	44			
107-60304	28	20	107-81201	40	42	110-71800	26	17			
107-60502	28	84	107-81557	40	43	110-72402	22	43			
107-70303	18	25	107-81656	40	44	110-73103	36	11			
107-70352	18	4	107-81755	40	45	111-85105	33	35			
107-70402	18	22	107-81854	35	8	111-85204	33	27			
107-70402	20	22	107-81854	40	46	111-85501	33	31			
107-70501	18	43	107-81953	40	47	119-56703	22	36			
107-70501	20	43	107-82050	40	48	119-66504	33	34			
107-71251	4	36	107-82159	40	49	119-69508	33	36			
107-71301	28	23	107-82258	40	50	121-09500	26	40			
107-71509	28	18	107-82357	40	51	123-47308	36	5			
107-71707	20	25	107-82456	40	52	137-07500	12	39			
107-71756	20	4	107-82555	40	53						
107-71806	16	15	107-82654	40	54	210-54903	28	44			
107-71905	16	24	107-82753	40	55	211-24202	28	71			
107-72002	16	29	107-83058	40	62	226-03708	2	35			
107-72101	16	31	107-83157	40	63	229-30309	33	14			
107-72200	16	33	107-83256	40	64	229-30358	33	1			
107-72309	14	12	107-83355	35	6	229-30408	33	10			
107-72408	20	36	107-83355	40	65	229-30507	33	9			
107-72507	16	26	107-83454	40	66	229-30705	33	7			
107-72705	20	1	107-83553	40	67	229-30804	33	5			
107-72804	14	11	107-83652	40	68	229-30903	33	4			
107-72804	16	35	107-83751	40	69	229-31000	33	3			
107-73109	22	56	107-83850	40	70	229-31109	33	2			
107-73356	22	30	107-83959	40	71	229-31208	33	15			
107-73364	22	29	107-84056	40	72	229-31307	33	11			
107-73406	22	46	107-84155	40	73	229-31406	33	8			

**JUKI®**

JUKI 株式会社

JUKI CORPORATION

お問い合わせ、ご相談は  
To order or for further  
information,  
please contact:

Copyright © 2000 JUKI CORP.  
本書の内容を無断で転載、複写すること  
を禁止します。  
All rights reserved throughout the world.

※このパーツリストは商品改良のため予告なく変更する事があります。  
\*The description covered in this parts list is subject to change for improvement of the commodity without notice.  
※このパーツリストは、2000年1月 現在の商品仕様で編集したものです。  
\*This parts list is edited in accordance with the product specifications as of January 2000.

2000. 3. Printed in Japan (E)