

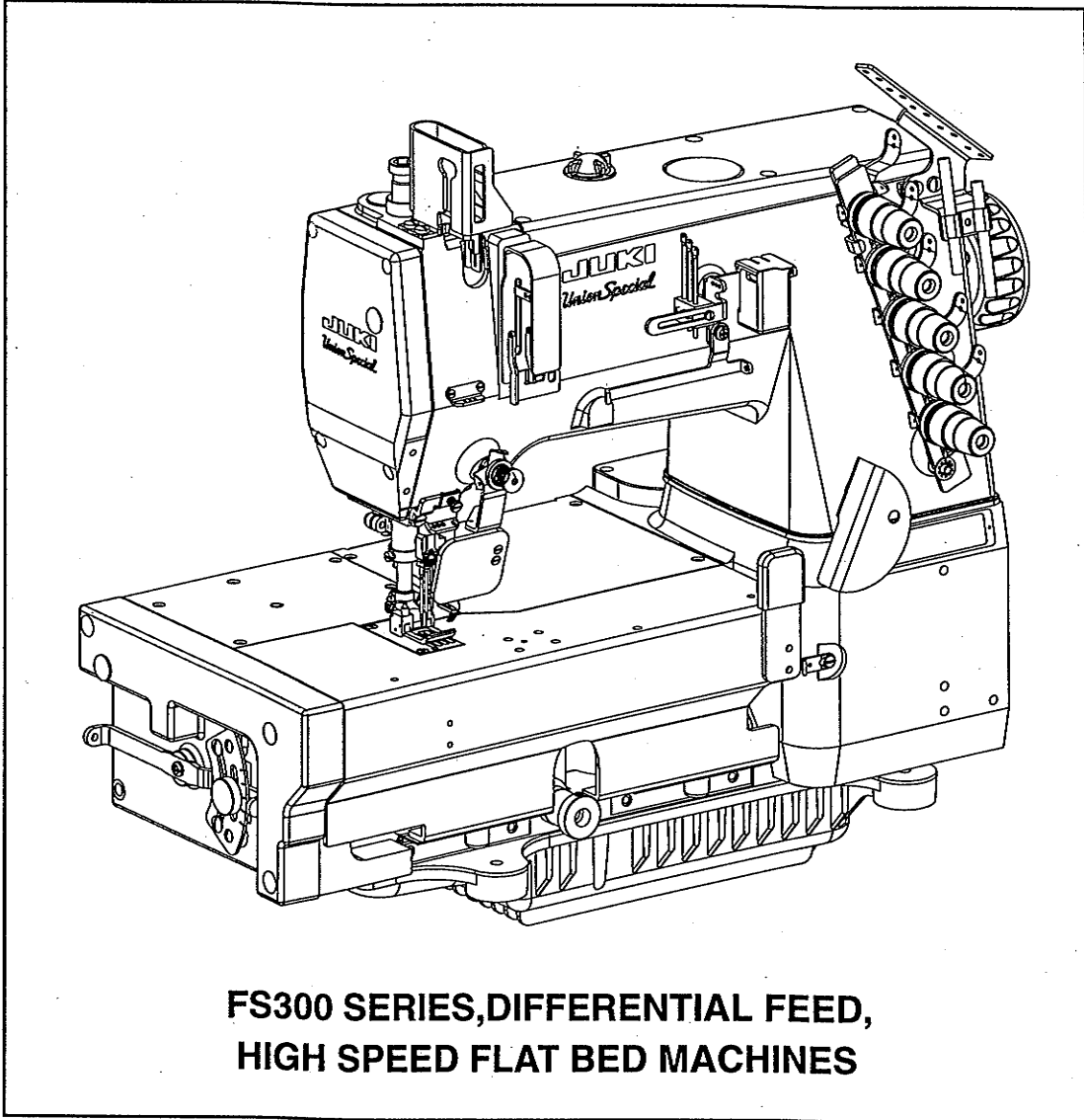

# Union Special

INDUSTRIAL SEWING EQUIPMENT

## ADJUSTING INSTRUCTIONS/ ILLUSTRATED PARTS LIST



**FS300 SERIES, DIFFERENTIAL FEED,  
HIGH SPEED FLAT BED MACHINES**

**MANUAL NO. PT9623**

**FOR DEVICE**

**CC1FS3**

**CC2FS3**

**CC2AFS3**

MAY 5 2004



Parts Manual PT9623  
for Devices CC1FS3, CC2FS3

Third Edition Copyright 1998 by Union Special Corporation  
Rights Reserved In All Countries Printed in U.S.A. Sept 1998

---

---

PREFACE

This parts manual has been prepared to assist you in locating individual parts or assemblies on FS300 Machines. It can be used in conjunction with Union Special Parts Manual's PT9605, PT9635, Operator's Manuals OP9606, OP9614 and Engineer's Manual EN9424. Depending on application.

It is the desire of Union Special that each machine run at its optimum performance. Parts listed in this manual are designed specifically for your machine and are manufactured with utmost precision to assure long lasting service.

This manual has been comprised on the basis of available information. Changes in design and/or improvements may incorporate a slight modification of configuration in illustrations or part numbers.

On the following pages are illustrations and terminology used in describing the parts used on FS300 Series machines.

---

---

CONTENTS

•SAFETY RULES .....	3
•CHAIN CUTTER ADJUSTMENTS .....	4
•KNIFE SHARPENING .....	4
•SETTING KNIFE CROSS OVER .....	5
•SHEAR ANGLE .....	5
•SETTING PRESSURE VALVES .....	5
•REASSEMBLING .....	5
•PNEUMATIC CHAIN CUTTER ASSEMBLY .....	7
•MISCELLANEOUS COVERS .....	9
•PNEUMATIC CONTROL ASSEMBLY .....	11



## SAFETY RULES

1. Before putting the machines described in this manual into service, carefully read the instructions. The starting of each machine is only permitted after taking notice of the instructions and by qualified operators.

**IMPORTANT!** Before putting the machine into service, also read the safety rules and instructions from the motor supplier.

2. Observe the national safety rules valid for your country.
3. The sewing machines described in this instruction manual are prohibited from being put into service until it has been ascertained that the sewing units which these sewing machines will be built into, have conformed with the EC Council Directives (89/392/EEC, Annex II B).

Each machine is only allowed to be used as foreseen. The foreseen use of the particular machine is described in paragraph "STYLES OF MACHINES" of this instruction manual. Another use, going beyond the description, is not as foreseen.

4. All safety devices must be in position when the machine is ready for work or in operation. Operation of the machine without the appertaining safety devices is prohibited.
5. Wear safety glasses.
6. In case of machine conversions and changes all valid safety rules must be considered. Conversions and changes are made at your own risk.
7. The warning hints in the instructions are marked with one of these two symbols:

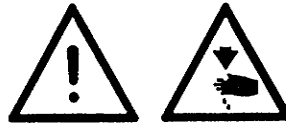

8. When doing the following the machine has to be disconnected from the power supply by turning off the main switch or by pulling out the main plug:
  - 8.1 When threading needle(s), looper, spreader etc.
  - 8.2 When replacing any parts such as needle(s), presser foot, throat plate, looper, spreader, feed dog, needle guard, folder, fabric guide etc.
  - 8.3 When leaving the workplace and when the workplace is unattended.
  - 8.4 When doing maintenance work.
  - 8.5 When using clutch motors without actuation lock, wait until the motor is stopped totally.
9. Maintenance, repair and conversion work (see item 8) must be done only by trained technicians or special skilled personnel under consideration of the instructions.
10. Any work on the electrical equipment must be done by an electrician or under direction and supervision of special skilled personnel.
11. Work on parts and equipment under electrical power is not permitted. Permissible exceptions are described in the applicable sections of standard sheet DIN VDE 0105.
12. Before doing maintenance and repair work on the pneumatic equipment, the machine has to be disconnected from the compressed air supply. In case of existing residual air pressure, after disconnecting from compressed air supply (i.e. pneumatic equipment with air tank), the pressure has to be removed by bleeding.

# CHAIN CUTTER ADJUSTMENTS

## KNIFE SHARPENING

Remove suction cover, filter cover plate and the inlets. Remove the upper knife (A, Fig. 1) by loosening two screws (B) sharpen if necessary. Remove the lower knife (F) by unhooking the knife spring (E) and sliding the lower knife forward and up, sharpen if necessary. Replace the knives in the reverse manner.

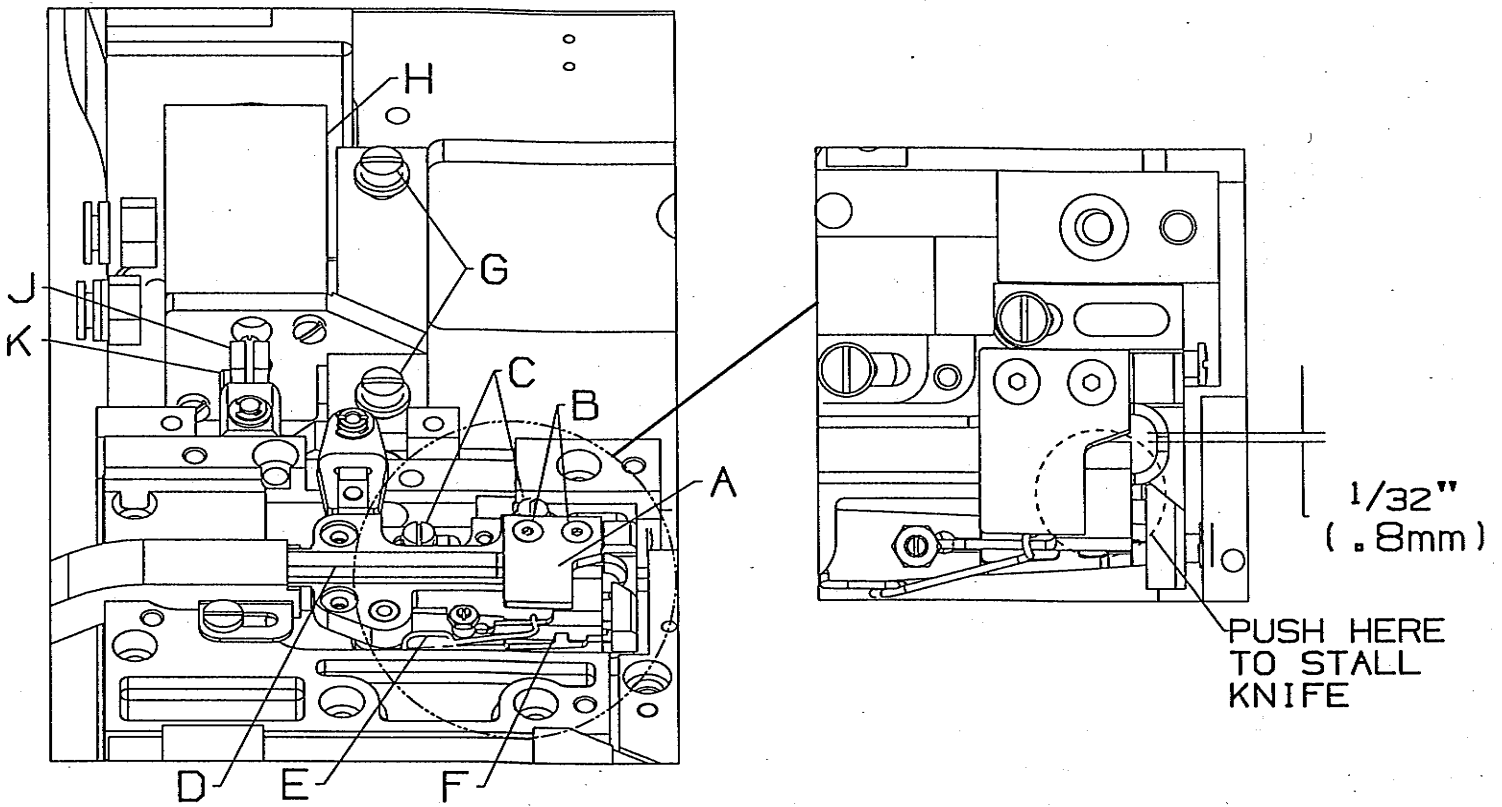
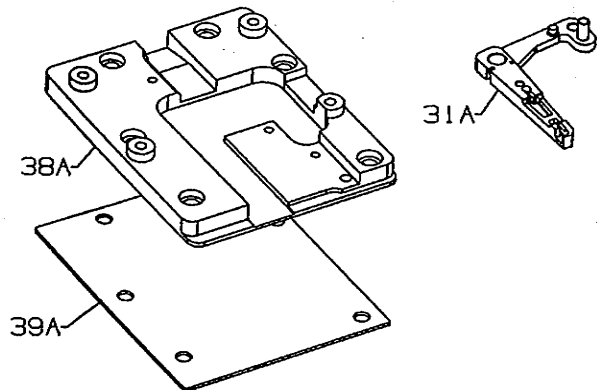
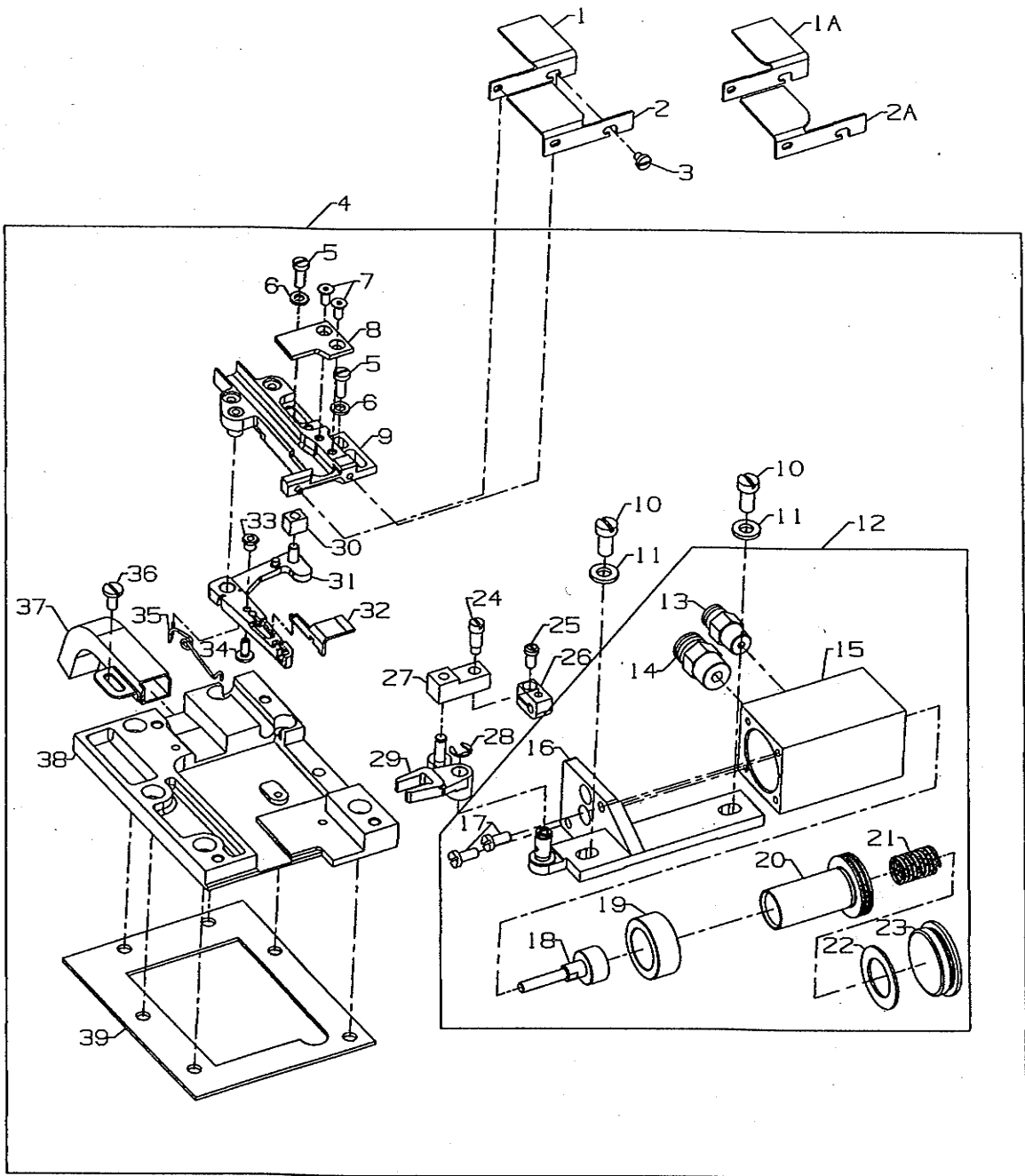

FIG 1





# PNEUMATIC CHAIN CUTTER ASSEMBLY

Ref. No.	Part No.	Description	Amt. Req.
1.	99677TCB	Inlet For single needle machines .....	1
1A.	99677TCD	Inlet For multi needle machines .....	1
2.	99677TCC	Adjustable inlet For single needle machines .....	1
2A.	99677TCE	Adjustable inlet For multi needle machines .....	1
3.	28	Screw .....	1
4.	V29944F	Pneumatic Chain Cutter Assembly, for CC1FS3 device .....	1
-	29941AAL	Pneumatic Chain Cutter Assembly, for CC2FS3 device .....	1
5.	22729J	Screw .....	2
6.	80265	Washer .....	2
7.	95435A	Screw .....	2
8.	99670TH	Stationary Knife .....	1
9.	99691TA	Air Clip Housing .....	1
10.	22517	Screw .....	2
11.	80557	Washer .....	2
12.	671H4	Air Motor Assembly .....	1
13.	671F82A	Male Connection .....	1
14.	671F78	Straight Fitting .....	1
15.	671H2A	Housing .....	1
16.	671H4A	Bracket, Housing .....	1
17.	22585	Screw .....	2
18.	50322BP	Shaft, Air Motor .....	1
19.	50335BK	Air Motor Spacer .....	1
20.	671H1A	Piston .....	1
21.	660-753	Spring .....	1
22.	671H1F	Washer, Bumper .....	1
23.	671H1D	Screw, Plug .....	1
24.	86X	Screw .....	1
25.	22562A	Screw .....	1
26.	50355AT	Binder, Air Motor .....	1
27.	50335BJ	Link, Air Motor .....	1
28.	96275	Retaining Ring .....	1
29.	99672UD	Drive Lever .....	1
30.	99672UE	Slider Block .....	1
31.	99666TA	Knife Lever, for CC1FS3 device .....	1
31A.	99666TB	Knife Lever, for CC2FS3 device .....	1
32.	99669TH	Moving Knife .....	1
33.	99322A	Adjusting Knife .....	1
34.	99372A	Adjusting Screw .....	1
35.	99697TA	Spring .....	1
36.	22585A	Screw .....	1
37.	99676UA	Suction Tube .....	1
38.	50382HN	Cover, for CC1FS3 device .....	1
38A.	50682C	Cover, for CC2FS3 device .....	1
39.	50684	Gasket, for CC1FS3 device .....	1
39A.	50382CS	Gasket, for CC2FS3 device .....	1



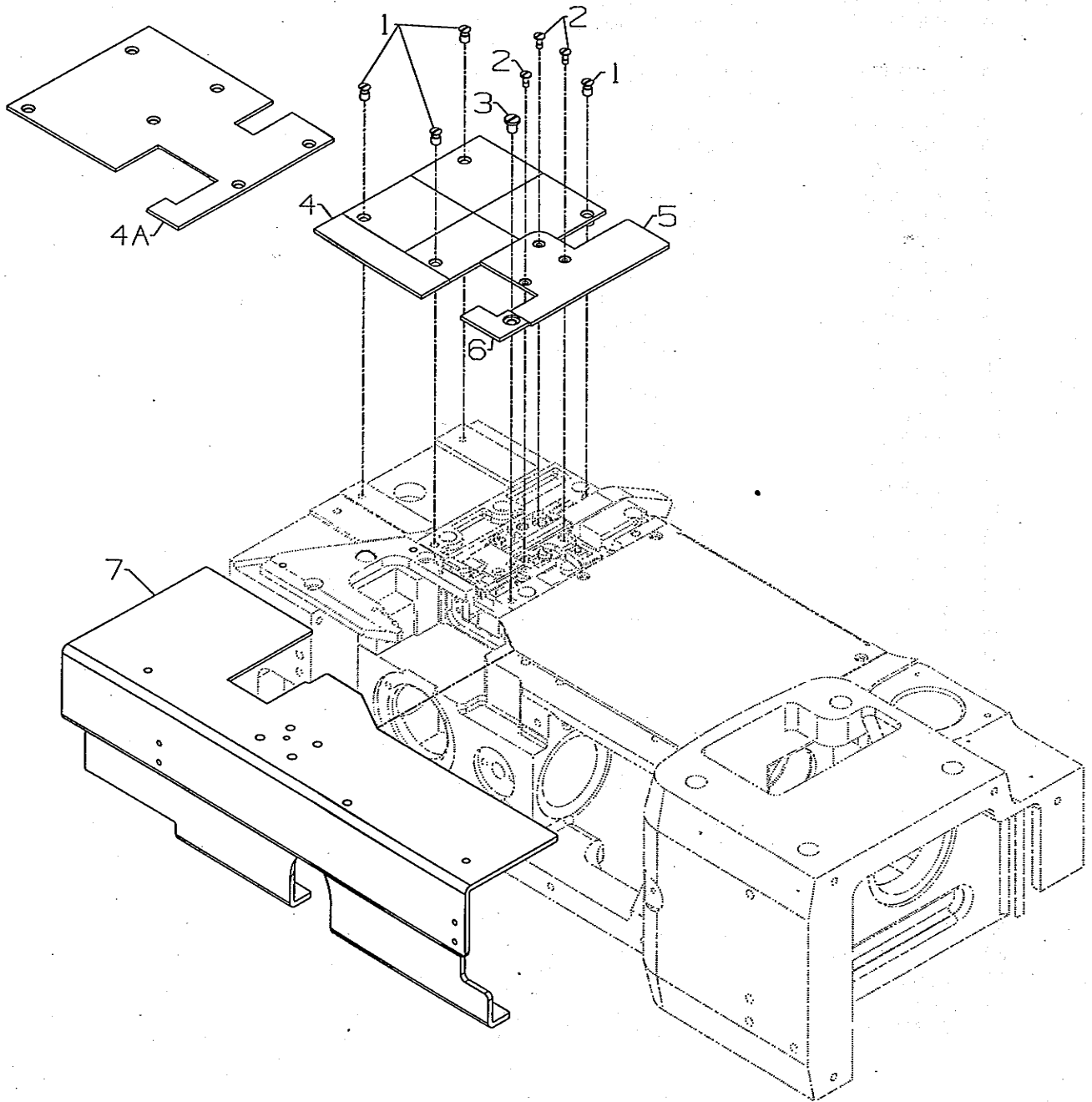



## MISCELLANEOUS COVERS

Ref. No.	Part No.	Description	Amt. Req.
1.	18-1448	Screw, for covers .....	4/6
2.	99312A	Screw, for chain cover .....	3
3.	SS6120620TP	Screw .....	1
4.	50301BV	Cloth Plate, for CC1FS3 device .....	1
4A.	50601G	Cloth Plate, for CC2FS3 device .....	1
5.	50382JC	Suction Cover, for CC1FS3 device .....	1
6.	50382HB	Cover Filler Plate, for CC1FS3 device .....	1
7.	50382CK	Front Cover, for CC1FS3 device .....	1



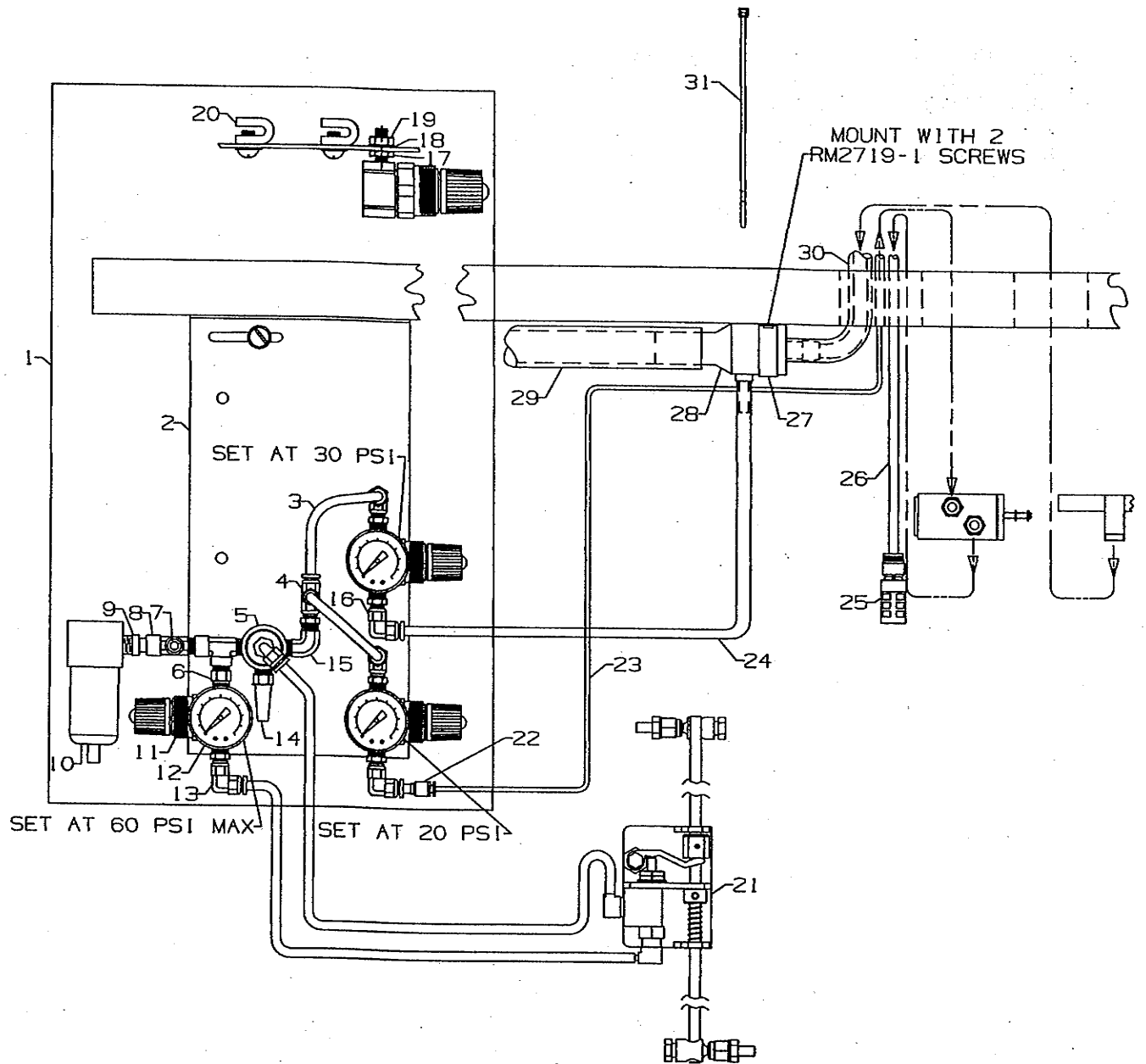

# PNEUMATIC CONTROL ASSEMBLY

Ref. No.	Part No.	Description	Amt. Req.
1.	29480ADM	Pneumatic Control Assembly .....	1
2.	35032R	Mounting Bracket .....	1
3.	660-392	Tubing .....	2
4.	671F94	Tubing .....	1
5.	RM4098-1	Pilot Valve .....	1
6.	RM3287-2	Hex Nipple .....	1
7.	22571F	Plug Screw .....	1
8.	RM2850D	Pipe Tee .....	2
9.	RM3320-1	Reducer .....	1
10.	671D5	Filter .....	1
11.	671D9	Regulator .....	3
12.	671D15	Gauge .....	3
13.	671F69	Tube Fitting .....	5
14.	660-403	Muffler .....	1
15.	RM2881-1	Elbow .....	1
16.	671F3	Male Elbow .....	1
17.	671C16	Mounting Stud .....	3
18.	652B20	Washer .....	3
19.	11635B	Nut .....	3
20.	661-3	Mounting Clamp .....	2
21.	29480ARN	Treadle Valve Assembly .....	1
22.	671F82H	Reducer .....	1
23.	671B37A	Tubing .....	1
24.	671B3	Venturi Supply Tube .....	1
25.	671F242	Silencer .....	1
26.	671B120	Tubing .....	1
27.	998-332	Venturi Holder .....	1
28.	671D2	Venturi .....	1
29.	671B11	Discharge Tube .....	1
30.	671B12	Suction Tube .....	1
31.	RM2871B	Wire Ties .....	4



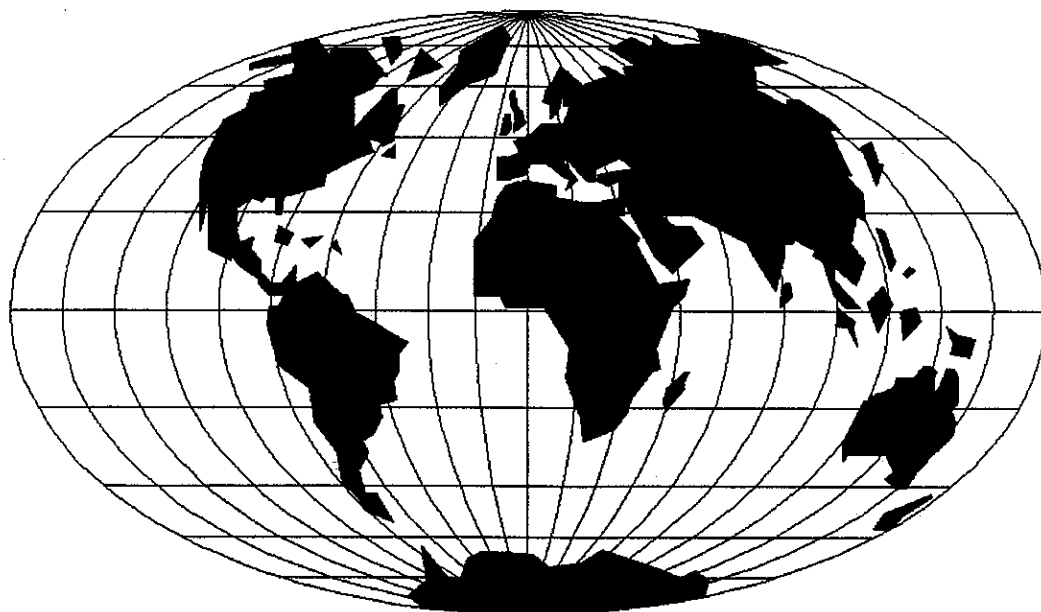

## WORLDWIDE SALES AND SERVICE

Union Special Corporation maintains sales and service facilities throughout the world. These offices will aid you in the selection of the right sewing equipment for your particular operation. Union Special Corporation representatives and service technicians are factory trained and are able to serve your needs promptly and efficiently. Whatever your location, there is a qualified representative to serve you.

---

Brussels, Belgium  
Charlotte, N.C.  
El Paso, TX  
Hong Kong, China  
Huntley, IL  
Leicester, England  
Lille, France  
Miami, FL  
Milan, Italy  
Möglingen, Germany  
Montreal, Quebec  
Osaka, Japan  
Santa Fe Springs, CA

Other Representatives throughout  
all parts of the world.



*Union Special*  
INDUSTRIAL SEWING EQUIPMENT