

**CATALOG NO. G285CD**  
**KATALOG NR. G285CD**

Supplement to Catalog No. G285  
 Zusatz zu Katalog Nr. G285  
**MACHINE CLASS**  
**MASCHINENKLASSE**

MACHINE STYLE

**80800CD** Two needle independent row, double locked stitch sewing machine with mechanically driven thread chain cutter for closing filled bags and sacks made of jute, cotton, paper, plastic or woven polypropylene tapes as well as bituminized or foil laminated materials.

Stitch type:	401 (acc. to ISO 4915)
Needle distance:	7,2 mm /18 ga, needles staggered, rear needle below
Capacity under pressure foot:	up to 16 mm (5/8 in.)
Sewing capacity on paper bags:	up to 32 plies of paper
Standard recommended needle type:	9848 G 250/100
Stitch range:	6,5 to 12 mm (2 1/8 to 4 SPI)
Standard Setting:	10 mm (2 1/2 SPI)
Working dia. of handwheel:	108 mm ( 4 1/4 in.)
Speed:	up to 1800 stitches per minute, depending on stitch length and conveyor speed as well as on fabric and sewing operation.
Equivalent continuous A-weighted sound pressure level at workstations at the operating speed 1400 rpm with column 20600:	84 dB(A), measurement acc. to ISO 10821, DIN 45 635 T48
Weight net:	30 kg

MASCHINENTYP

**80800CD** Zweinadel-Zweilini-Doppelkettenstich-Nähmaschine mit mechanisch angetriebenem Fadenkettenabschneider zum Schließen gefüllter Säcke und Beutel aus Jute, Baumwolle, Papier, Kunststoffolie oder Kunststoffbändchengewebe sowie bitumen- oder folienkaschiertem Material.

Nähstichtyp:	401 (nach ISO 4915)
Nadelabstand:	7,2 mm, Nadeln versetzt, hintere Nadel unten
Durchgang unter dem Drückerfuß:	bis 16 mm
Vernähbarkeit bei Papiersäcken:	bis 32 Lagen Papier
Empfohlener Standardnadeltyp:	9848 G 250/100
Stichlänge:	6,5 bis 12 mm
Standardstichlänge:	10 mm
Wirksamer Handrad-Durchmesser:	108 mm
Drehzahl:	bis 1800 Stiche/ Min., je nach Stichlänge und Transportgeschwindigkeit, sowie Material und Nähoperation
Arbeitsplatzbezogener Emissionswert bei Betriebsdrehzahl 1400 1/min. mit Säule 20600:	84 dB (A), Messung nach ISO 10821, DIN 45 635 T48
Gewicht netto:	30 kg

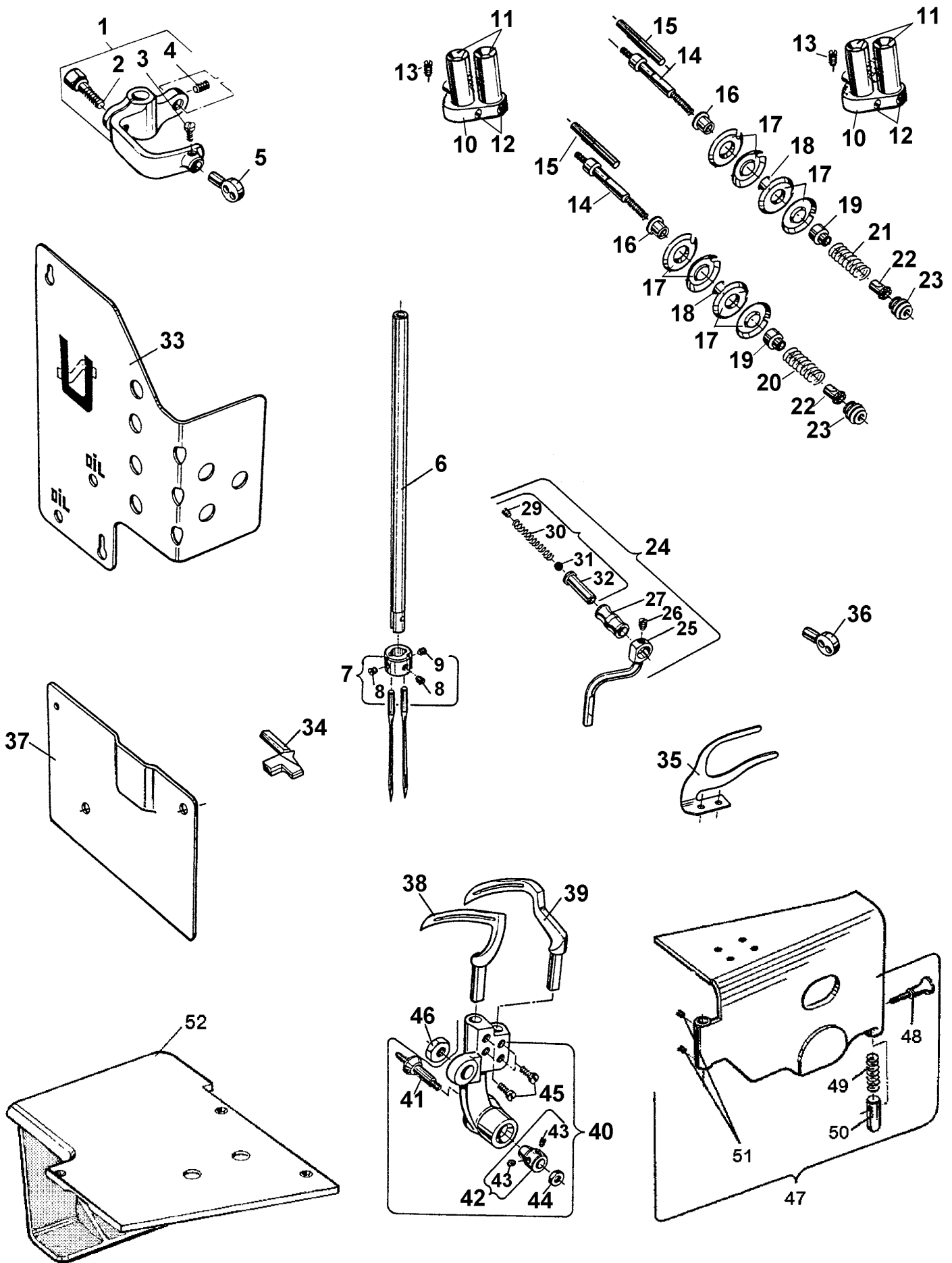

<u>Ref. No.</u>	<u>Part No.</u>	<u>Description</u>	<u>Beschreibung</u>	<u>Amt. req.</u>
<u>Pos. No.</u>	<u>Teil Nr.</u>			<u>Anzahl</u>
1	80659A	Needle Bar Connection	Nadelstangenmitnehmer	1
2	BP108	Screw	Schraube	1
3	22564D	Screw	Schraube	1
4	22894Y	Set Screw	Gewindestift	1
5	A10445	Needle Thread Eyelet	Nadelfadenöse	1
6	A 8374	Needle Bar	Nadelstange	1
7	A 8373	Needle Clamp Collar	Nadelring	1
8	88	Set Screw for Needle	Gewindestift für Nadel	2
9	89	Spot Screw, Headless	Gewindestift mit Spitze	1
10	AS 137C	Bracket	Halter	2
11	81256	Thread Sleeve	Fadenhülse	4
12	28 C	Set Screw	Gewindestift	4
13	22560B	Set Screw	Gewindestift	2
14	A10440	Tension Post	Spannungsbolzen	2
15	80655A	Pin for Tension Discs	Stift für Spannungsscheiben	2
16	A10441	Tension Post Ferrule	Hülse für Spannungsbolzen	2
17	80676A	Tension Disc	Spannungsscheibe	8
18	A10442	Spacer	Distanzscheibe	2
19	HA 1349	Tension Sleeve	Federhülse	2
20	110-4	Spring for Needle Thread Tension	Feder für Nadelfadenspannung	1
21	110-3	Spring for Looper Thread Tension	Feder für Greiferfadenspannung	1
22	107	Tension Spring Ferrule	Spannungs-Federhülse	2
23	108	Tension Nut	Spannungsmutter	2
24	81365 A	Needle Thread Take-up Roller Guide Assembly	Nadelführungsabzugsrollenführung komplett	1
25	81365	Roller Support	Rollenhalter	1
26	88	Set Screw	Gewindestift	1
27	80668 A	Thread Guide Roller	Fadenführungsrolle	1
28	81386	Roller Stud Assembly	Rollenbolzen komplett	1
29	22560	Set Screw	Gewindestift	1
30	HA1286B	Spring	Feder	1
31	12964 C	Spring Ball	Federkugel	1
32	81386 A	Roller Stud	Rollenbolzen	1
33	80687 B	Cover Plate	Abschlußblech	1
34	80825 RD	Needle Guard	Nadelanschlag	1
35	80804 RD	Looper Thread Cast-off Hook	Greiferfadenabzugshaken	1
36	81254 A	Looper Thread Eyelet	Greiferfadenöse	1
37	A10411	End Cover	Abschlußblech	1
38	A 8375	Looper, Front	Greifer, vorn	1
39	A 8376	Looper, Back	Greifer, hinten	1
40	A 8377 A	Looper Rocker	Greiferhebel	1
41	15745 B	Cone Stud	Kegelbolzen	1
42	15465 F	Cone	Kegelring	1
43	88 B	Set Screw	Gewindestift	2
44	12987 A	Nut	Mutter	1
45	73 X	Screw for Looper	Schraube für Greifer	4
46	12982	Nut	Mutter	1
47	A10409B	Hinge Cover Assembly	Scharnierplatte komplett	1
48	80440	Locking Bolt Knob	Griffschraube für Rastbolzen	1
49	80438	Spring	Feder	1
50	81239	Locking Bolt	Rastbolzen	1
51	89	Set Screw	Gewindestift	2
52	A10443	Cloth Plate	Stoffplatte	1

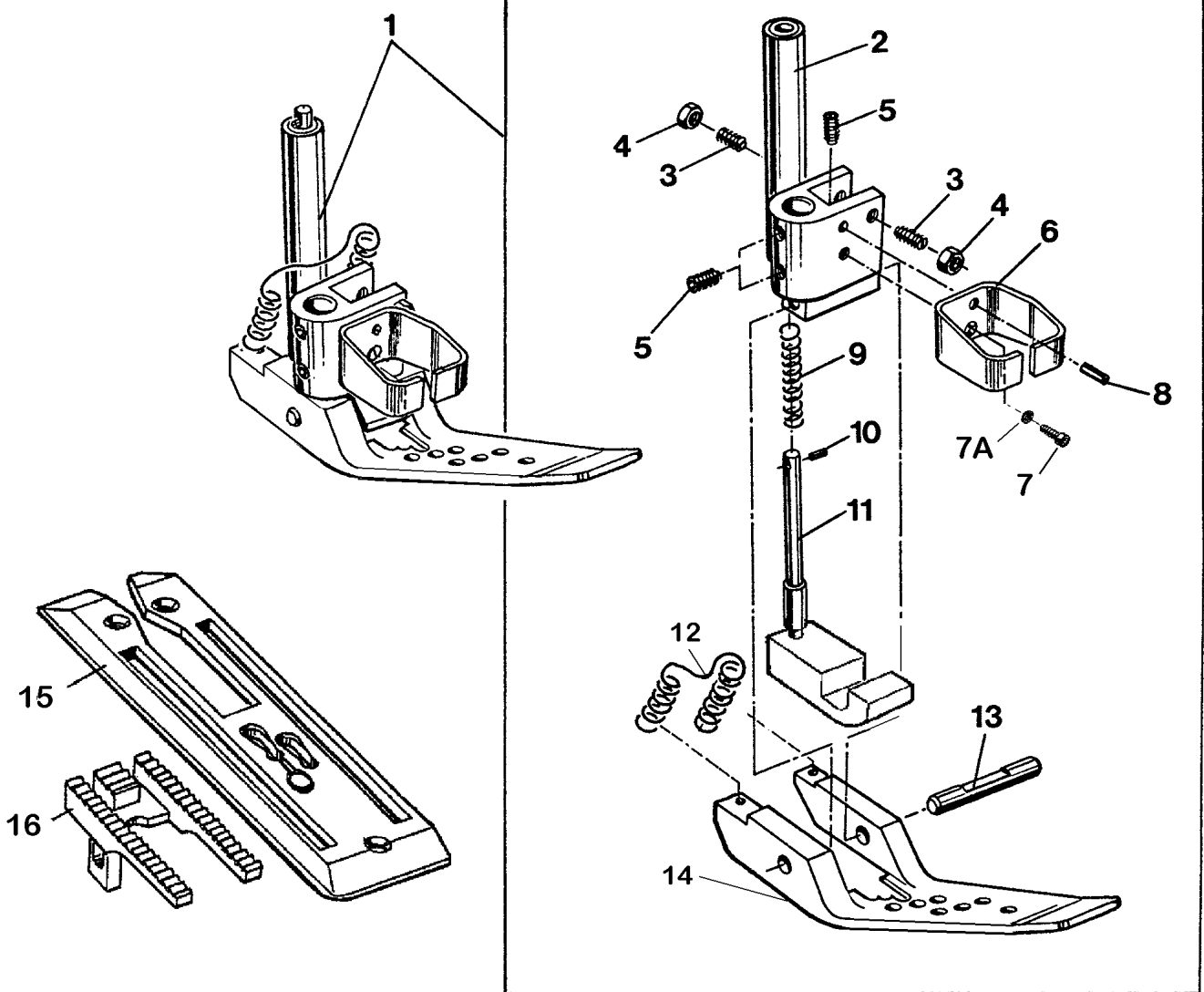

<u>Ref. No.</u>	<u>Part No.</u>	<u>Description</u>	<u>Beschreibung</u>	<u>Amt. req.</u>
<u>Pos. No.</u>	<u>Teil Nr.</u>			<u>Anzahl</u>
1	A10444	Presser Foot	Drückerfuß	1
2	80830	Presser Foot Shank	Drückerfußsnabe	1
3	22560A	Set Screw	Gewindestift	2
4	12934A	Nut	Mutter	2
5	22894C	Set Screw	Gewindestift	3
6	99682VD	Finger Guard	Fingerschutz	1
7	95686	Screw	Schraube	1
7A	97165A	Lock Washer	Sicherungsscheibe	1
8	96667	Clamping Sleeve	Spannhülse	1
9	80620G	Spring	Feder	1
10	80620H	Clamping Sleeve	Spannhülse	1
11	80620O	Chaining Section	Kettelfuß	1
12	80620 P	Spring	Feder	1
13	96521	Pin	Stift	1
14	A10444A	Presser Foot Bottom	Drückerfußsohle	1
15	80824CD	Throat Plate	Stichplatte	1
16	80705CD	Feed Dog	Transporteur	1

THREADING DIAGRAM  
EINFÄDELANLEITUNG

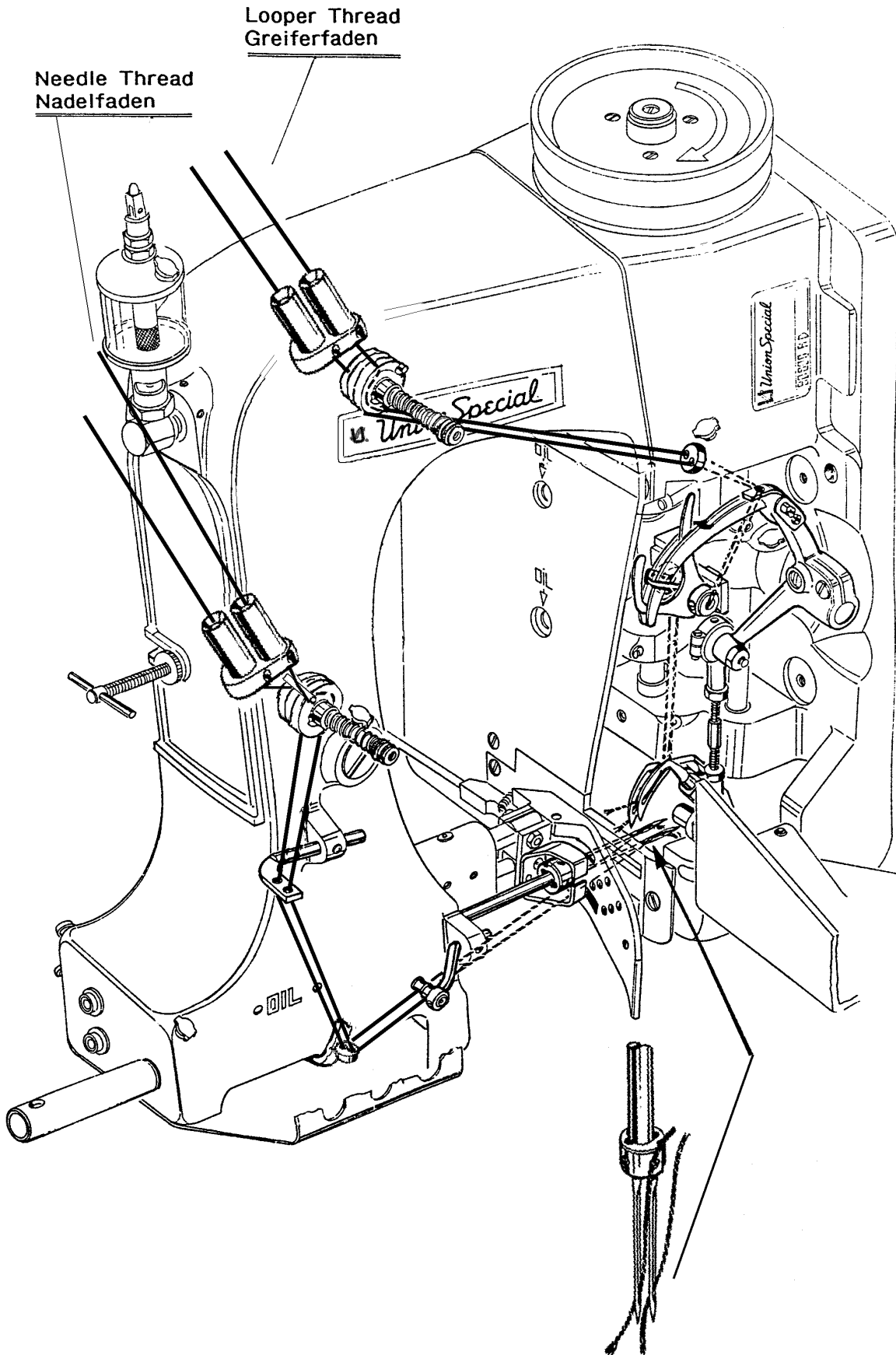

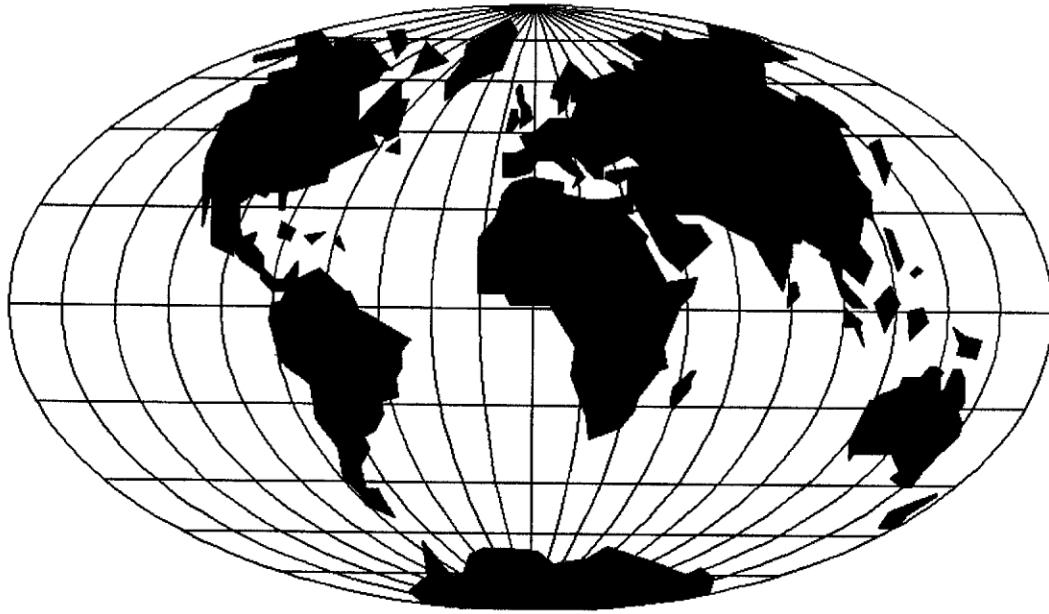

WORLDWIDE SALES AND SERVICE  
WELTWEITER VERKAUF UND KUNDENDIENST

Union Special maintains sales and service facilities throughout the world. These offices will aid you in the selection of the right sewing equipment for your particular operation. Union Special representatives and service technicians are factory trained and are able to serve your needs promptly and efficiently. Where ever your location, there is a qualified representative to serve you.

Union Special unterhält Verkaufs- und Kundendienst-Niederlassungen in der ganzen Welt. Diese helfen Ihnen in der Auswahl der richtigen Maschine für Ihren speziellen Bedarf. Union Special Vertreter und Kundendiensttechniker sind in unseren Werken ausgebildet worden, um Sie schnell und fachmännisch zu bedienen.

 **Union Special**<sup>®</sup>  
Finest Quality