

**SECOND
EDITION**

Union Special
INDUSTRIAL SEWING EQUIPMENT

CATALOG NO. 103N

STYLES

39500J

39500K

39500L

39500M

39500 CLASS

STREAMLINED

HIGH SPEED SERGERS

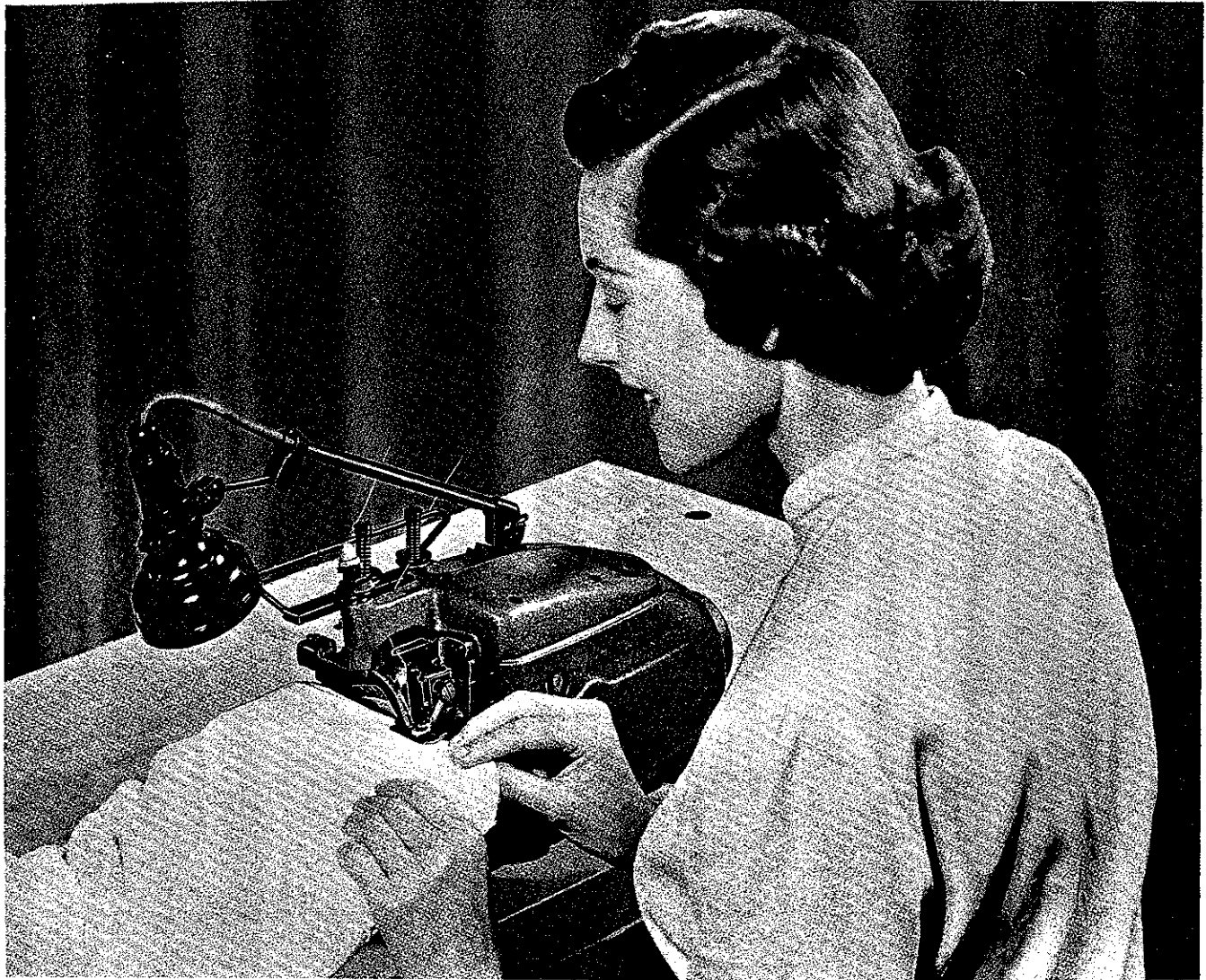

Your operators, too, will be pleased with the smooth, easy, trouble-free operation of the Thirty-Nine-Five. They will also like the other modern high-speed Union Specials available for all types of sewing operations. (Please see inside back cover)

Catalog No. 103 N

INSTRUCTIONS

FOR

ADJUSTING AND OPERATING

LIST OF PARTS

CLASS 39500

Styles

39500 J	39500 K
39500 L	39500 M

Second Edition

Copyright 1954

By

Union Special Machine Co.

Rights Reserved in All Countries

Union Special
INDUSTRIAL SEWING MACHINES
MACHINE COMPANY
CHICAGO

Printed in U. S. A.

May, 1973

FOREWORD

The Class 39500 machine is Union Special's latest overedger. New streamlined styling, automatic lubrication, and light running high speed performance are characteristics of these machines. All parts are made by precision methods insuring complete interchangeability.

It is our constant aim to furnish carefully prepared information that will enable the customer to secure all possible advantages from the use of Union Specials. The following pages contain valuable operating and adjusting data, and illustrate and describe the parts for Styles in Class 39500.

Union Special representatives will be found in all manufacturing centers, anxious to cooperate with you to plan and estimate requirements.

Union Special MACHINE COMPANY

Engineering Department

IDENTIFICATION OF MACHINES

Each Union Special machine carries a Style number which is stamped in the name plate on the machine. Style numbers are classified as standard and special. Standard Style numbers have one or more letters suffixed, but never contain the letter "Z". Example: "Style 39500 J". Special Style numbers contain the letter "Z". When only minor changes are made in a standard machine, a "Z" is suffixed to the standard Style number. Example: "Style 39500 JZ".

Styles of machines similar in construction are grouped under a Class number, which differs from the Style number in that it contains no letters. Example: "Class 39500".

APPLICATION OF CATALOG

This catalog applies specifically to the standard Styles of machines as listed herein. It can also be applied with discretion to some special machines in Class 39500. All references to directions, such as right and left, front and back, etc., are taken from the operator's position while seated at the machine. Operating direction of handwheel is away from operator.

STYLES OF MACHINES

Single Curved Blade Needle, One Looper, One Spreader, Two Thread, Serging Machine, Plain Feed, Trimming Mechanism with Spring Pressed Lower Knife, Automatic Lubricating System.

39500 J Plain feed machine for serging and trimming light, medium and heavy weight trousers and similar garments. Two thread stitch machine. Seam specification, 503-EFd-1; standard seam width, 3/16 inch; stitch range, 4-8 per inch; throw-out edge guide.

39500 K Plain feed machine for serging light, medium and heavy weight trousers and similar garments. The sewing combination does not permit trimming. Two thread stitch machine. Seam specification, 503-EFd-1; standard seam width, 3/16 inch; stitch range, 4-8 per inch; stationary edge guide.

Single Curved Blade Needle, Two Looper, Three Thread, Serging Machine, Plain Feed, Trimming Mechanism with Spring Pressed Lower Knife, Automatic Lubricating System.

39500 L Plain feed machine for serging and trimming light, medium and heavy weight trousers and similar garments. Three thread stitch machine. Seam specification, 505-EFd-1; standard seam width, 3/16 inch; stitch range, 4-8 per inch; throw-out edge guide.

39500 M Plain feed machine for serging light, medium and heavy weight trousers and similar garments. The sewing combination does not permit trimming. Three thread stitch machine. Seam specification, 505-EFd-1; standard seam width, 3/16 inch; stitch range, 4-8 per inch; stationary edge guide.

OILING

CAUTION! Oil was drained from machine when shipped, so reservoir must be filled before beginning to operate. Oil capacity of Class 39500 is six ounces. A straight mineral oil of a Saybolt viscosity of 90 to 125 seconds at 100° Fahrenheit should be used.

Machine is filled with oil at spring cap in top cover. Oil level is checked at sight gauge on front of machine. Red bulb on the oil level indicator should show between gauge lines when machine is stationary.

Machine is automatically lubricated. No oiling is necessary, other than keeping main reservoir filled. Check oil daily before the morning start; add oil as required.

Drain plug screw is located at back of machine near bottom edge of base.

NEEDLES

Each Union Special needle has both a type number and a size number. The type number denotes the kind of shank, point, length, groove, finish and other details. The size number, stamped on needle shank, denotes the largest diameter of blade, measured in thousandths of an inch midway between the shank and the eye. Collectively, type number and size number represent the complete symbol.

These machines use a curved blade needle. Standard needle for Styles 39500 J, K, L and M is Type 154 GAS. It is a round shank, round point, curved blade, standard length, single groove, struck groove, spotted, chromium plated and is available in sizes 022, 025, 027, 029, 032, 036, 040, 044, 049, 054, 060.

To have needle orders promptly and accurately filled, the empty package, a sample needle, or the type and size number should be forwarded. Use description on label. A complete order would read: "1000 Needles, Type 154 GAS, Size 044".

Selection of proper needle size is determined by the size of thread used. Thread should pass freely through needle eye in order to produce a good stitch formation.

Success in the operation of these machines can be secured only with genuine Union Special needles, which are packaged with labels marked *Union Special*. Each trademark is your guarantee of needles of the highest quality in materials and workmanship.

CHANGING NEEDLES

Release pressure on presser foot by turning presser foot release bushing (P, Fig. 1) and swing presser arm (G) out of position. Turn handwheel in operating direction until needle is at its lowest point of travel. Using hexagonal socket wrench No. 21388 AU, furnished with machine, loosen needle clamp nut about 1/4 turn. Again turn handwheel until needle is at high position; withdraw needle.

To replace needle, leave needle holder at high position and, with the flat to the left, insert needle in holder until it rests against stop pin. Keeping needle in this position, turn handwheel until holder is again at its low point of travel; then tighten nut. Return presser arm (G) to position; re-lock presser foot release bushing (P).

PRESSER FOOT PRESSURE

Sufficient pressure to feed work uniformly should be maintained. Should it be necessary to increase or decrease amount of pressure on presser foot, loosen lock nut (A, Fig. 2) and turn adjusting screw (B). Adjusting screw has a right hand thread; so tightening increases pressure, loosening decreases pressure. When pressure adjusting screw (B) has been properly set, tighten lock nut (A). With presser foot resting on throat plate, position locking nut (C) so that its under surface is approximately 1/32 inch to 1/16 inch from the top surface of adjusting screw (B). Set cap (D) against locking nut (C).

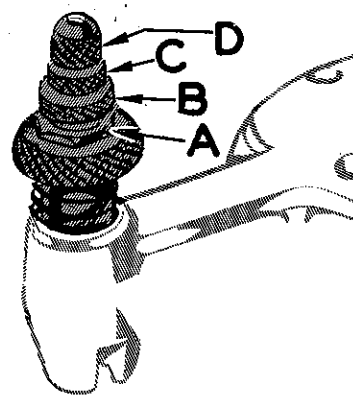

Fig. 2

FEED ECCENTRICS

Feed eccentric used in this machine has been selected to produce approximately 5 stitches per inch. It will be noted that the part number of main feed eccentric is No. 39540 B-5. Minor numbers of the part symbol indicate approximate number of stitches obtainable when using that eccentric. Unless otherwise specified, machine will be shipped with above eccentric.

FEED ECCENTRICS (Continued)

The following stitch number feed eccentrics are available under No. 39540 B: -4, -5, -6, -7, -8, -9, -10, -11, -12, -13, -14, -15, -16, -18, -20, -22, -24, -26, -28, -30, -32, -34, -36, -40. Only one eccentric is supplied with each machine. Additional eccentrics may be ordered separately. To order an eccentric, use number 39540 B with a minor number suffixed to indicate number of stitches desired. Example: "39540 B-5"

INSTRUCTIONS FOR THREADING STYLES 39500 J & K

THREAD STAND

After thread comes from cone on thread stand (R, Fig. 1), it is brought up through back thread eyelet, then down through front thread eyelet (S). Next it is threaded down through right hand hole of each pair of holes in tension thread guide wire (A). Then thread continues between tension discs (AD), through slot (AE), and on through thread guide (B).

THREADING

Only parts involved in threading are shown in threading diagram (Fig. 1). Parts are placed in their relative positions for clarity.

It will simplify threading this machine to follow recommended sequence of threading lower looper first, needle second.

Before beginning to thread, swing cloth plate open, turn handwheel in operating direction until needle (L) is at high position; release pressure on presser foot by turning presser foot release bushing (P) and swing presser arm (G) out of position.

Be sure threads, as they come from the tension thread guide, are between tension discs (AD) and in diagonal slots (AE) in tension posts (AC).

TO THREAD LOWER LOOPER

Double end of thread and lead it through both eyes of lower looper thread eyelet (C, Fig. 1) from right to left. NOTE: Thread must pass in front of looper thread pull-off (D). Lead thread behind fabric guard (E) and through both holes of frame looper thread guide (F). Turn handwheel in operating direction until heel of lower looper (H) is all the way to the left; then thread through both eyes from left to right. Right eye of lower looper can be threaded easily if tweezers are in left hand.

TO THREAD THE NEEDLE

Turn handwheel in operating direction until needle (L, Fig. 1) is at its highest position. Insert needle thread from back to front, through eye of needle thread eyelet (N), under neck of top cover casting, then right to left through hole in needle thread pull-off eyelet (M). Thread needle from front.

THREAD TENSION

The amount of tension on needle and looper threads is regulated by two knurled tension nuts (AA, Fig. 1). Tension on threads should be only enough to secure proper stitch formation.

↑ STYLES 39500 J & K ONLY ↓

STYLES 39500 J & K ONLY

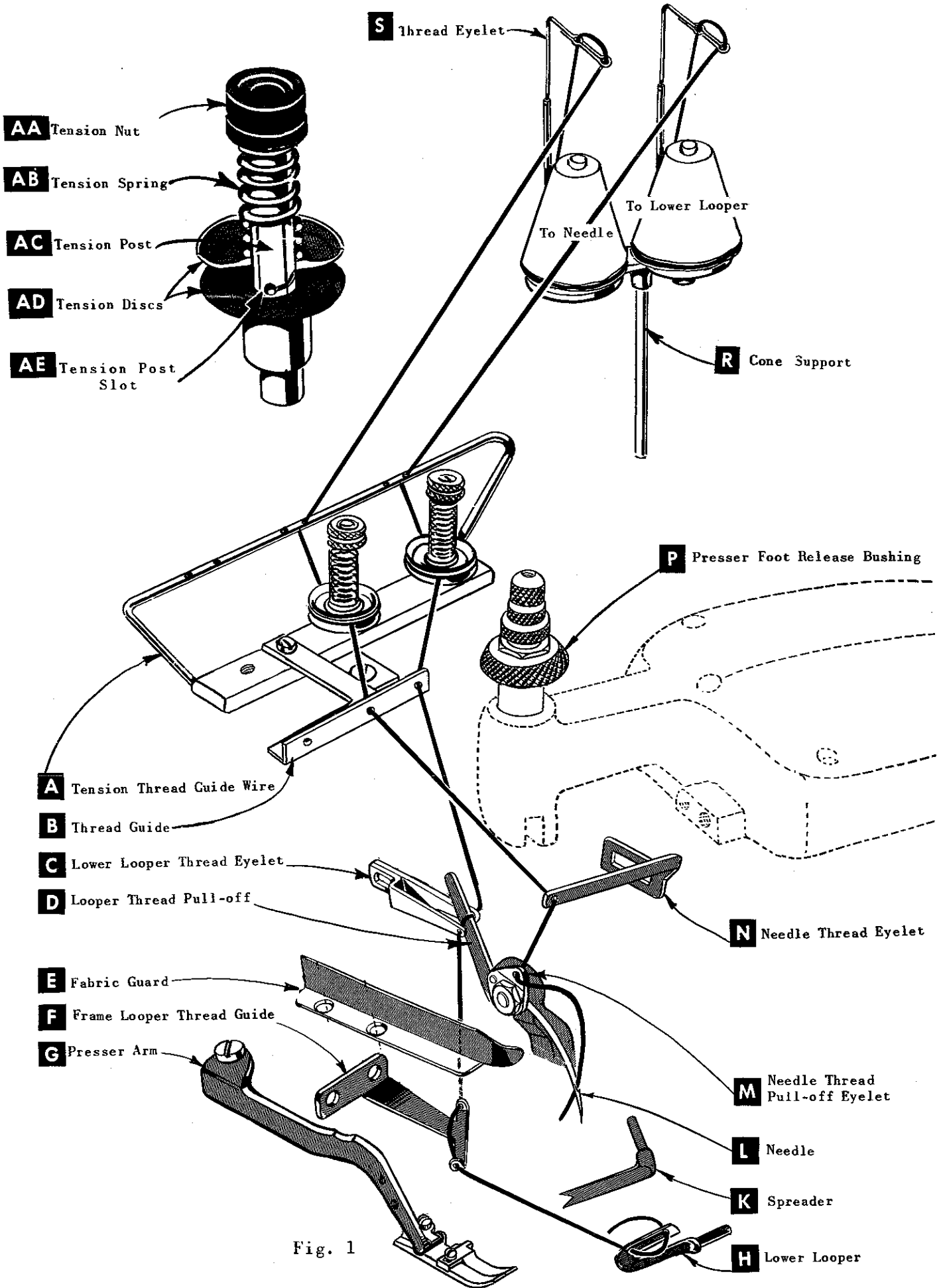

Fig. 1

AA Tension Nut

AB Tension Spring

AC Tension Post

AD Tension Discs

AE Tension Post Slot

W Thread Eyelet

To Upper Looper

To Needle

To Lower Looper

V Cone Support

U Presser Foot Release Bushing

T Looper Thread Pull-off

A Tension Thread Guide Wire

B Thread Guide

C Upper Looper Thread Eyelet

D Auxiliary Looper Thread Eyelet

E Lower Looper Thread Eyelet

F Fabric Guard

G Frame Looper Thread Guide

H Presser Arm

R Needle Thread Eyelet

P Needle Thread Pull-off Fyelet

N Upper Looper Thread Tube Assembly

M Needle

L Upper Looper

K Lower Looper

Fig. 1A

INSTRUCTIONS FOR THREADING STYLES 39500 L & M

THREAD STAND

After thread comes from cone on thread stand (V, Fig. 1A), it is brought up through back thread eyelet, then down through front thread eyelet (W). Next it is threaded down through right hand hole of each pair of holes in tension thread guide wire (A), and up through left hand hole. Then thread continues between tension discs (AD), through slot (AE), and on through thread guide (B).

THREADING

Only parts involved in threading are shown in threading diagram (Fig. 1A). Parts are placed in their relative positions for clarity.

It will simplify threading this machine to follow recommended sequence of threading lower looper first, upper looper second, and needle third.

Before beginning to thread: swing cloth plate open; turn handwheel in operating direction until needle (M) is at high position; release pressure on presser foot by turning presser foot release bushing (U); swing presser arm (H) out of position.

Be sure threads, as they come from the tension thread guide, are between tension discs (AD) and in diagonal slots (AE) in tension posts (AC).

TO THREAD LOWER LOOPER

Double end of thread and lead it through both eyes of lower looper thread eyelet (E, Fig. 1A) from right to left. Note thread must pass in front of looper thread pull-off (T). Lead thread behind fabric guard (F) and through both holes of frame looper thread guide (G). Turn handwheel in operating direction until heel of lower looper (K) is all the way to the left; then thread through both eyes from left to right. Right eye of lower looper can be threaded easily if tweezers are in left hand.

TO THREAD UPPER LOOPER

Turn handwheel so that needle (M, Fig. 1A) is again at high position. Lead thread through auxiliary looper thread eyelet (D) from back to front, and then through both eyes of upper looper thread eyelet (C) from left to right. Note that thread must pass in front of looper thread pull-off (T). After pulling up upper looper thread tube assembly (N), lead thread under neck of top cover casting and down through thread tube assembly. Pull thread out bottom of tube; push tube down. Turn handwheel until point of upper looper (L) is all the way to the left; then insert thread through eye from front to back.

CAUTION: Be sure upper looper thread is under lower looper thread when passing from tube assembly to upper looper eye.

TO THREAD THE NEEDLE

Turn handwheel in operating direction until needle (M, Fig. 1A) is at its highest position. Insert needle thread from back to front, through eye of needle thread eyelet (R), under neck of top cover casting; then right to left through hole in needle thread pull-off eyelet (P). Thread needle from front.

THREAD TENSION

The amount of tension on needle and looper threads is regulated by three knurled tension nuts (AA, Fig. 1A). Tension on threads should be only enough to secure proper stitch formation.

STYLES 39500 L & M ONLY

ASSEMBLING AND ADJUSTING SEWING PARTS

Before assembling sewing parts: remove cloth plate, fabric guard, chip guard, upper knife assembly, lower knife holder assembly; then follow this suggested sequence.

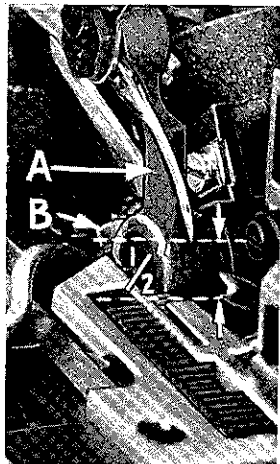

Fig. 3

SETTING THE NEEDLE

With throat plate in position, needle should center in the front end of needle slot. When needle is at high position, needle point should be set 1/2 inch above throat plate (Fig. 3). Move needle driving arm (A, Fig. 3) by loosening clamp screw (B). Remove throat plate.

At this point, insert lower looper (A, Fig. 5) into bar (B). With lower looper at left end of its stroke, set looper point 1/8 inch from center of needle (Fig. 5), using looper gauge No. 21225-1/8. Do not have lower looper deflecting needle. Tighten nut (C).

Now assemble main (front) feed dog (E, Fig. 4)

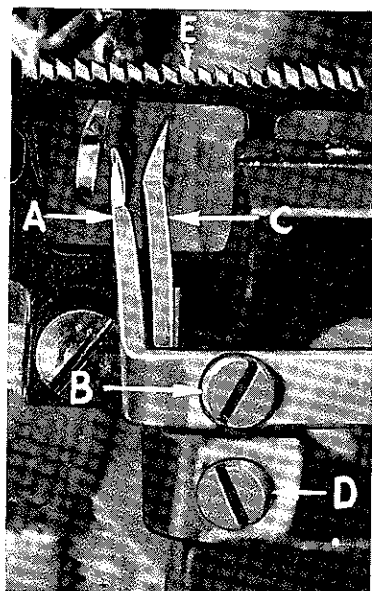

Fig. 4

SETTING THE REAR NEEDLE GUARD

Set rear needle guard (A, Fig. 4) as high as possible, without interfering with either lower looper or movement of lower knife holder; but still in position to deflect needle forward .002 - .004 inch. Screw (B) is used to set rear needle guard.

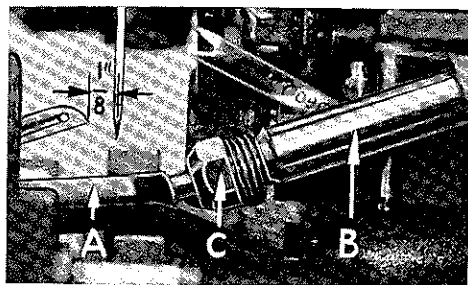

Fig. 5

SETTING THE LOWER LOOPER

Now finish lower looper adjustment. As lower looper moves to the right, its point should be set into the needle scarf (A, Fig. 6) until the needle springs forward from rear guard surface another .002 - .004 inch.

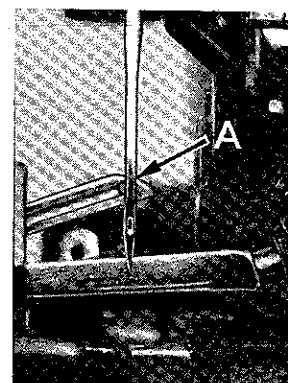

Fig. 6

SETTING THE FRONT NEEDLE GUARD

Assemble front needle guard (C, Fig. 4). When lower looper is springing needle off back guard, set front needle guard as close as possible to needle without touching. Screw (D) is used to adjust and set front needle guard. After this setting, make sure there is no interference between needle guards and main feed dog.

SETTING THE SPREADER - STYLES 39500 J AND K ONLY

Insert spreader (A, Fig. 7) in its holder. Screw (B, Fig. 7) holds spreader in its holder, and permits spreader to be pushed in or out or turned around its shank. Screw (C, Fig. 7) on collar holds spreader holder in the shaft, and allows holder to be rotated or adjusted laterally.

Preliminary Setting: When the spreader is at the right end of its stroke, spreader holder should be set to position spreader shank back of vertical (Fig. 7). The top end of spreader shank should extend about $\frac{3}{64}$ inch above holder (Fig. 7).

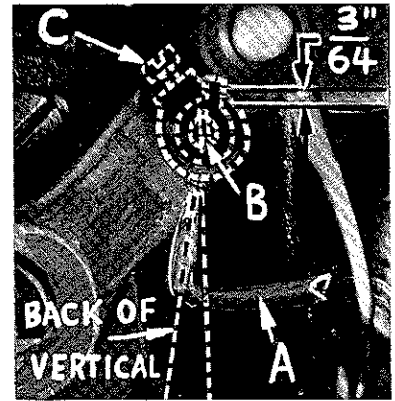

Fig. 7

As spreader moves from right to left, the Vee notch of the spreader should pass just behind the eye of the lower looper, with approximately .002 inch clearance between spreader and lower looper (Fig. 8).

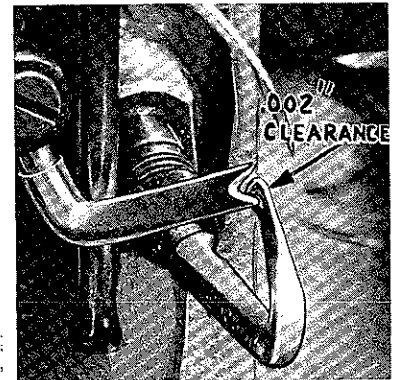

Fig. 8

Continue turning the handwheel until spreader is at left end of its travel. At this position, the lower point of the spreader should extend about $\frac{1}{8}$ inch to the left of the centerline of the needle and should be approximately $\frac{3}{8}$ inch above the top of the throat plate (Fig. 9).

This setting will give a good close relationship to the needle and spreader. If needle rubs the back of the spreader, refer to the paragraph that follows.

The spreader holder should be brought out far enough to satisfy the above dimensions and so as to avoid hitting the fabric guard with the spreader holding screw.

Now check setting between spreader and needle. If needle rubs the back of spreader, pull spreader out of its holder slightly and rotate spreader holder forward a short distance. These same adjustments, in opposite movement, will reduce the clearance between spreader and needle. Reset to lower looper (Fig. 8).

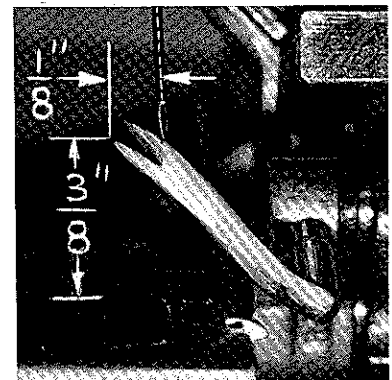

Fig. 9

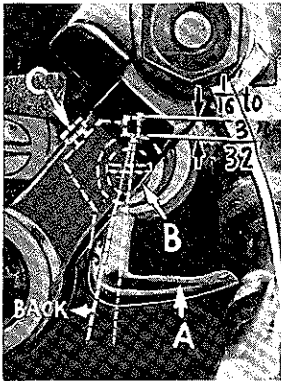

Fig. 7A

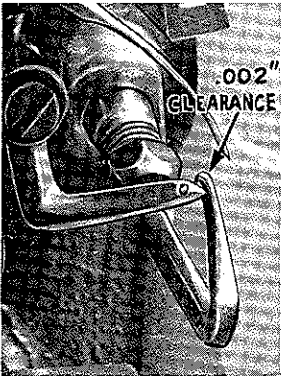

Fig. 8A

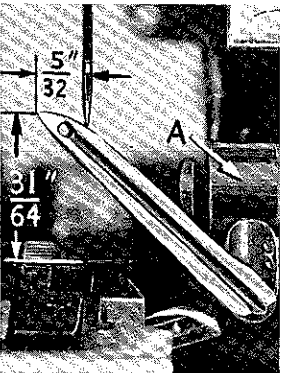

Fig. 9A

SETTING THE UPPER LOOPER - STYLES 39500 L & M ONLY

Insert upper looper (A, Fig. 7A) in its holder. Screw (B, Fig. 7A) holds upper looper in its holder, and permits it to be pushed in or out or turned around its shank. Insert upper looper holder into upper looper shaft, if it is not already in place. Screw (C, Fig. 7A) on clamp holds upper looper holder in shaft. Locate upper looper in its holder so that shank extends $1/16$ to $3/32$ inch beyond holder (Fig. 7A).

When upper looper is at right end of its stroke, upper looper holder should be set to position upper looper shank back of vertical (Fig. 7A), but be sure there is clearance between heel of looper and casting. Now, by adjusting looper holder in or out of upper looper shaft and by turning looper around its shank, set upper looper point to cross lower looper to the left of lower looper eye with $.002$ to $.004$ clearance (Fig. 8A).

Next turn handwheel until upper looper is at left end of its travel; check the $5/32$ inch dimension of upper looper point from center line of needle (Fig. 9A). If the $5/32$ inch dimension is too small: pull upper looper holder out of upper looper shaft to correct the condition. Turn upper looper holder forward (counterclockwise looking from left end of machine) so that upper looper point crosses lower looper, without interference, as close as possible to the left of lower looper eye. It may be necessary to rotate upper looper around its shank slightly to maintain conditions shown (Fig. 8A).

If the $5/32$ inch dimension is too large: push upper looper holder into upper looper shaft to correct the condition. Turn upper looper holder backward, if necessary, so that upper looper point crosses lower looper, without interference, as close as possible to the left of lower looper eye. It may be necessary to rotate upper looper around its shank slightly to maintain conditions shown (Fig. 8A).

If needle now rubs the back of upper looper, pull upper looper out of its holder to reduce the $1/16$ to $3/32$ inch dimension (Fig. 7A); reset upper looper as previously described.

← STYLES 39500 L & M ONLY →

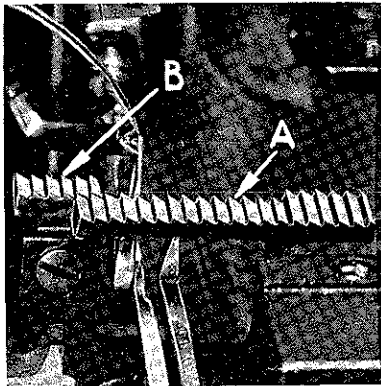

Fig. 10

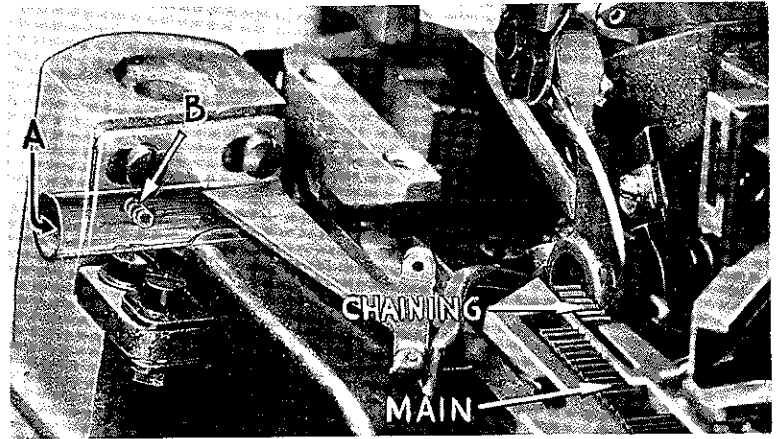

Fig. 11

SETTING THE FEED DOGS

Assemble chaining feed dog (B, Fig. 10) to main feed dog (A).

Feed Dogs should be leveled with throat plate surface by rotating feed tilting adjusting pin (A, Fig. 11). This pin raises or lowers the back end of feed bar. Feed dogs should be set level at the time teeth first appear above throat plate. Screw (B) locks feed tilting adjusting pin in place. Now set feed dogs at highest point of travel: main feed dog teeth set $3/64$ inch above throat plate; and chaining feed dog teeth set about flush with surface of throat plate.

SETTING THE LOWER KNIFE

Replace lower knife holder assembly. Lower knife (A, Fig. 12) should be set with cutting edge flush with throat plate surface. Adjustments are made with hexagonal head screw which holds lower knife. Lower knife is spring pressed against upper knife, so no lateral adjustment is necessary when width of trim is changed.

NOTE: On Style 39500 K & M, lower knife is set up to, but not touching, underside of throat plate.

Lower knife may be secured in any position by tightening screw (B) and locking nut (C) against support bracket. Because screw (B) also serves as latch pin for the cloth plate latch spring, it should always be locked with nut (C) even when screw is not tightened against lower knife holder.

SETTING THE UPPER KNIFE

Replace upper knife assembly. Clamp upper knife (D, Fig. 12) in position, setting screw (E) to hold clamp (F) in its most clockwise position against upper knife. At bottom of its stroke, front cutting edge of upper knife should extend not less than $1/64$ inch below cutting edge of lower knife.

After upper knife has been set for proper width of trim, screw (G) should be tightened to lock upper knife holding block (H) in place. This will simplify resetting when upper knife is replaced.

NOTE: On Style 39500 K & M, upper knife is removed from machine.

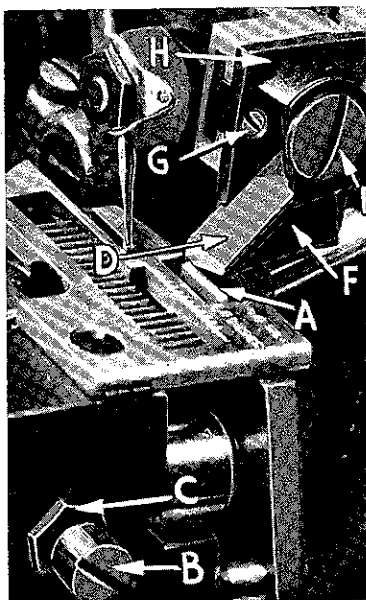

Fig. 12

SETTING THE STITCH LENGTH

Stitch length is determined by feed eccentric used. Note that part number of feed eccentric in machine is No. 39540 B-5.

In assembling feed eccentric (A, Fig. 13) be sure hub side of eccentric is placed on the right. Hub side of feed eccentric spacer and oil slinger (B) should be to the left. Be careful not to damage shaft or key. Tighten nut (C) securely. Be sure wool yarn in oil tube (D) touches feed eccentric spacer and oil slinger (B).

To change feed eccentric, remove nut (C) and oil slinger (B) from end of shaft. Turn handwheel in operating direction until key slot in eccentric is toward front. Using hooked eccentric extractor (E), supplied with machine, reach behind eccentric as shown, and withdraw eccentric. It may be necessary to rock handwheel slightly during extraction. Use care in passing under oil tube (D) to avoid loosening from its position.

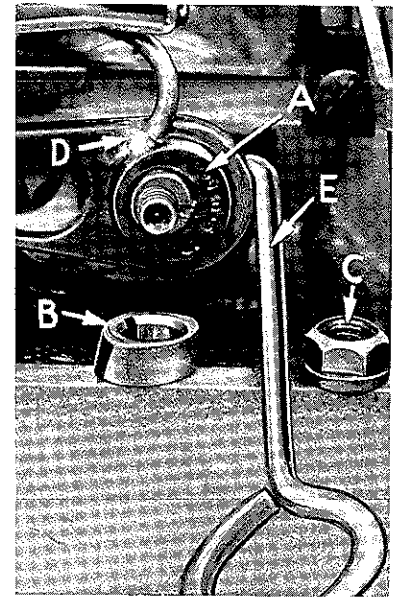

Fig. 13

SETTING THE PRESSER FOOT

Assemble presser foot to presser arm. With needle in high position, swing presser arm into sewing position and lock in place. If necessary, presser foot can be realigned with throat plate slots by shifting foot lifter lever shaft.

Foot lifter lever arm (A, Fig. 14) and collar (B) secure the shaft. Be sure presser arm does not bind and rise when presser foot release bushing is unlocked. To center presser foot and stitch tongue with respect to throat plate needle hole, loosen presser foot hinge screw.

Adjust lifter lever stop screw (C) so that presser foot can be raised no higher than upper looper will permit; then lock nut (D). There should be from 1/16 to 1/8 inch free motion of foot lifter lever before presser foot begins to rise. This adjustment should be made with screw (E) and locked with nut (F).

Finally, reassemble chip guard, fabric guard and cloth plate.

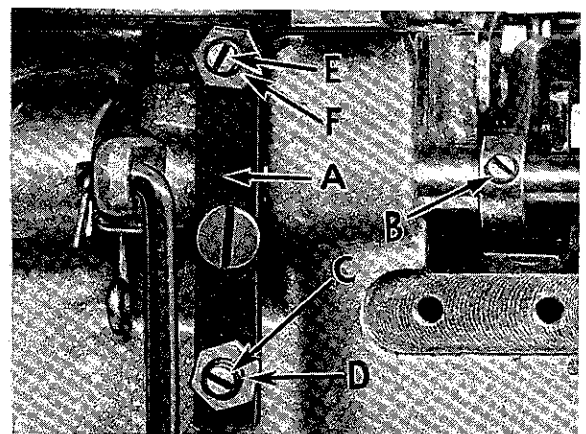

Fig. 14

STARTING TO OPERATE STYLES 39500 J & K

Be sure machine is threaded according to threading diagram (Fig. 1, page 8).

With thread tensions light, set looper thread eyelet (C) about horizontal and in the middle of its front to back location.

Operate machine slowly, without presser foot in place, to make sure chain forms and moves off tongue freely.

Swing presser foot into position; insert material; sew slowly.

NEEDLE THREAD CONTROL

While sewing on material, check needle thread control as follows: About 75% of needle thread required for the stitch should be drawn on needle downstroke. To increase thread drawn on downstroke, position needle thread eyelet (N) farther to the rear.

LOWER LOOPER THREAD CONTROL

With material under presser foot, set lower looper thread eyelet (C, Fig. 1) back and down far enough so thread is a little slack when spreader reaches its extreme left position. Looper thread eyelet (C) should be about horizontal.

Frame looper thread guide (F) should be set with its left hand eyelet approximately 1/8 inch right of looper (H) heel eyelet at the time lower looper is at extreme left end of its travel.

THREAD TENSIONS

Before proceeding, balance both tensions to give a normal appearing stitch. Moderate change in these tensions will not markedly effect the purl.

SPECIAL ADJUSTMENTS

SKIPPING: For occasional skipping, check and/or adjust as outlined below:

1. Recheck lower looper - needle setting. See "Setting the Needle", page 11.
2. Recheck spreader - lower looper crossing. See "Setting the Spreader", page 12.
3. Check clearance between needle and spreader. See that spreader moves far enough left past needle.

Settings 1 and 2 should be made quite carefully. If it can be determined by appearance that skip is definitely not a needle loop skip, reposition looper thread eyelet (C) by lowering it slightly and bringing eyelet holes in close to bend in looper thread pull-off (D). After this change, increase looper thread tension as much as possible without distorting stitch.

CAUTION: Looper thread must, as before, be slightly slack as spreader reaches its extreme left position, or stitch will appear tight on top side.

STARTING TO OPERATE STYLES 39500 L & M

Be sure machine is threaded according to threading diagram (Fig. 1A, p. 9).

With thread tensions light, set upper and lower looper thread eyelets (C & E) about horizontal and in the middle of their front to back locations.

Operate machine slowly, without presser foot in place, to make sure that chain forms and moves off the tongue freely.

Swing presser foot into position, insert material, and sew slowly.

NEEDLE THREAD CONTROL

While sewing on material, check needle thread control as follows: About 60% of needle thread required for the stitch should be drawn on needle downstroke.

To increase thread drawn on downstroke, position needle thread eyelet (R, Fig. 1A) farther to the rear.

LOWER LOOPER THREAD CONTROL

Set lower looper thread eyelet (E, Fig. 1A) about horizontal and all the way forward in its slot.

Frame looper thread guide (G) should be set with its left hand eyelet approximately 1/8 inch right of lower looper heel eyelet, when lower looper is at the left end of its stroke.

UPPER LOOPER THREAD CONTROL

With material under presser foot, set upper looper thread eyelet (C, Fig. 1A) to rest on top of lower looper thread eyelet (E), and back far enough so upper looper thread is a little slack when upper looper reaches the left end of its stroke.

POSITIONING THE SQUARE EDGE

Position of lower looper thread at the edge is located by balancing needle and upper looper thread tensions.

To reduce amount of lower looper thread in the stitch, or close the edge more, increase lower looper thread tension.

← STYLES 39500 L & M ONLY →

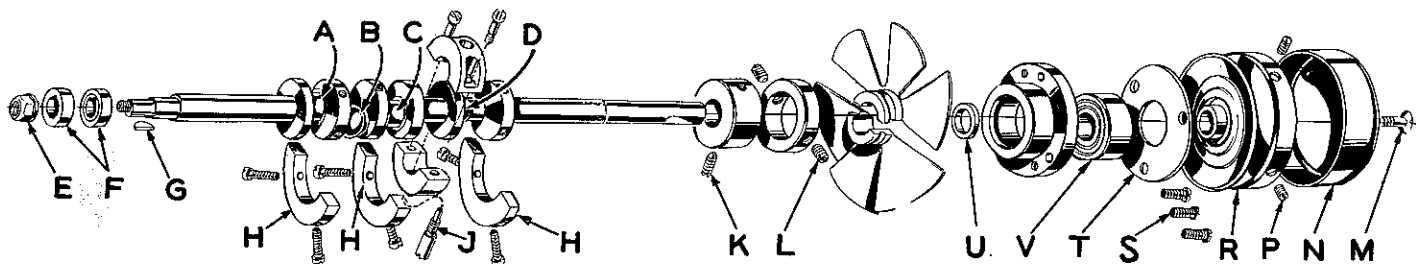

Fig. 17

TO REMOVE CRANKSHAFT

Crankshaft can be withdrawn easier if these steps are followed:

1. Drain oil by removing plug screw located on back of machine near bottom edge of base.
2. Remove top and bottom covers of machine.
3. Remove feed eccentric nut (E, Fig. 17) and, with the aid of the eccentric extractor, slip off the eccentrics (F).
4. Remove key (G).
5. Remove three counterweights (H). Identify these counterweights so that they will be re-assembled in the proper places.
6. Remove screw (J) which holds crankshaft split bearing. This screw is reached through bottom of bed casting.
7. Remove caps of bearings on crankshaft at points A, B, and D. When re-assembling bearing caps make sure they are in their original position. Trade marks are stamped on both halves of the caps and both trade marks should be on the same side of the bearings. Also, screws should be re-assembled in the same holes from which they were removed.
8. Loosen clamp nut (A, Fig. 18) which holds upper knife driving arm (E). Access to clamp nut is through top cover. Draw driving arm to the left until upper knife driving lever (C) and connecting rod (D) drop, allowing removal of bearing cap (E). This is at bearing point (C, Fig. 17) on crankshaft. Observe same precautions when re-assembling cap as described in 7 above.
9. Remove screw (K, Fig. 17) which holds inner right crankshaft bearing. This screw is reached through bottom of bed casting.
10. Loosen two screws (L) in fan collar; remove both halves of cooling fan.
11. Remove screw (M); take off pulley cap (N).
12. Loosen two screws (P); remove pulley (R).
13. Remove three screws (S); take off bearing retaining plate (T).
14. Crankshaft may now be removed.
15. If necessary to replace ball bearing (V), it should be pressed off shaft on an arbor press. In replacing bearing it must be pressed on carefully until it seats against ground thrust washer (U).
16. Carefully observing reverse of the foregoing operations should simplify re-assembly of crankshaft. Checking exploded view drawings for location of various parts and constant testing for binds during re-assembly will also prove helpful.
17. Before re-assembling, thoroughly clean and dry top and bottom covers and gaskets. Before re-assembling bottom cover make sure that spring pressed oil wick which lubricates left crankshaft bearing is inserted in hole in casting and that it contacts shaft. The wick stands vertically on its spring against bottom cover. Coat oil drain plug with a sealing compound before re-assembling to prevent oil leakage. No. 1 Crane Lead Seal is recommended.

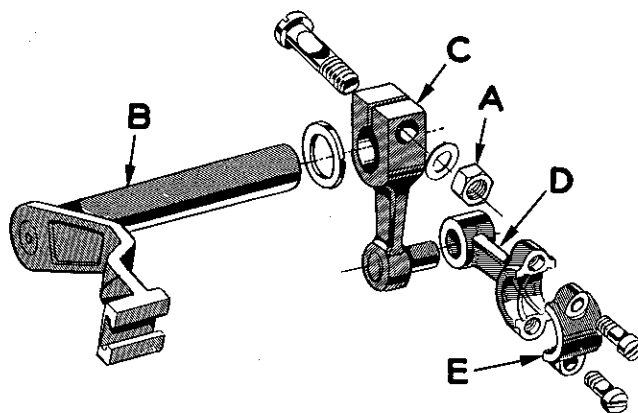

Fig. 18

ORDERING REPAIR PARTS

ILLUSTRATIONS

This catalog has been arranged to simplify ordering repair parts. Exploded views of various sections of the mechanism are shown so that the parts may be seen in their actual position in the machine. On the page opposite the illustration will be found a listing of the parts with their part number, description and the number of pieces required in the particular view being shown.

Numbers in the first column are reference numbers only, and merely indicate the position of that part in the illustration. Reference numbers should never be used in ordering parts. Always use the part number listed in the second column.

Component parts of sub-assemblies which can be furnished for repairs are indicated by indenting their descriptions under the description of the main sub-assembly. Example:

41	29126 DF	Lower Looper Drive Lever Connecting Rod Assembly-----	1
42	22729 D	Screw, for No. 39544 N -----	2
42A	22729 E	Screw, for No. 39544 N -----	2
43	97	Screw, for No. 39544 S -----	2
44	39544 S	Ball Joint Guide Fork -----	1
45	39544 U	Lower Looper Bar Driving Lever-----	1

It will be noted in the above example that the eccentric, ball stud, and bearing are not listed. The reason is that replacement of these parts individually is not recommended, so complete sub-assembly should be ordered.

Where parts for Styles 39500 J, 39500 K, 39500 L and 39500 M are not the same, the difference will be shown in the illustrations or mentioned in the descriptions. When a part is used in all machines covered by this catalog no machine style will be mentioned.

At the back of the book will be found a numerical index of all the parts shown in this book. This will facilitate locating the illustration and description when only the part number is known.

IDENTIFYING PARTS

Where the construction permits, each part is stamped with its part number. On some of the smaller parts, and on those where construction does not permit, an identification letter is stamped in to distinguish the part from similar ones.

PART NUMBERS REPRESENT THE SAME PART, REGARDLESS OF CATALOG IN WHICH THEY APPEAR.

USE GENUINE NEEDLES AND REPAIR PARTS

Success in the operation of these machines can be secured only with genuine Union Special Needles and Repair Parts as furnished by the Union Special Machine Company, its subsidiaries and authorized distributors. They are designed according to the most scientific principles, and are made with utmost precision. Maximum efficiency and durability are assured.

Genuine needles are packaged with labels marked *Union Special*. Genuine repair parts are stamped with the Union Special trademark. Each trademark is your guarantee of the highest quality in materials and workmanship.

TERMS

Prices are net cash and subject to change without notice. All shipments are forwarded f. o. b. shipping point. Parcel post shipments are insured unless otherwise directed. A charge is made to cover postage and insurance.

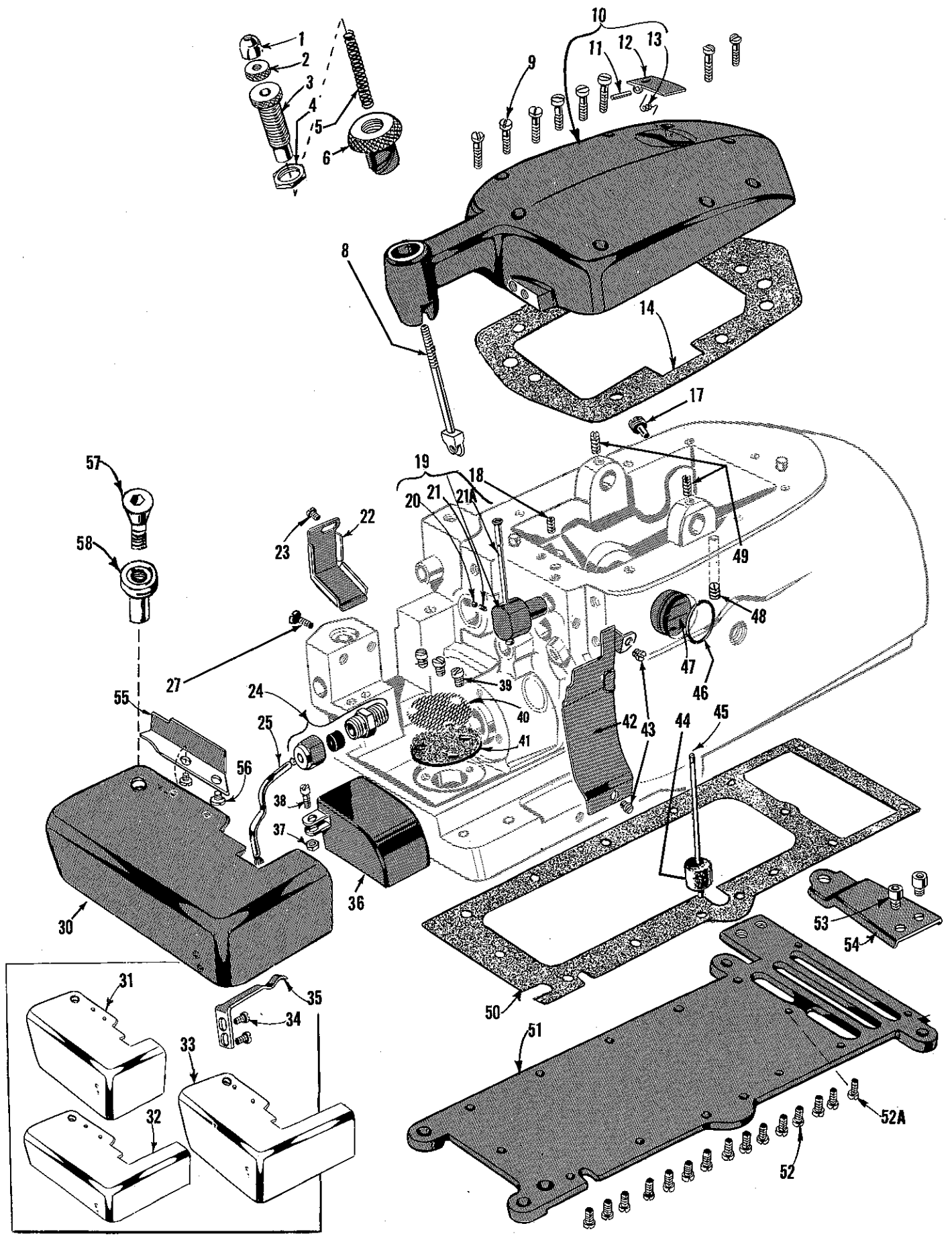

MAIN FRAME, MISCELLANEOUS COVERS, PLATES

<u>Ref. No.</u>	<u>Part No.</u>	<u>Description</u>	<u>Amt. Req.</u>
1	39557 B	Presser Spring Plunger Cap Nut -----	1
2	39557 E	Presser Spring Plunger Locking Nut-----	1
3	39557 C	Presser Spring Plunger Adjusting Screw -----	1
4	39557 F	Lock Nut - Adjusting Screw-----	1
5	39557	Presser Spring-----	1
6	39556 A	Presser Foot Release Bushing -----	1
8	39557 A	Presser Spring Plunger -----	1
9	22541	Screw - Top Cover -----	8
10	39582 S	Top Cover -----	1
11	51-103 Blk.	Hinge Pin-----	1
12	39582 L	Oil Filler Cover-----	1
13	39582 V	Spring-----	1
14	39582 AA	Top Cover Gasket -----	1
17	22571 E	Oil Drain Plug Screw -----	1
18	22565	Screw - Upper Looper Thread Tube Assembly -----	1
19	29477 GW	Upper Looper Thread Tube Assembly-----	1
20	22743	Screw - Tube Tension Spring -----	1
21	39568 J	Looper Thread Tube Tension Spring -----	1
21A	39568 G	Thread Tube -----	1
22	39534 R	Feed Bar Oil Shield-----	1
23	90	Screw - Feed Bar Oil Shield -----	1
24	660-234	Oil Tube Coupling -----	1
25	39594 A	Feed Eccentric Spacer Oil Tube-----	1
27	22569	Screw - Cloth Plate Stud -----	1
30	39501 A	Cloth Plate, semi-submerged installation -----	1
31	39501	Cloth Plate, nonsubmerged installation -----	1
32	39501 C	Cloth Plate, semi-submerged installation -----	1
33	39501 B	Cloth Plate, nonsubmerged installation -----	1
34	90	Screw - Latch Spring -----	2
35	39532 A	Cloth Plate Latch Spring -----	1
36	39582 K	Feed Mechanism Cover-----	1
37	41071 G	Nut - Feed Mechanism Cover -----	1
38	86 X	Screw - Feed Mechanism Cover-----	1
39	22569 A	Screw - Oil Screen and Strainer-----	3
40	39594 G	Oil Filter Screen -----	1
41	39594 H	Oil Strainer-----	1
42	39578 BB	Chip Guard -----	1
43	22569 D	Screw - Chip Guard-----	2
44	39593 C	Oil Gauge Float -----	1
45	39593 D	Oil Gauge Indicator -----	1
46	660-243	Oil Gauge Seal Ring-----	1
47	39593 E	Oil Sight Gauge-----	1
48	22894 AD	Screw - Lower Looper Bar Lever Shaft -----	2
49	22565	Screw - Upper Looper Drive Lever Shaft-----	2
50	39582 Y	Bottom Cover Gasket-----	1
51	39582 X	Bottom Cover -----	1
52	22569 C	Screw - Bottom Cover -----	14
52A	22586 R	Screw - Bottom Cover -----	1
53	22653 D-4	Screw - Bottom Cover Extension -----	2
54	39582 F	Bottom Cover Extension-----	1
55	39578 F	Cloth Plate Fabric Guard-----	1
56	138	Screw - Fabric Guard-----	2
57	22657 D-12	Screw - Cloth Plate-----	1
58	39501 K	Stud - Cloth Plate -----	1

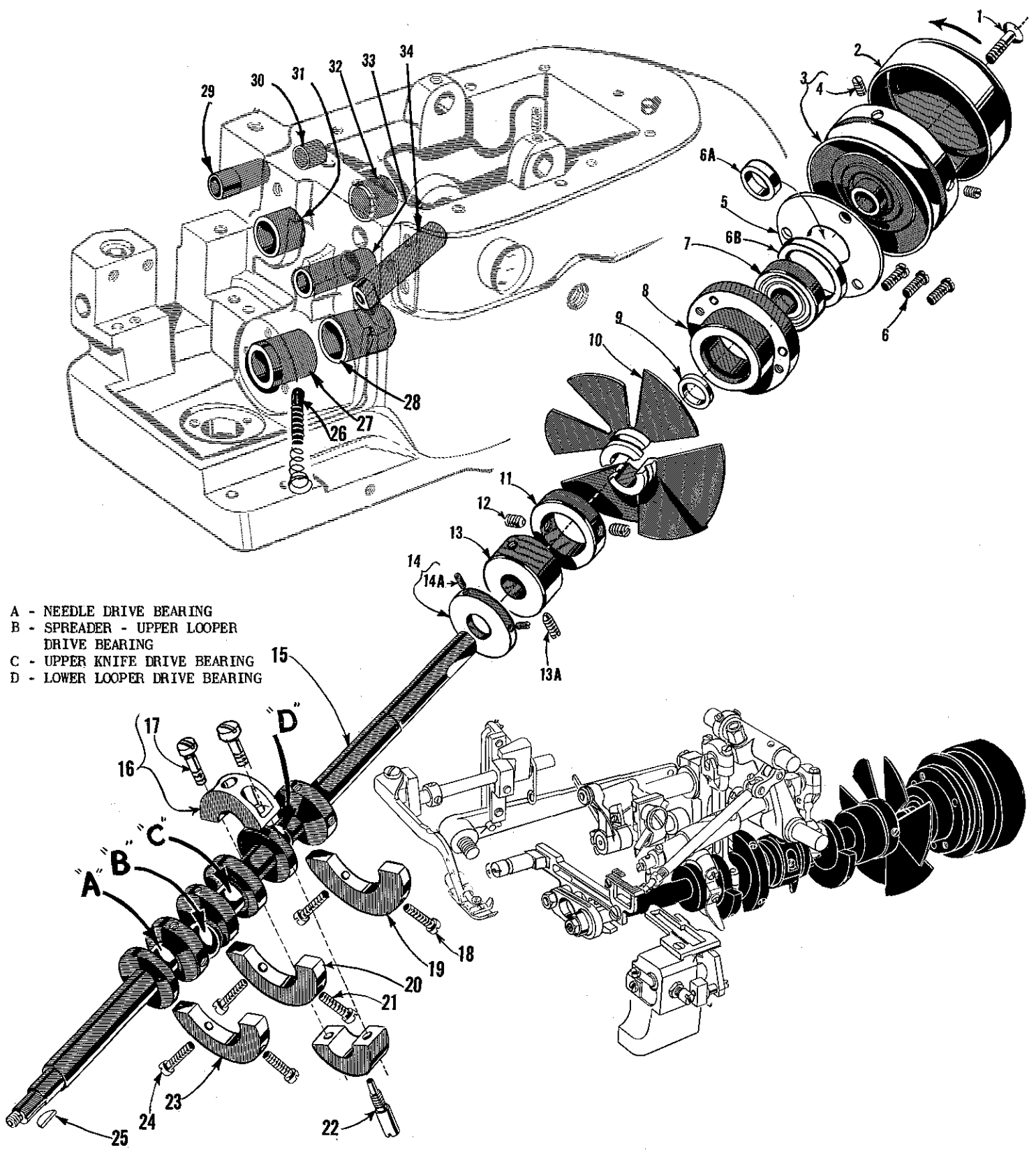

- A - NEEDLE DRIVE BEARING
- B - SPREADER - UPPER LOOPER DRIVE BEARING
- C - UPPER KNIFE DRIVE BEARING
- D - LOWER LOOPER DRIVE BEARING

CRANKSHAFT MECHANISM AND BUSHINGS

<u>Ref. No.</u>	<u>Part No.</u>	<u>Description</u>	<u>Amt. Req.</u>
1	22769 A	Screw, for pulley cap -----	1
2	39521 A	Pulley Cap -----	1
3	39521	Pulley -----	1
4	95	Screw -----	2
5	39590 H	Crankshaft Ball Bearing Retaining Plate -----	1
6	22569	Screw -----	3
6A	39590 S	Spacer Collar -----	1
6B	39590 R	Ball Bearing Stop Collar -----	1
7	660-268	Crankshaft Ball Bearing -----	1
8	39590 G	Crankshaft Ball Bearing Housing -----	1
9	39590 J	Thrust Washer -----	1
10	39591 L	Crank Chamber Cooling Fan -----	1
11	39591 H	Crank Chamber Cooling Fan Collar -----	1
12	22894 D	Screw -----	2
‡13		Crankshaft Bearing, inner right -----	1
13A	22565 F	Screw -----	1
14	39590 P	Oil Slinger Collar -----	1
14A	77 Q	Screw -----	2
*15		Crankshaft -----	1
16	39590 D	Crankshaft Split Bearing -----	1
17	97 A	Screw, for split bearing -----	2
18	22747 B	Screw, for crankshaft counterweight -----	2
19	39591 B	Crankshaft Counterweight, right -----	1
20	39591 A	Crankshaft Counterweight, middle -----	1
21	22747 B	Screw, for crankshaft counterweight -----	2
22	39590 N	Stud, for crankshaft split bearing -----	1
23	39691	Crankshaft Counterweight, left -----	1
24	22747 B	Screw, for crankshaft counterweight -----	2
25	39541	Feed Driving Eccentric Key -----	1
26	666-94	Oil Wick and Spring -----	1
27	39590	Crankshaft Bushing, left -----	1
28	39590 C	Crankshaft Bushing, inner left -----	1
29	39555 E	Foot Lifter Shaft Bushing, left -----	1
30	39142 G	Foot Lifter Shaft Bushing, right -----	1
31	39573 K	Upper Knife Driving Arm Bushing, left -----	1
32	39573 AA	Upper Knife Driving Arm Bushing, right -----	1
33	39552 B	Needle Driving Arm Crank Bushing -----	1
34	39544 L	Lower Looper Bar Bushing -----	1

‡ Discontinued - For customer repair, order Kit of Parts No. 29480 LB.

* Discontinued - For customer repair, order Crankshaft and Needle Driving Crank Sub-Assembly No. 29477 JA.

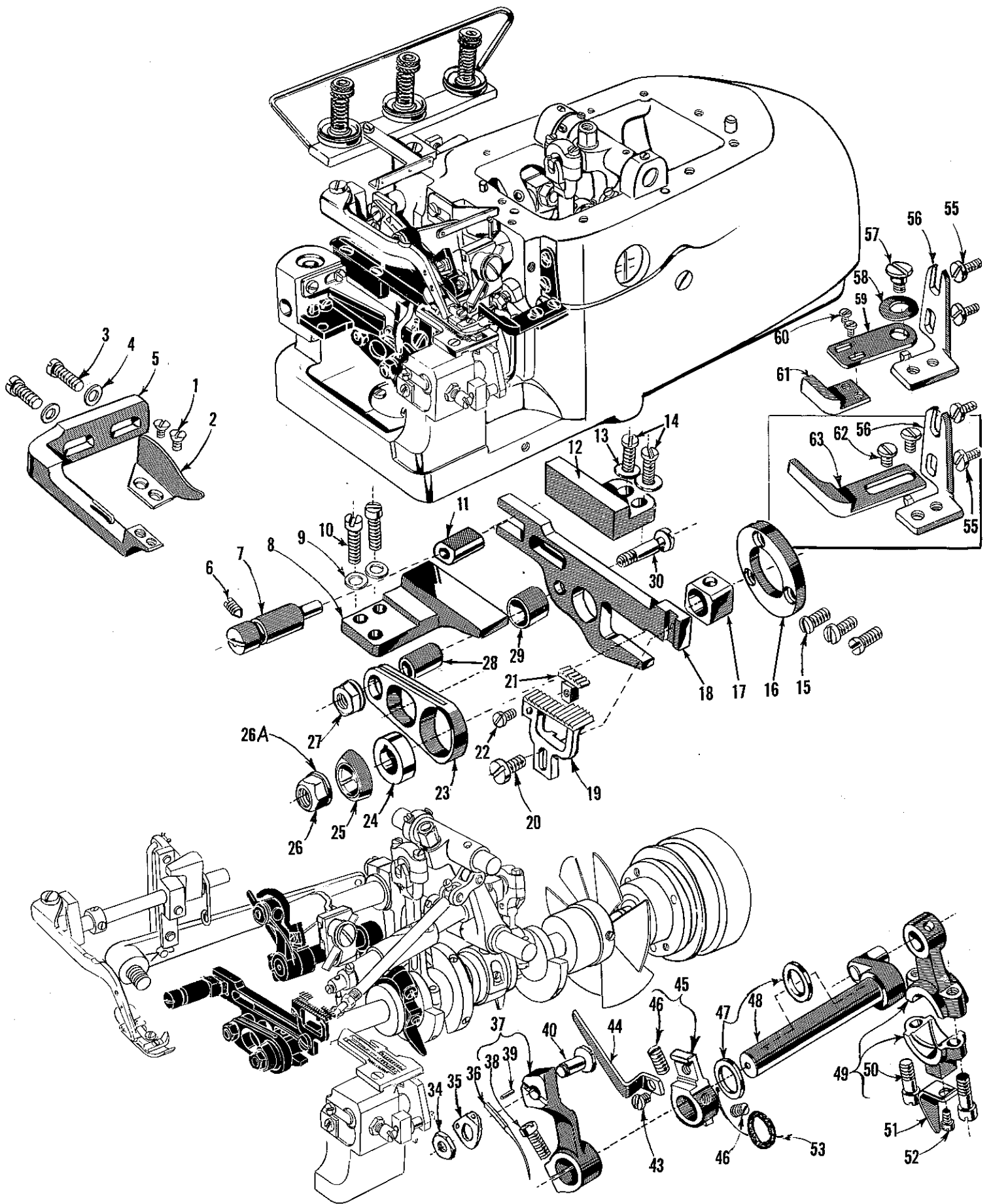

NEEDLE DRIVE AND FEED MECHANISM

<u>Ref. No.</u>	<u>Part No.</u>	<u>Description</u>	<u>Amt. Req.</u>
1	87	Screw - Fabric Guard -----	2
2	39578 M	Fabric Guard, for Style 39500 J -----	1
-	39578 R	Fabric Gaurd, for Styles 39500 K, L, M -----	1
3	22569 B	Screw - Mounting Bracket -----	2
4	8372 A	Mounting Bracket Washer-----	2
5	39578 P	Fabric Guard Mounting Bracket -----	1
6	22565 F	Screw - Adjusting Pin -----	1
7	39535 C	Feed Tilting Adjusting Pin -----	1
8	39535 F	Main Feed Bar Guide, left -----	1
9	53634 C	Feed Bar Guide Washer -----	2
10	22569	Screw - Feed Bar Guide, left -----	2
11	39535 J	Feed Bar Guide Block -----	1
12	39535 D	Feed Bar Guide, right-----	1
13	53634 C	Feed Bar Guide Washer -----	2
14	22569 B	Screw - Feed Bar Guide, right -----	2
15	22569 G	Screw - Thrust Washer-----	3
16	39534 H	Feed Bar Thrust Washer -----	1
17	39538	Feed Lift Block-----	1
18	39534 G	Main Feed Bar -----	1
19	39505 J	Main Feed Dog -----	1
20	22528	Screw - Main Feed Dog-----	1
21	39505 K	Chaining Feed Dog -----	1
22	22768 B	Screw - Chaining Feed Dog -----	1
23	39536 A	Main Feed Bar Driving Connection-----	1
24	39540 B-5	Main Feed Driving Eccentric, .124 inch throw -----	1
25	39540 J	Feed Eccentric Spacer and Oil Slinger -----	1
26	18	Nut - Crankshaft-----	1
26A	20	Washer -----	1
27	39536 E	Nut - Feed Bar Driving Stud -----	1
28	39536 C	Feed Bar Driving Connection Bushing -----	1
29	39536 D	Feed Bar Spacer-----	1
30	39536 B	Feed Bar Driving Stud-----	1
34	14077	Nut - Needle Clamp Stud-----	1
35	39563 Z	Needle Thread Pull-off Eyelet-----	1
36		Needle-----	1
37	39552	Needle Driving Arm-----	1
38	22596 E	Screw - Needle Driving Arm-----	1
39	50-774 Blk.	Stop Pin - Needle Driving Arm -----	1
40	39551 F	Needle Clamp Stud -----	1
43	22564	Screw - Looper Thread Pull-off -----	1
44	39568 A	Looper Thread Pull-off-----	1
45	39568 Y	Looper Thread Pull-off Lever-----	1
46	88 B	Screw - Looper Thread Pull-off Lever -----	2
47	39552 C	Needle Driving Arm Crank Thrust Washer-----	2
48	39552 A	Needle Driving Arm Crank-----	1
49	39552 E	Needle Driving Arm Crank Connecting Rod -----	1
50	22587 J	Screw - Connecting Rod -----	2
51	39594 N	Oil Splasher-----	1
52	77	Screw - Oil Splasher -----	1
53	660-207	Oil Seal Ring -----	1
55	22569 C	Screw - Mounting Bracket -----	2
56	39503 C	Edge Guide Mounting Bracket -----	1
57	22758 E	Screw - Swinging Arm, for Styles 39500 J & L -----	1
58	12957 E	Swinging Arm Spring Washer, for Styles 39500 J & L -----	1
59	39503 D	Edge Guide Swinging Arm, for Styles 39500 J & L -----	1
60	604	Screw - Adjustable Edge Guide, for Styles 35900 J & L ---	2
61	39503 A	Edge Guide, adjustable, for Styles 39500 J & L -----	1
62	22570	Screw - Stationary Edge Guide, for Styles 39500 K & M ----	2
63	39503	Edge Guide, stationary, for Styles 39500 K & M -----	1

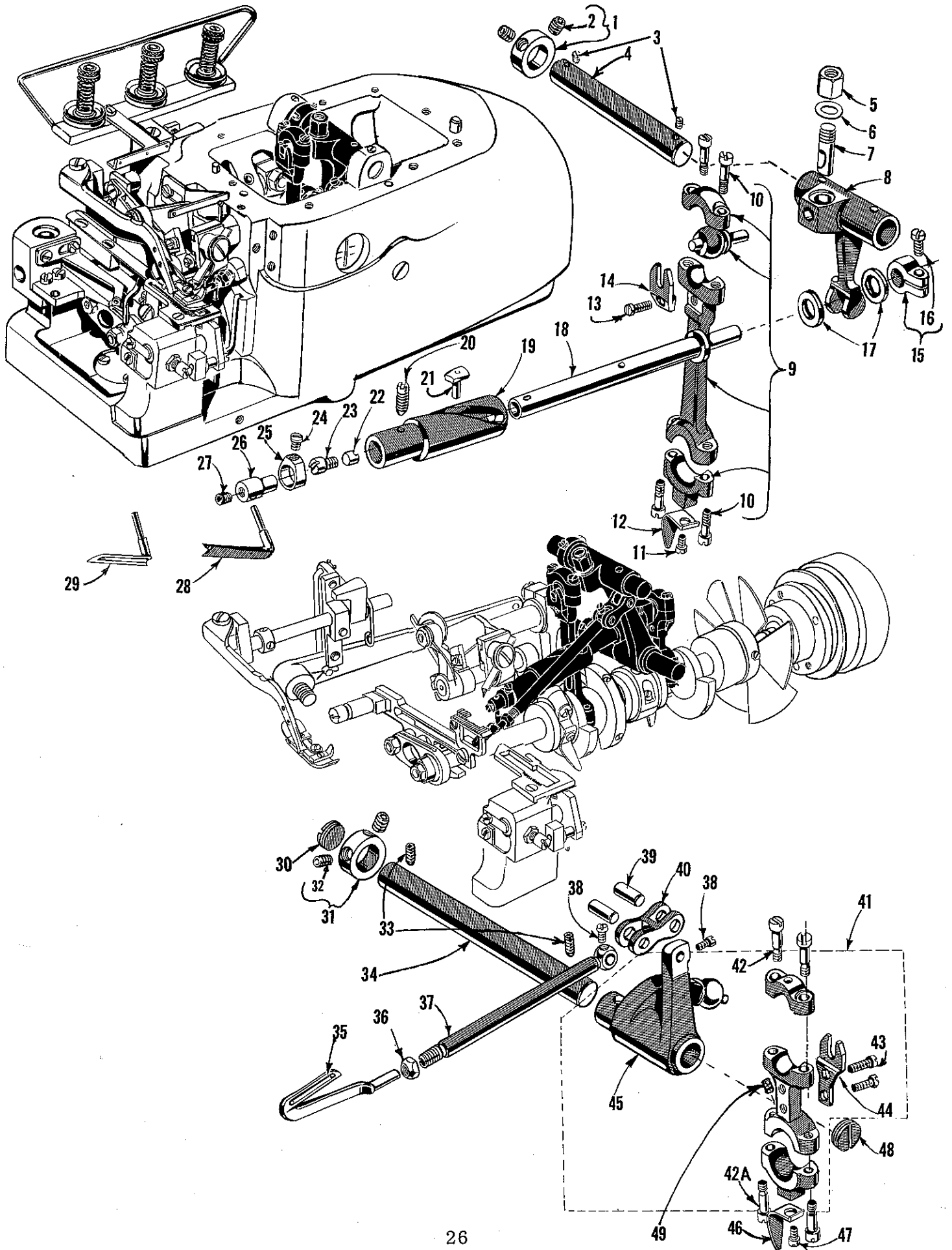

SPREADER/UPPER LOOPER AND LOWER LOOPER DRIVING PARTS

<u>Ref. No.</u>	<u>Part No.</u>	<u>Description</u>	<u>Amt. Req.</u>
1	482 C	Spreader/Upper Looper Shaft Collar-----	1
2	22894 C	Screw - Collar-----	2
3	22565	Screw - Spreader/Upper Looper Drive Lever Shaft-----	2
4	7446 A	Spreader/Upper Looper Drive Lever Shaft-----	1
5	1280	Nut - Locking Stud-----	1
6	39543 R	Locking Stud Washer-----	1
7	43143 N	Locking Stud - Spreader/Upper Looper Drive Lever-----	1
8	39543 H	Spreader/Upper Looper Drive Lever-----	1
9	29126 CG	Spreader/Upper Looper Drive Lever Connecting Rod Assembly-----	1
10	22559 A	Screw - Connecting Rod Assembly-----	4
11	77	Screw - Oil Splasher-----	1
12	39594 N	Oil Splasher-----	1
13	22747	Screw - Guide Fork-----	1
14	41255 B	Ball Joint Guide Fork - Spreader/Upper Looper Drive Assembly-----	1
15	39543 M	Collar Clamp-----	1
16	22562 A	Screw - Collar Clamp-----	1
17	39543 P	Spreader/Upper Looper Shaft Thrust Washer-----	2
18	39543 K	Spreader/Upper Looper Shaft-----	1
19	39543 S	Bushing and Cam Guide-----	1
20	22565 H	Screw - Cam Guide-----	1
21	39543 T	Cam Follower-----	1
22	39543 E	Cam Follower Locking Clamp-----	1
23	22503 F	Screw - Locking Clamp-----	1
24	22 KH	Screw - Spreader/Upper Looper Holder Collar-----	1
25	39543 A	Spreader/Upper Looper Holder Collar-----	1
26	39543	Spreader/Upper Looper Holder-----	1
27	22564 G	Screw - Spreader/Upper Looper Holder-----	1
28	39560 A	Spreader - Styles 39500 J & K-----	1
29	39508 A	Upper Looper - Styles 39500 L & M-----	1
30	22539 K	Plug Screw - Lower Looper Shaft-----	1
31	482 C	Lower Looper Shaft Collar-----	1
32	22894 C	Screw - Collar-----	2
33	22894 AD	Screw - Lower Looper Bar Driving Lever Shaft-----	2
34	51235 B	Lower Looper Bar Driving Lever Shaft-----	1
35	39508 B	Lower Looper-----	1
36	39151	Nut - Lower Looper Bar-----	1
37	39544	Lower Looper Bar-----	1
38	77	Screw - Connection Link Pin-----	2
39	39544 D	Lower Looper Bar Connection Link Pin-----	2
40	39544 B	Lower Looper Bar Connection Link-----	1
41	29126 DF	Lower Looper Bar Driving Lever and Connecting Rod Assembly-----	1
42	22729 D	Screw, upper-----	2
42A	22729 E	Screw, lower-----	2
43	97	Screw, for No. 39544 S-----	2
44	39544 S	Ball Joint Guide Fork-----	1
45	39544 U	Lower Looper Ball Driving Lever-----	1
46	39594 N	Oil Splasher-----	1
47	77	Screw, for No. 39594 N-----	1
48	22539 K	Plug Screw - Lower Looper Shaft-----	1
49	666-255	Felt, for No. 39544 N-----	1
-	39594 P	Oil Collector Plate (Not Illustrated)-----	1

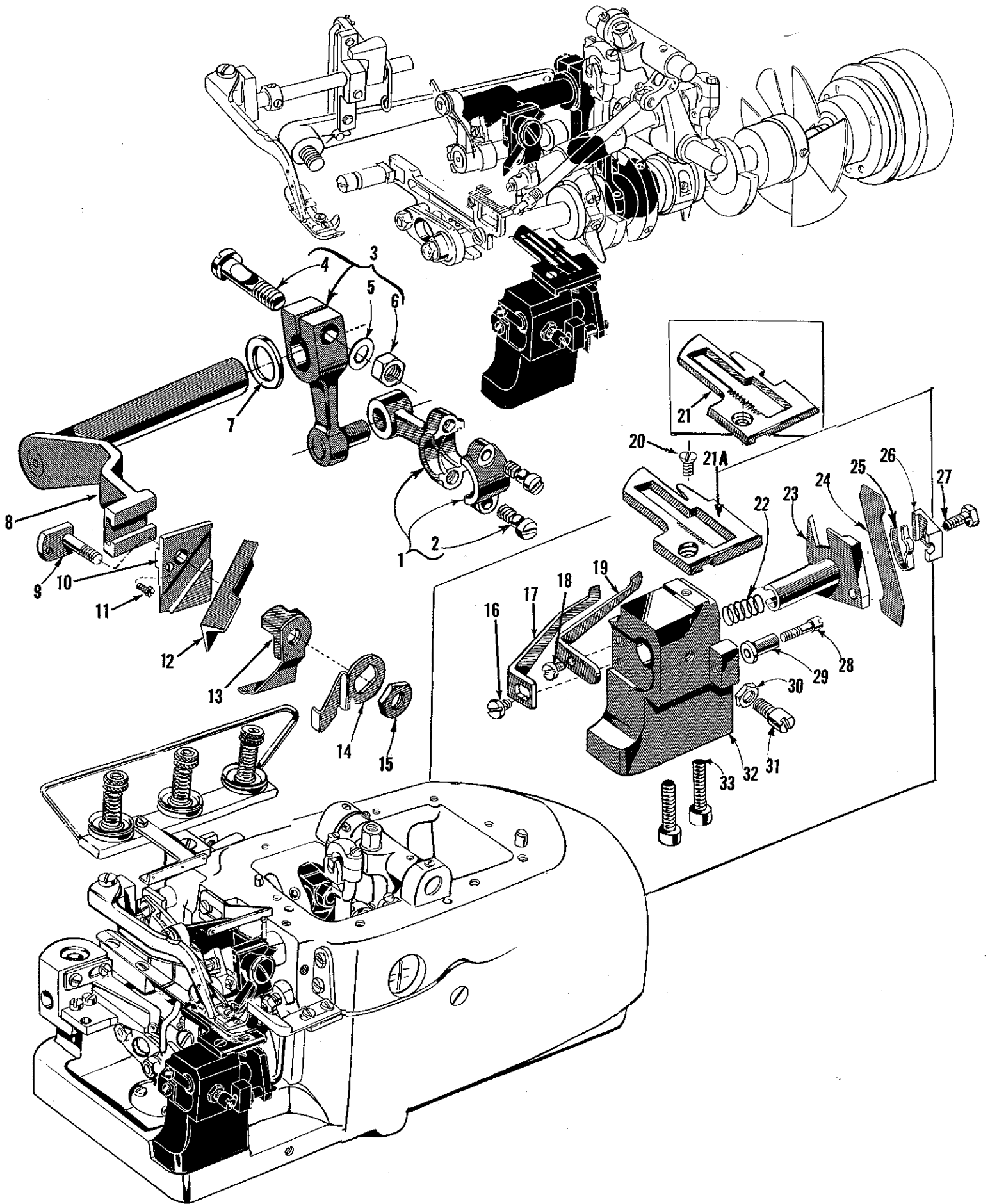

UPPER AND LOWER KNIFE MECHANISM

<u>Ref. No.</u>	<u>Part No.</u>	<u>Description</u>	<u>Amt. Req.</u>
1	39573 J	Upper Knife Driving Connecting Rod -----	1
2	22587 J	Screw - Connecting Rod -----	2
3	39573 E	Upper Knife Driving Lever -----	1
4	55235 D	Locking Stud - Driving Lever -----	1
5	6042 A	Washer - Driving Lever -----	1
6	55235 E	Nut - Driving Lever -----	1
7	39573 A	Upper Knife Driving Arm Washer -----	1
8	39573 H	Upper Knife Driving Arm -----	1
9	39571 C	Upper Knife Clamp Stud -----	1
10	39572 A	Upper Knife Holder Block -----	1
11	22738	Screw - Holder Block - Clamp Nut -----	1
12	39570 J	Upper Knife, for Styles 39500 J & L only -----	1
13	39571 F	Upper Knife Clamp -----	1
14	39571 B	Upper Knife Chain Guard -----	1
15	14077	Nut - Upper Knife Assembly -----	1
16	22585 A	Screw - Needle Guard, front -----	1
17	39525	Needle Guard, front -----	1
18	22585 A	Screw - Needle Guard, rear -----	1
19	39525 A	Needle Guard, rear -----	1
20	22524	Screw - Throat Plate -----	1
21	39524 J	Throat Plate, 3/16 inch wide seam, for Styles 39500 J & L -----	1
21A	39524 K	Throat Plate, 3/16 inch wide seam, for Styles 39500 K & M -----	1
22	39550 E	Lower Knife Spring -----	1
23	39550 B	Lower Knife Holder -----	1
24	39549 J	Lower Knife -----	1
25	39550 M	Knife Clamp Spring -----	1
26	39550 L	Lower Knife Clamp -----	1
27	22588 A	Screw - Lower Knife Holder -----	1
28	22729 B	Screw - Lower Knife Holder Locking Stud -----	1
29	39550 C	Lower Knife Holder Locating Stud -----	1
30	14077	Nut - Locking Screw - Lower Knife Holder -----	1
31	22892 B	Locking Screw - Lower Knife Holder -----	1
32	39580 A	Throat Plate and Lower Knife Support Bracket -----	1
33	22653 B-12	Screw - Support Bracket -----	2

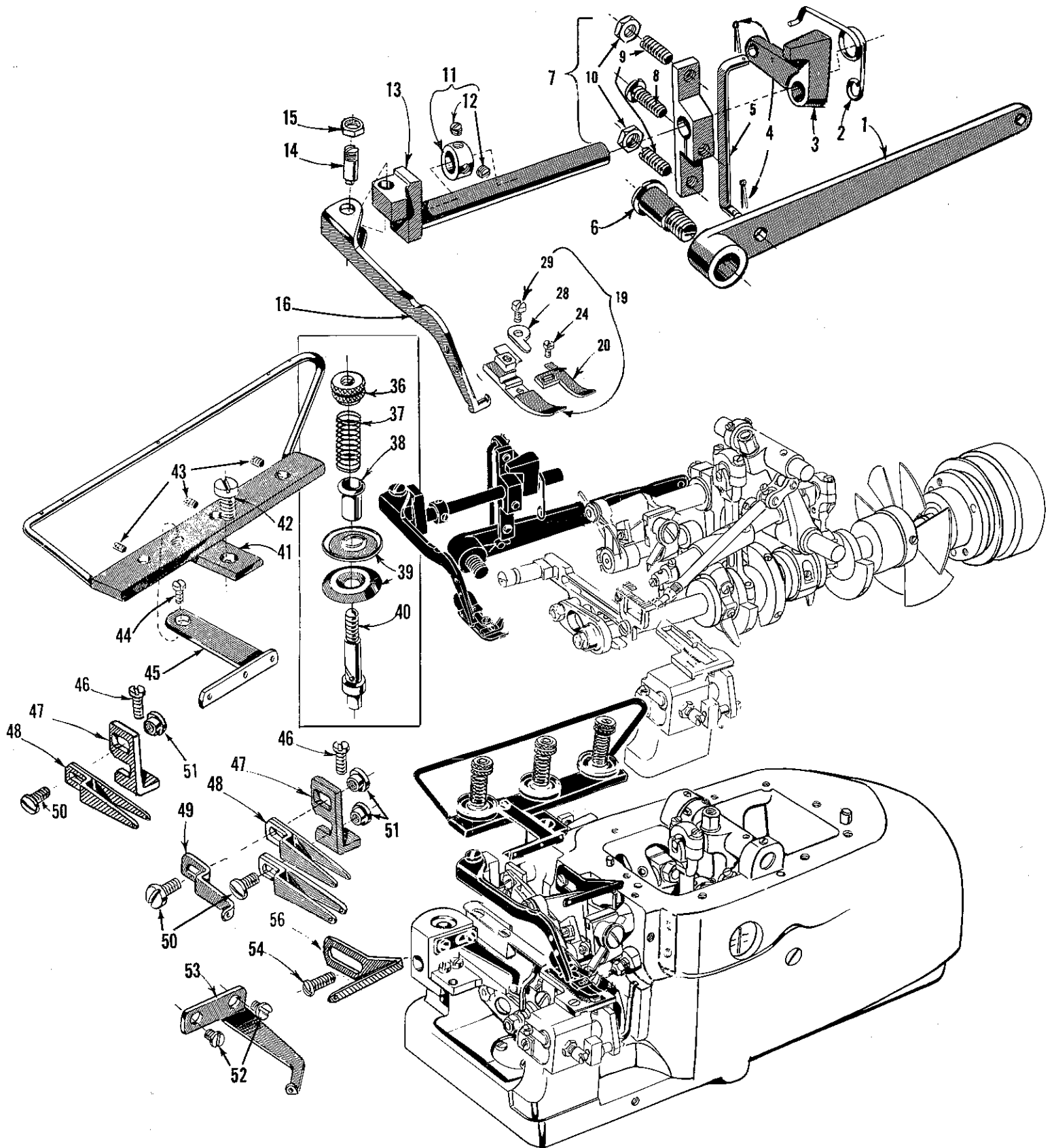

FOOT LIFTER, THREAD TENSIONS AND MISCELLANEOUS EYELETS

<u>Ref. No.</u>	<u>Part No.</u>	<u>Description</u>	<u>Amt. Req.</u>
1	39555	Foot Lifter Lever -----	1
2	39555 B	Foot Lifter Lever Spring -----	1
3	39555 D	Foot Lifter Intermediate Lever -----	1
4	660-142	Cotter Pin - Connecting Link -----	2
5	39555 F	Foot Lifter Lever Connecting Link -----	1
6	22566 B	Screw - Foot Lifter Lever -----	1
7	39555 C	Foot Lifter Lever Arm -----	1
8	627	Screw - Lever Arm -----	1
9	22597 E	Screw - Lever Arm -----	2
10	12538	Lock Nut - Lever Arm -----	2
11	12865	Foot Lifter Lever Shaft Collar -----	1
12	88	Screw - Collar -----	2
13	39555 A	Foot Lifter Lever Shaft -----	1
14	22791 H	Screw - Presser Arm -----	1
15	258 A	Nut - Presser Arm -----	1
16	39556 D	Presser Arm -----	1
19	39520 L	Presser Foot -----	1
20	39597 L	Presser Foot Stitch Tongue -----	1
24	22819	Screw - Stitch Tongue -----	1
28	39530	Presser Foot Hinge Spring -----	1
29	22768 B	Screw - Hinge Spring -----	1
36	108	Tension Post Nut, for Styles 39500 J & K -----	2
	108	Tension Post Nut, for Styles 39500 L & M -----	3
37	51292 F-2	Lower Needle Thread Tension Spring, for Styles 39500 J & K -----	1
	51292 F-2	Lower Looper Thread Tension Spring, for Style 39500 K ----	1
	51292 F-4	Looper Thread Tension Spring, for Style 39500 J -----	1
	51292 F-4	Needle and Upper Looper Thread Tension Spring, for Styles 39500 L & M -----	2
	51292 F-8	Lower Looper Thread Tension Spring, for Styles 39500 L & M -----	1
38	107	Tension Post Ferrule, for Styles 39500 J & K -----	2
	107	Tension Post Ferrule, for Styles 39500 L & M -----	3
39	109	Tension Disc, for Styles 39500 J & K -----	4
	109	Tension Disc, for Styles 39500 L & M -----	6
40	35792 H	Tension Post, for Styles 39500 J & K -----	2
	35792 H	Tension Post, for Styles 39500 L & M -----	3
41	39592 F	Tension Post Mounting Bracket -----	1
42	22891	Screw - Tension Post Mounting Bracket -----	1
43	22565 C	Screw - Tension Post, for Styles 39500 J & K -----	2
	22565 C	Screw - Tension Post, for Styles 39500 L & M -----	3
44	90	Screw - Thread Guide -----	1
45	39563 S	Thread Guide -----	1
46	22569 B	Screw - Eyelet Mounting Bracket -----	1
47	39568 D	Looper Thread Eyelet Mounting Bracket -----	1
48	39568 L	Looper Thread Eyelet -----	1
	39568 B	Looper Thread Eyelet, for Styles 39500 L & M -----	1
49	39568 E	Auxiliary Looper Thread Eyelet, for Styles 39500 L & M ---	1
50	376 A	Screw - Looper Thread Eyelet, for Styles 39500 J & K -----	1
	376 A	Screw - Looper Thread Eyelet, for Styles 39500 L & M ----	2
51	43139 A	Nut - Looper Thread Eyelet, for Styles 39500 J & K -----	1
	43139 A	Nut - Looper Thread Eyelet, for Styles 39500 L & M -----	2
52	73 X	Screw - Frame Thread Guide -----	2
53	39568 W	Frame Thread Guide - Lower Looper Thread -----	1
54	22569 D	Screw - Needle Thread Eyelet -----	1
56	39563 D	Needle Thread Eyelet -----	1

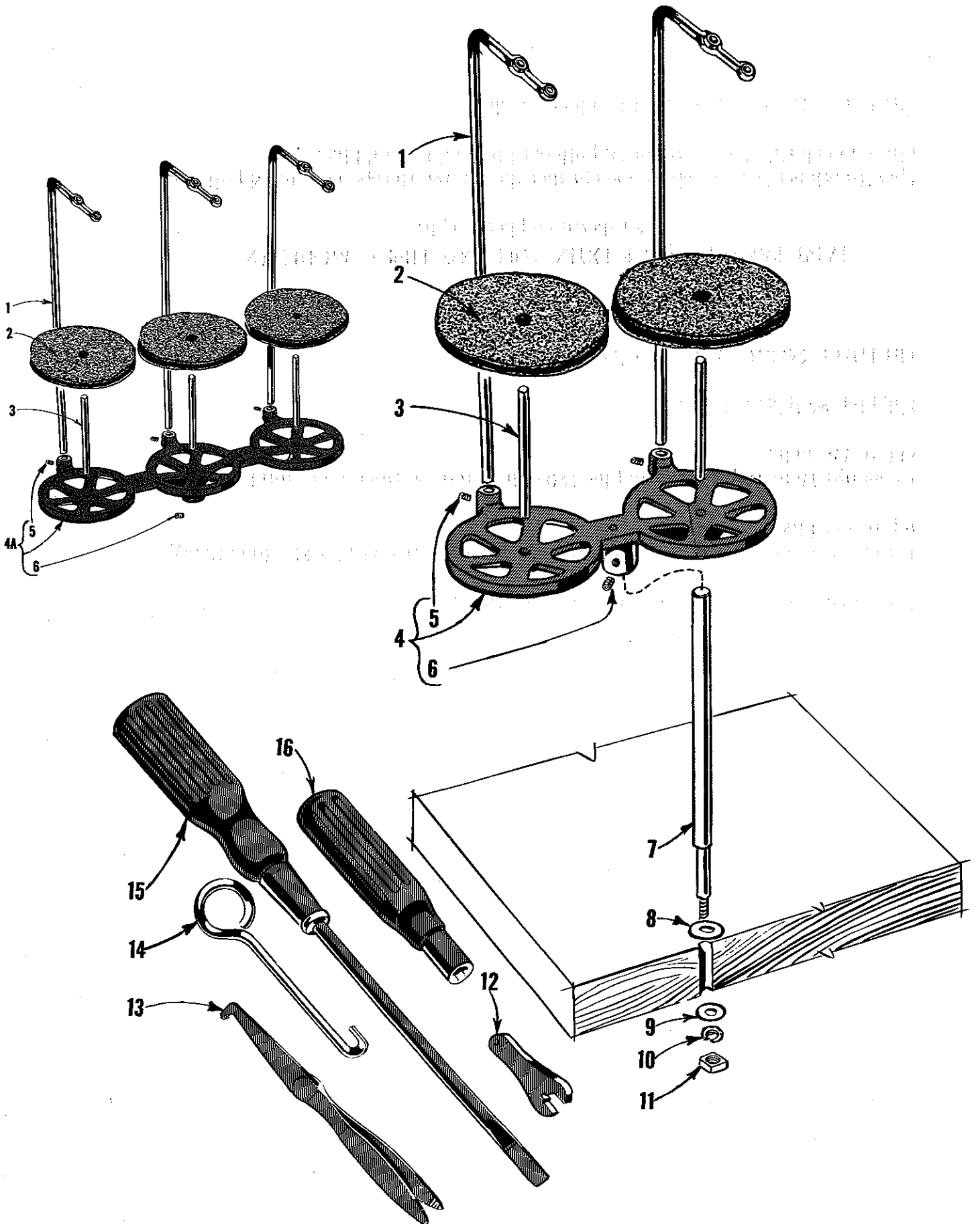

THREAD STAND AND MISCELLANEOUS TOOLS

Ref. No.	Part No.	Description	Amt. Req.
1	21113 F	Thread Eyelet and Support Rod, for Styles 39500 J & K-----	2
	21113 F	Thread Eyelet and Support Rod, for Styles 39500 L & M-----	3
2	21104 V	Pad, for Styles 39500 J & K-----	2
	21104 V	Pad, for Styles 39500 L & M-----	3
3	69 S	Spool Pin, for Styles 39500 J & K-----	2
	69 S	Spool Pin, for Styles 39500 L & M-----	3
4	21130 W-2	Cone Support, for Styles 39500 J & K-----	1
4A	21130 W-3	Cone Support, for Styles 39500 L & M-----	1
5	22650 CB-4	Screw - Cone Support, for Styles 39500 J & K-----	2
	22650 CB-4	Screw - Cone Support, for Styles 39500 L & M-----	3
6	22650 CE-6	Screw - Cone Support, for all Styles-----	1
7	21104 AA	Thread Stand Rod-----	1
8	652 J-24	Washer - Thread Stand Rod-----	1
9	652 J-16	Washer - Thread Stand Rod-----	1
10	WA9 A	Lock Washer-----	1
11	651 A-16	Nut - Thread Stand Rod-----	1
12	116	Wrench, for 9/32 inch nut-----	1
13	660-240	Thread Tweezers-----	1
14	21227 BF	Feed Eccentric Extractor Hook-----	1
*15	21202	Screw Driver, 3/16 inch diameter, 10 3/4 inches long-----	1
16	21388 AU	Socket Wrench, for 3/8 inch nut holding feed eccentrics-----	1

* Not furnished with machine.

ACCESSORIES AVAILABLE AS EXTRAS (Not Illustrated)

21227 BG	Needle Curvature Gauge		
21233 DR	Light Fixture Assembly, including blue lens, machine mounting for machines driven by "Electro Drive" which supplies the current		
21261 M-360	No. 1 "V" Belt, 36 inches long, for fully submerged individual power table installation		
21261 M-380	No. 1 "V" Belt, 38 inches long, for semisubmerged individual power table installation		
21261 M-400	No. 1 "V" Belt, 40 inches long, for nonsubmerged individual power table installation		
21377 BA	Tray, 1 3/4 inches high, for semisubmerged installation		
21377 BF	Tray, 1 3/4 inches high, for semisubmerged installations with front section extended to right		
21695 U	Finger Protector		
39556 B	Presser Arm Chain Cutting Knife, lower		
39556 C	Presser Arm Chain Cutting Knife, upper		
605	Presser Arm Chain Cutting Knife Screws (two needed)		
39595	Isolator, rubber		
39598	Knife Grinder, complete		
52978 J	Chip Disposal Chute		
		Belt Slot to Right Edge of Board	Cloth Plate to Front Edge of Board
21371 UH	Individual Power Table		
21371 PJ-48	Table Top, 48 x 20 x 1 3/4 inches, for individual power table installation: Nonsubmerged - no chip chute	14 inch	3/8 inch
21371 RD-48	Table Top, same except Nonsubmerged	7 1/2 inch	3 inch
21371 RF-48	Table Top, same except Nonsubmerged - no chip chute	7 1/2 inch	3/8 inch
21371 RJ-48	Table Top, same except Semisubmerged	10 1/2 inch	2 1/4 inch
21371 RG-48	Table Top, same except Fully submerged	7 1/2 inch	2 1/4 inch
21371 RK-48	Table Top, same except Fully submerged	10 1/2 inch	2 1/4 inch
21371 RC-47 3/4	Table Top, 47 3/4 x 16 x 1 3/4 inches, for line shaft installations Nonsubmerged - no chip chute	7 1/2 inch	3/8 inch
21371 RE-47 3/4	Table Top, same except Nonsubmerged	7 1/2 inch	3 inch
21371 RH-47 3/4	Table Top, same except Semisubmerged	7 1/2 inch	2 1/4 inch

NUMERICAL INDEX OF PARTS

<u>Part No.</u>	<u>Page No.</u>	<u>Part No.</u>	<u>Page No.</u>	<u>Part No.</u>	<u>Page No.</u>	<u>Part No.</u>	<u>Page No.</u>
WA9 A	33	22565 H	27	39534 H	25	39568 J	21
18	25	22566 B	31	39534 R	21	39568 L	31
20	25	22569	21, 23, 25	39535 C	25	39568 W	31
22 KH	27	22569 A	21	39535 D	25	39568 Y	25
50-774 Blk	25	22569 B	25, 31	39535 F	25	39570 J	29
51-103 Blk	21	22569 C	21, 25	39535 J	25	39571 B	29
69 S	33	22569 D	21, 31	39536 A	25	39571 C	29
73 X	31	22569 G	25	39536 B	25	39571 F	29
77	25, 27	22570	25	39536 C	25	39572 A	29
77 Q	23	22571 E	21	39536 D	25	39573 A	29
86 X	21	22585 A	29	39536 E	25	39573 E	29
87	25	22586 R	21	39538	25	39573 H	29
88	31	22587 J	25, 29	39540 B-5	25	39573 J	29
88 B	25	22588 A	29	39540 J	25	39573 K	23
90	21, 31	22596 E	25	39541	23	39573 AA	23
95	23	22597 E	31	39543	27	39578 F	21
97	27	22650 CB-4	33	39543 A	27	39578 M	25
97 A	23	22650 CE-6	33	39543 E	27	39578 P	25
107	31	22653 B-12	29	39543 H	27	39578 R	25
108	31	22653 D-4	21	39543 K	27	39578 BB	21
109	31	22657 D-12	21	39543 M	27	39580 A	29
116	33	22729 B	29	39543 P	27	39582 F	21
138	21	22729 D	27	39543 R	27	39582 K	21
258 A	31	22729 E	27	39543 S	27	39582 L	21
376 A	31	22738	29	39543 T	27	39582 S	21
482 C	27	22743	21	39544	27	39582 V	21
604	25	22747	27	39544 B	27	39582 X	21
627	31	22747 B	23	39544 D	27	39582 Y	21
651 A-16	33	22758 E	25	39544 L	23	39582 AA	21
652 J-16	33	22768 B	25, 31	39544 S	27	39590	23
652 J-24	33	22769 A	23	39544 U	27	39590 C	23
660-142	31	22791 H	31	39549 J	29	39590 D	23
660-207	25	22819	31	39550 B	29	39590 G	23
660-234	21	22891	31	39550 C	29	39590 H	23
660-240	33	22892 E	29	39550 E	29	39590 J	23
660-243	21	22894 C	27	39550 L	29	39590 N	23
660-268	23	22894 D	23	39550 M	29	39590 P	23
666-94	23	22894 AD	21, 27	39551 F	25	39590 R	23
666-255	27	29126 CG	27	39552	25	39590 S	23
1280	27	29126 DF	27	39552 A	25	39590 T	23
6042 A	29	29477 GW	21	39552 B	23	39591 A	23
7446 A	27	35792 H	31	39552 C	25	39591 B	23
8372 A	25	39142 G	23	39552 E	25	39591 H	23
12538	31	39151	27	39555	31	39591 L	23
12865	31	39501	21	39555 A	31	39592 F	31
12957 E	25	39501 A	21	39555 B	31	39593 C	21
14077	25, 29	39501 B	21	39555 C	31	39593 D	21
21104 V	33	39501 C	21	39555 D	31	39593 E	21
21104 AA	33	39501 K	21	39555 E	23	39594 A	21
21113 F	33	39503	25	39555 F	31	39594 G	21
21130 W-2	33	39503 A	25	39556 A	21	39594 H	21
21130 W-3	33	39503 C	25	39556 D	31	39594 N	25, 27
21202	33	39503 D	25	39557	21	39594 P	27
21227 BF	33	39505 J	25	39557 A	21	39597 L	31
21388 AU	33	39505 K	25	39557 B	21	39691	23
22503 F	27	39508 A	27	39557 C	21	41071 G	21
22524	29	39508 B	27	39557 E	21	41255 B	27
22528	25	39520 L	31	39557 F	21	43139 A	31
22539 K	27	39521	23	39560 A	27	43143 N	27
22541	21	39521 A	23	39563 D	31	51235 B	27
22559 A	27	39524 J	29	39563 S	31	51292 F-2	31
22562 A	27	39524 K	29	39563 Z	25	51292 F-4	31
22564	25	39525	29	39568 A	25	51292 F-8	31
22564 G	27	39525 A	29	39568 B	31	53634 C	25
22565	21, 27	39530	31	39568 D	31	55235 D	29
22565 C	31	39532 A	21	39568 E	31	55235 E	29
22565 F	23, 25	39534 G	25	39568 G	21		

Here are Oil Specifications for Union Special Sewing Machines



Specification 174 specifies a high quality petroleum oil, viscosity 100 seconds at 100°F. Recommended for all oiling applications on high speed machines.

Specification 175 specifies a high quality petroleum oil, viscosity 100 seconds at 100°F., water white or with a maximum A.S.T.M. color number of 1. For use where freedom from oil staining is paramount.

Specification 87 specifies a high quality petroleum oil, viscosity 300 seconds at 100°F.

Specification 100 specifies a general purpose high quality grease for use in ball bearings and transmitters. It is similar to commercial N.L.G.I., grease No. 3. Where No. 3 grease is not obtainable, No. 2 may be used.

UNION SPECIAL

SPECIFICATION NO.	174	175	87
Viscosity S.S.U. at 100°F	90-125	90-125	300-350
Flash (Min.)	350	350	350
Pour (Max.)	20	20	20
Color A.S.T.M. (Max.)	3	1	3
Neutralization No. (Max.)	0.10	0.10	0.10
Viscosity Index (D & D Min.)	85	85	85
Compounding	None	None	None
Copper Corrosion (Max.)	1A	1A	1A

*Anline No. 175-225 175-225 175-225

*Used with Buna N Rubber "O" Retainers

NOTE 1: The use of non-corrosive additives in oils meeting above classification is desirable but not essential. These may include:

1. Oxidation inhibitors
2. Rust inhibitors
3. Lubricity additives
4. Anti-oxidants
5. Film strength additives

These additives must be completely soluble in the oil and not removable by wick feeding nor shall they separate.

NOTE 2: Oils containing the following type additives shall not be used at any time:

1. Extreme pressure additives—corrosive
2. Tackiness or adhesive additives
3. Lead soap additives
4. Detergents

 **Union Special**[®]
FINEST QUALITY **MACHINE COMPANY**

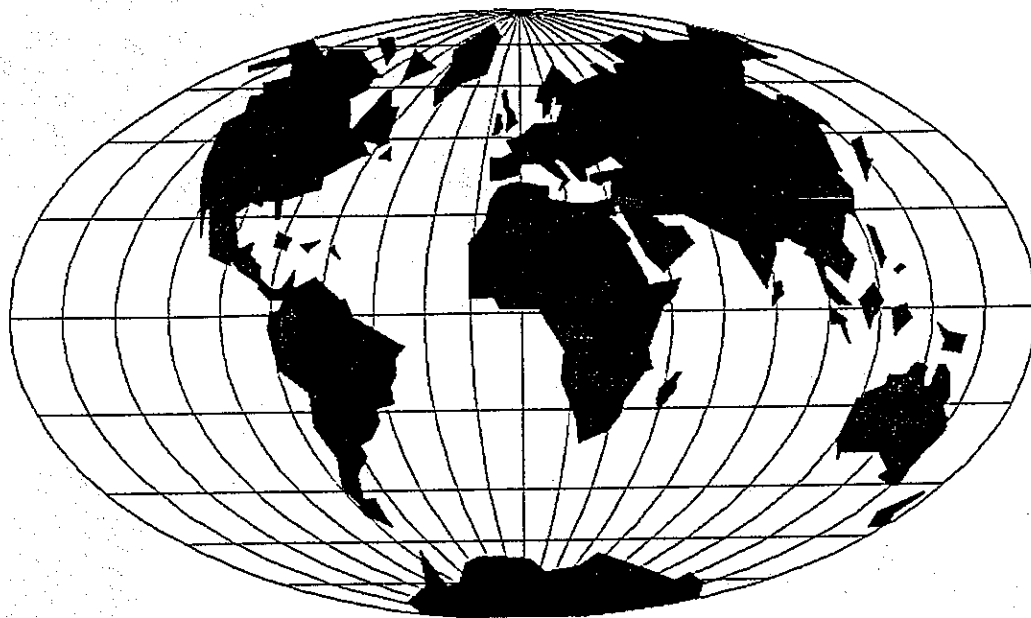

WORLDWIDE SALES AND SERVICE

Union Special Corporation maintains sales and service facilities throughout the world. These offices will aid you in the selection of the right sewing equipment for your particular operation. Union Special Corporation representatives and service technicians are factory trained and are able to serve your needs promptly and efficiently. Whatever your location, there is a qualified representative to serve you.

Brussels, Belgium
Charlotte, N.C.
El Paso, TX
Hong Kong, China
Huntley, IL
Leicester, England
Lille, France
Miami, FL
Milan, Italy
Möglingen, Germany
Montreal, Quebec
Osaka, Japan
Santa Fe Springs, CA

Other Representatives throughout
all parts of the world.

Finest Quality

Union Special
INDUSTRIAL SEWING EQUIPMENT