

# *Union Special*

INDUSTRIAL SEWING EQUIPMENT

## ILLUSTRATED PARTS LIST

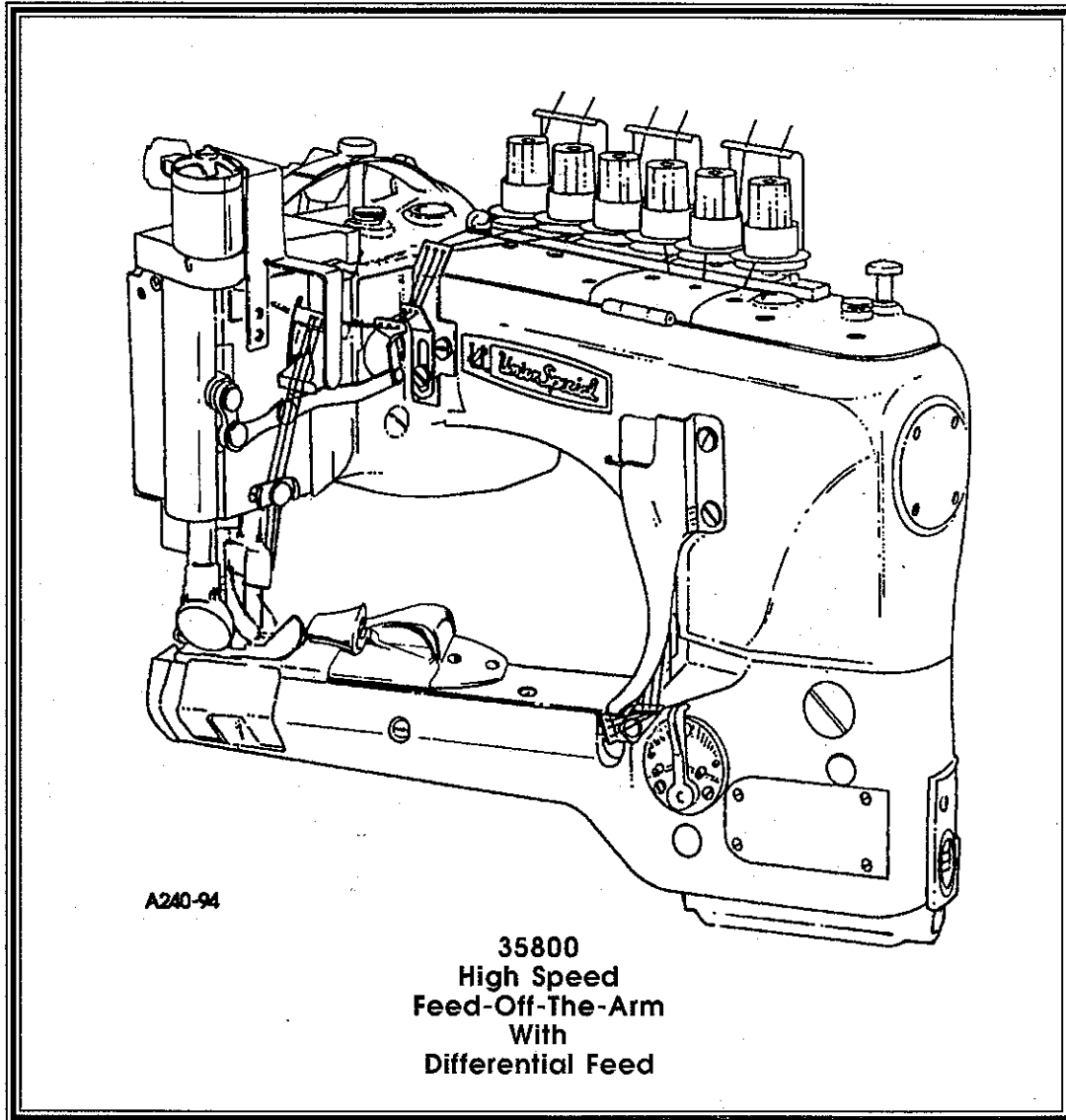

**MANUAL NO. PT9407**

**STYLES**

**35800DLW  
35800DWW  
35800DWWL**

# Manual No. PT9407 Illustrated Parts List for 35800 Series Machines

---

Sixth Edition Copyright 1994

By

Union Special Corporation Rights Reserved In All Countries

Printed in U.S.A. August 1994

---

## PREFACE

This parts manual has been prepared to assist you in locating individual parts or assemblies on 35800 Series machines. It can be used in conjunction with Union Special Adjusting Manual IN9406.

It is the desire of Union Special that each machine run at its optimum performance. Parts listed in this manual are designed specifically for your machine and are manufactured with utmost precision to assure long lasting service.

This manual has been comprised on the basis of available information. Changes in design and/or improvements may incorporate a slight modification of configuration in illustrations or part numbers.

On the following pages are illustrations and terminology used in describing the parts used on 35800 Series machines.

---

## SAFETY RULES



### General Operating Directions

The sewing machines described in this instruction manual are prohibited from being put into service until it has been ascertained that the sewing units, in which these sewing machines will be built-in have conformed with the EC Council Directives (89/392/EEC, Annex II B).

1. Before putting the machines described in this manual into service, carefully read the instructions. The starting of each machine is only permitted after taking notice of the instructions and by qualified operators.

**IMPORTANT!** Before putting the machine into service, also read the safety rules and instruction from the motor supplier.

2. Observe the national safety rules valid for your country.
3. Each machine is only allowed to be used as foreseen. The foreseen use of the particular machine is described in paragraph "STYLES OF MACHINES" of this instruction manual. Another use, going beyond the description, is not as foreseen.
4. All safety devices must be in position when the machine is ready for work or in operation. Operation of the machine without the appertaining safety devices is prohibited.
5. The following safety devices are components of the sewing machines: Sewing guard, needle lever eyelet guard, needle bar guard, needle break protection shield and handwheel-belt guard.
6. When gauge parts are exchanged (i.e. needle, presser foot, needle plate, feed dog and bobbin), during threading, when the operator leaves the workplace, during service work, the machine must be isolated form the mains by switching off the main switch or disconnecting the main plug. On mechanically operated clutch motors without a start inhibitor it is necessary to wait until the motor has stopped.

7. Wear safety glasses.
8. In case of machine conversions and changes all valid safety rules must be considered. Conversions and changes are made at your own risk.
9. Commissioning of the sewing head is prohibited until such time as the entire sewing unit is found to comply with EC regulations.
10. The warning hints in the instructions are marked with one of these two symbols:



Items require special attention



Danger of injury to operative or service staff

Be sure to observe and adhere to these indications and to the generally applicable regulations.

### Special Operating Directions

11. For the following the machine has to be disconnected from the power supply by turning off the main switch or by pulling out the mains plug:
  - 11.1 For threading needle(s), looper, spreader etc.
  - 11.2 For replacing sewing tools such as needle, presser foot, throat plate, looper, spreader, feed dog, needle guard, folder, fabric guide etc.
  - 11.3 When leaving the workplace and when the workplace is unattended.
  - 11.4 For maintenance work.
  - 11.5 When using clutch motors without actuation lock, wait until the motor is stopped totally.

### General Maintenance Directions

12. Maintenance, repair and conversion work (see item 8) must be done only by trained technicians or special skilled personnel under consideration of the instructions.
13. Any work on the electrical equipment must be done by an electrician or under direction and supervision of special skilled personnel.

### Special Maintenance Directions

14. Work on parts and equipment under electrical tension is not permitted.
15. Before doing maintenance and repair work on the pneumatic equipment, the machine has to be disconnected from the compressed air supply. In case of existing residual air pressure after disconnecting from compressed air supply (e.g. pneumatic equipment with air tank), the pressure has to be removed by bleeding.

Exceptions are only allowed for adjusting work and function checks done by special skilled personnel.

### Standards

17. The sewing machines described in this manual are built according to the following standards:
  - EN292-2 Safety of machinery-basic concepts, general principles for design.
  - IEC204-3-1/EN60204-3-1 Electrical equipment of industrial machines. Part 3: Particular requirements for sewing machines, units and systems.

## CONTENTS

•IDENTIFICATION OF MACHINES .....	5
•CLASS DESCRIPTION .....	5
•STYLE OF MACHINES .....	5
•ILLUSTRATIONS .....	5
•ILLUSTRATIONS (CONT.) .....	6
•IDENTIFYING PARTS .....	6
•NEEDLES .....	6
•TERMS .....	6
<b>EXPLODED VIEWS</b>	
•MAIN FRAME, CAST-OFF PLATE, EYELETS, MISCELLANEOUS COVERS AND BUSHINGS .....	9
•MAIN FRAME, CAST-OFF PLATE, EYELETS, MISCELLANEOUS COVERS AND BUSHINGS (CONT.) .....	11
•DIFFERENTIAL FEED CONTROL, CYLINDER COVERS AND BUSHINGS (ALL GAUGES) .....	13
•DIFFERENTIAL FEED CONTROL, CYLINDER COVERS AND BUSHINGS (CONT.) (ALL GAUGES) .....	15
•NEEDLE BAR, NEEDLE HEAD, DETACHABLE HEAD AND MISCELLANEOUS COVERS .....	17
•MISCELLANEOUS OILING, NEEDLE LEVER, CRANKSHAFT AND MAIN SHAFT PARTS (ALL GAUGES) .....	19
•DIFFERENTIAL FEED BAR, MAIN FEED BAR, FEED LIFT ECCENTRIC ASSEMBLY (ALL GAUGES) .....	21
•LOOPERS, LOOPER HOLDERS, FEED DRIVE ASSEMBLY AND LOOPER AVOID ASSEMBLY .....	23
•LOOPERS, LOOPER HOLDERS, FEED DRIVE ASSEMBLY AND LOOPER AVOID ASSEMBLY (CONT.) .....	25
•UPPER ROLLER FEED, FOOT LIFTER AND THREAD TENSION PARTS .....	27
•UPPER ROLLER FEED, FOOT LIFTER AND THREAD TENSION PARTS (CONT.) .....	29
•PULLEY, CRANKSHAFT, CLUTCH AND CLUTCH DRIVING MECHANISM .....	31
•PULLEY, CRANKSHAFT, CLUTCH AND CLUTCH DRIVING MECHANISM (CONT.) .....	33
•PRESSER FOOT, THROAT PLATE, FEED DOGS .....	35
•THREAD STAND .....	37
•ACCESSORIES .....	38
•NOTES .....	39
•NOTES .....	40
•NOTES .....	41
•NUMERICAL INDEX OF PARTS .....	42
•NUMERICAL INDEX OF PARTS .....	43

## IDENTIFICATION OF MACHINES

Each Union Special machine carries a style number, which on this class machine is stamped in the style plate affixed to the right front of the machine.

The serial number is stamped in the casting at the right rear base of machine.

### CLASS DESCRIPTION

High Speed, Feed-Off-The-Arm High Throw Machines, Two or Three Needle, Left Needle In Front, Operator Controlled Differential Feed. Light Weight Presser Bar Mechanism, Adjustable Loper Avoid, Space in Front of Needles 8" (203.2mm), Single Disc Loper Thread Take-Up, Automatic Enclosed Type Oiling System and Filter Type Oil Pump, Visual Sight Oil Action and Supply Gauges, .558" (9/16", 14MM) wide roller.

### STYLE OF MACHINES

**35800DLW**            **DOUBLE LAP SEAM.** Three needle, low capacity, differential feed with upper driven roller feed (wide roller). -Typical Application- For in and seams on medium weight denim garments. Seam Specification 401 LSc-3. Standard gauge Number 9 (9/64", 3.6mm). Recommended needle 130GS, size 125/049. Maximum recommended speed 4500 R.P.M.. .040 step parts.

**35800DWW**            **DOUBLE LAP SEAM.** Two and three needle, high capacity differential feed, high lift feed eccentric, with upper driven, roller feed (wide roller). Feeds have higher teeth on front of feeds. - Typical Application- For use on heavy weight denim garments. Seam Specifications 401 LSc-2 or 401 LSc-3. Standard gauge Numbers 8 (1/8", 3.2mm), 9 (9/64", 3.6mm), 18 (9/32", 7.2mm). Recommended needle 130GS, size 140/054. Maximum recommended speed 4500 R.P.M.. .094 step parts.

NOTE: 18 gauge available with two needles only.

**35800DWWL**            **DOUBLE LAP SEAM.** Same as 35800DWW without the folder. Two and three needle, high capacity differential feed, high lift feed eccentric with upper driven roller feed (wide roller). Feeds have higher teeth on front of feeds. - Typical Application- For use on heavy weight denim garments. Seam Specifications 401 LSc-2 or 401 LSc-3. Standard gauge Numbers 8 (1/8", 3.2mm), 9 (9/64", 3.6mm), 18 (9/32", 7.2mm). Recommended needle 130GS size 140/054. Recommended speed 4500 R.P.M.. .094 step parts.

NOTE: 18 gauge available with two needles only.

### ILLUSTRATIONS

This manual has been arranged to simplify ordering repair parts. Exploded views of various sections of the mechanism are shown so that the parts may be seen in their actual position in the machine. On the page opposite the illustration will be found a listing of the parts with their part numbers, description and the number of pieces required in the particular view being shown.

Numbers in the first column are reference numbers only, and merely indicate the position of the part in the illustration. The reference number should never be used in ordering parts. Always use the part number listed in the second column.

Component parts of sub-assemblies which can be furnished for repairs are indicated by indenting their descriptions under the description of the main sub-assembly. As an example refer to the following text.

9.	29126 EC	Upper Loper Drive Shaft Assembly .....	1
10.	22503 F	Screw .....	1
11.	39543 E	Cam Follower Locking Clamp .....	1

## ILLUSTRATIONS (CONT.)

It will be noted in the previous example that the cam follower, bushing and cam guide and the upper looper drive shaft are not listed. The reason is that replacement of these parts individually is not recommended, so the complete upper looper drive shaft assembly should be ordered.

When a part is common to all machines covered in this manual, no specific usage will be mentioned in the description. However, when the parts for the various machines are not the same, the specific usage will be mentioned in the description and, if necessary, the difference will be shown in the illustration.

A numerical index of all the parts shown in this manual is located at the back. This will facilitate locating the illustration and description when only a part number is known.

## IDENTIFYING PARTS

Where the construction permits, each part is stamped with its part number. On some of the smaller parts and on those where construction does not permit, an identification letter is stamped in to distinguish the part from similar ones.

**PLEASE NOTE:** Part numbers represent the same part, regardless of which manual they appear. On all orders please include part number, name and style of machine for which the part was ordered.

## NEEDLES

Each needle has both a type and size number. The type number denotes the kind of shank, point, length, groove, finish and other details. The size number, stamped on the needle shank, denotes the largest diameter of the blade measured between the shank and the eye. Collectively, the type number and size number represent the complete symbol which is given on the label of all needles packed and sold by Union Special.

### TYPE

### DESCRIPTION

130 GS	Short, double groove, struck groove, ball eye, spotted, government point, chromium plated- Sizes available 080/032, 090/036, 100/040, 110/044, 125/049, 140/054, 150/060.
--------	---

To have needles promptly and accurately filled, an empty package, a needle sample, or the type and size number should be forwarded. Use the description on the label. A complete order should read as follows: "100 needles, type 130 GS, size 125/049".

### TERMS

Prices are net cash and subject to change without notice. All shipments are forwarded F.O.B. shipping point. A charge is made to cover postage and insurance.

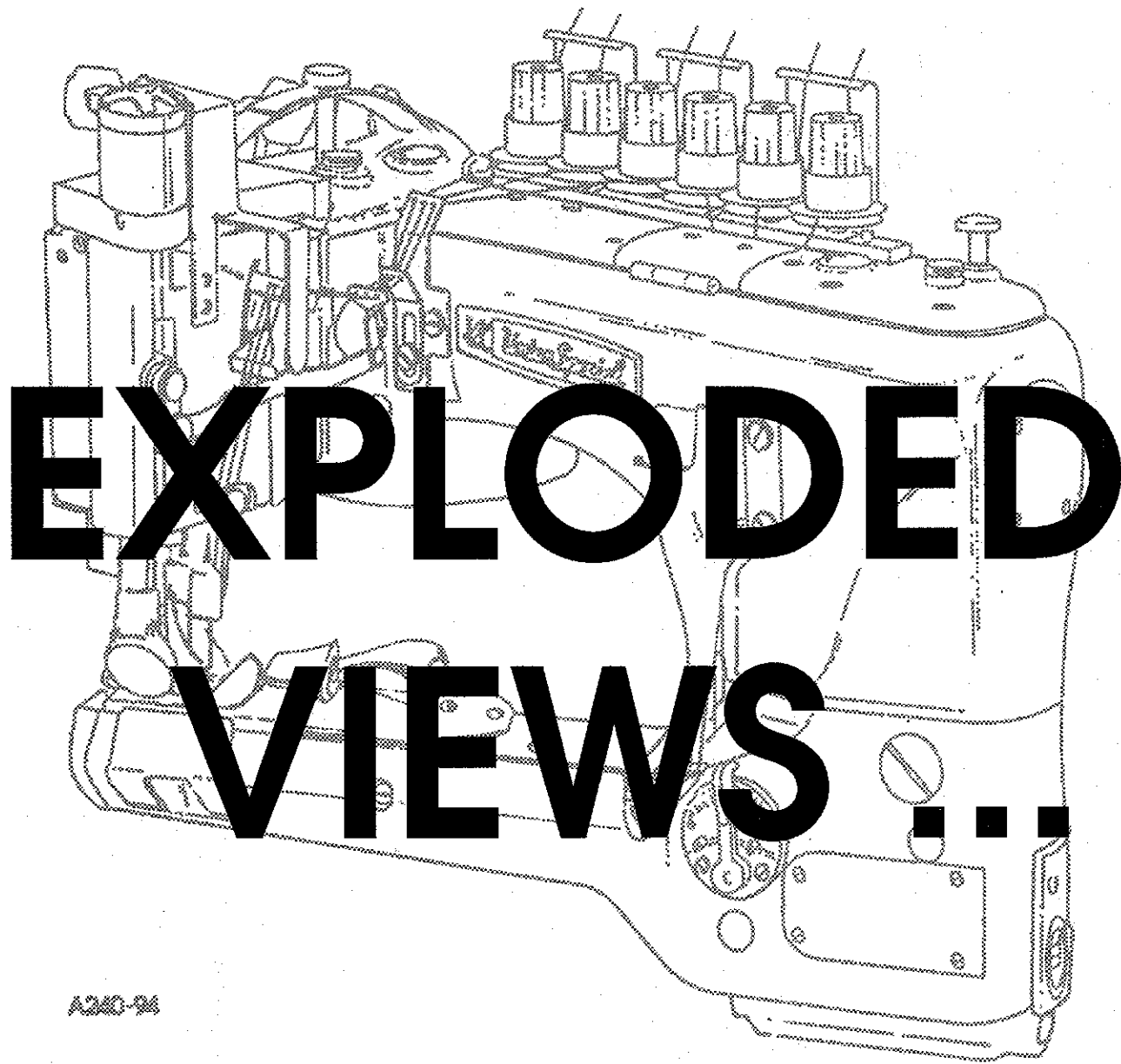

# EXPLODED VIEWS

A240-94

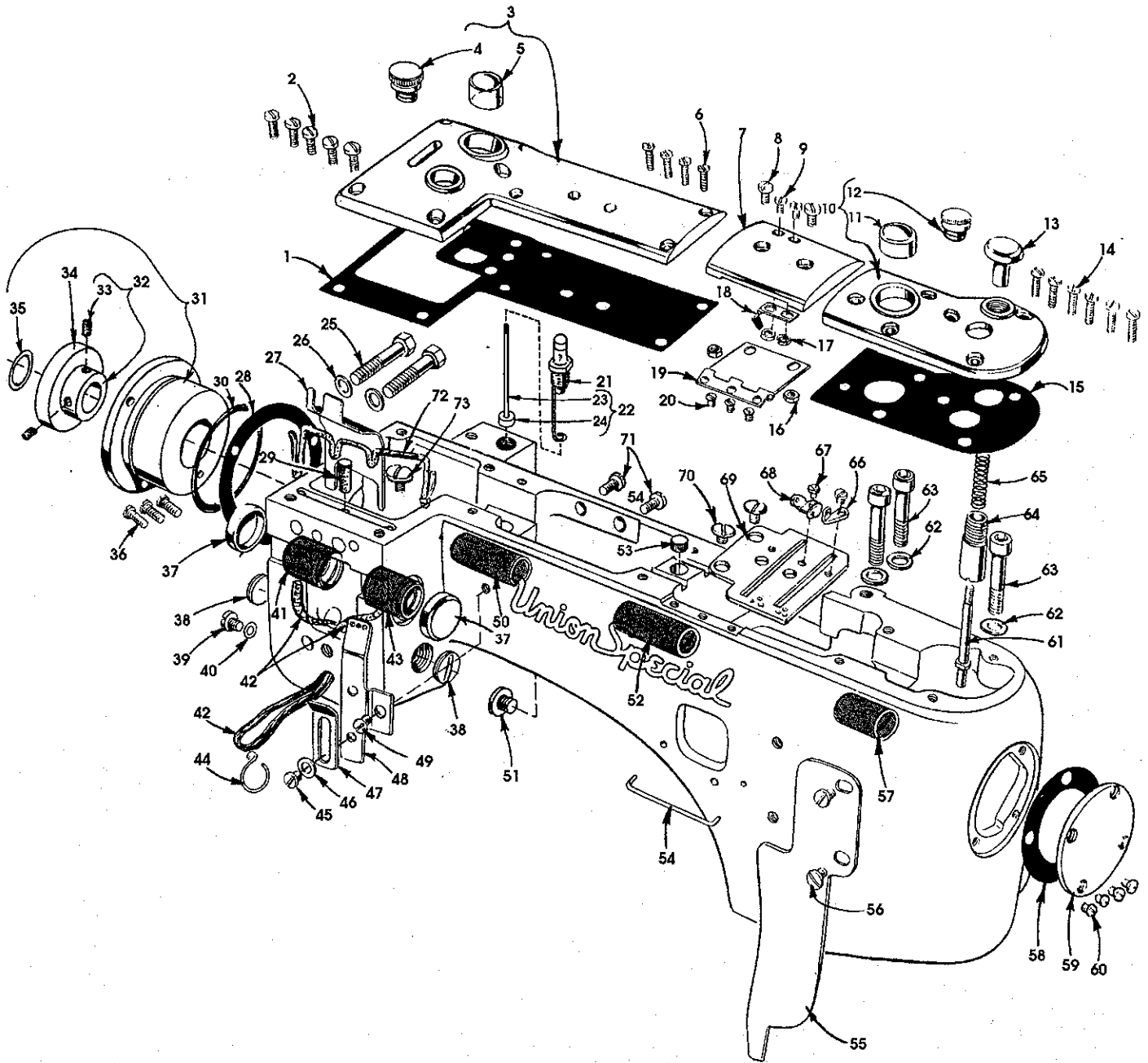

P180-94



MAIN FRAME, CAST-OFF PLATE, EYELETS, MISCELLANEOUS COVERS AND BUSHINGS

Ref. No.	Part No.	Description	Amt. Req.
1.	35888 P	Gasket .....	1
2.	93	Screw .....	5
3.	35888 NR	Crank Chamber Cover .....	1
4.	18-1426	Screw .....	1
5.	50-537 BLK	Oil Sight Gauge .....	1
6.	22516 A	Screw .....	4
7.	35887 X	Top Cover, middle .....	1
8.	93 A	Screw .....	2
9.	90	Screw .....	2
10.	35887 AE	Top Cover, front .....	1
11.	50-537 BLK	Oil Sight Gauge .....	1
12.	18-1426	Screw .....	1
13.	35853 Z	Looper Throw-Out Plunger Knob .....	1
14.	22516 A	Screw .....	6
15.	35887 AD	Gasket .....	1
16.	12934 A	Nut .....	2
17.	41071 G	Nut .....	2
18.	35887 M	Spring .....	1
19.	35887 R	Middle Top Cover Hinge .....	1
20.	22564 B	Screw .....	3
21.	36293 B	Oil Sight Gauge .....	1
22.	36293 F	Oil Sight Gauge Indicator Assembly .....	1
23.	36293 E	Oil Sight Indicator .....	1
24.	39593 C	Oil Gauge Float .....	1
25.	22759 A	Screw .....	2
26.	6042 A	Washer .....	2
27.	35889 H	Oil Shield .....	1
28.	56390 E	Gasket .....	1
29.	C 067 E	Cork .....	1
30.	<del>660-1014</del>	"O" Ring <i>660-935</i> .....	1
31.	35890 M	Bearing Housing Assembly .....	1
32.	35890 L	Shaft Coupling .....	1
33.	22894 F	Screw .....	2
34.	660-1016	Bearing .....	1
35.	<del>660-206</del>	"O" Ring <i>660-1014</i> .....	1
36.	22569 B	Screw .....	3
37.	35761 D	Bushing Cap, plastic .....	2
38.	22539 T	Plug Screw .....	2
39.	22733 B	Oil Drain Screw .....	1
40.	<del>660-935</del>	"O" Ring <i>660-206</i> .....	1
41.	35760 E	Needle Lever Shaft Bushing, rear .....	1
42.	CL 21	Oil Wick .....	2
43.	35760 D	Needle Lever Shaft Bushing, front .....	1
44.	35897 AW	Oil Wicking Hook, upper .....	1
45.	22570	Screw .....	1
46.	8372 A	Washer .....	1
47.	35871 A	Needle Thread Eyelet, three holes .....	1
48.	35871 B	Needle Thread Eyelet, three holes .....	1
49.	22570 A	Screw .....	1
50.	thru 73. See following page		

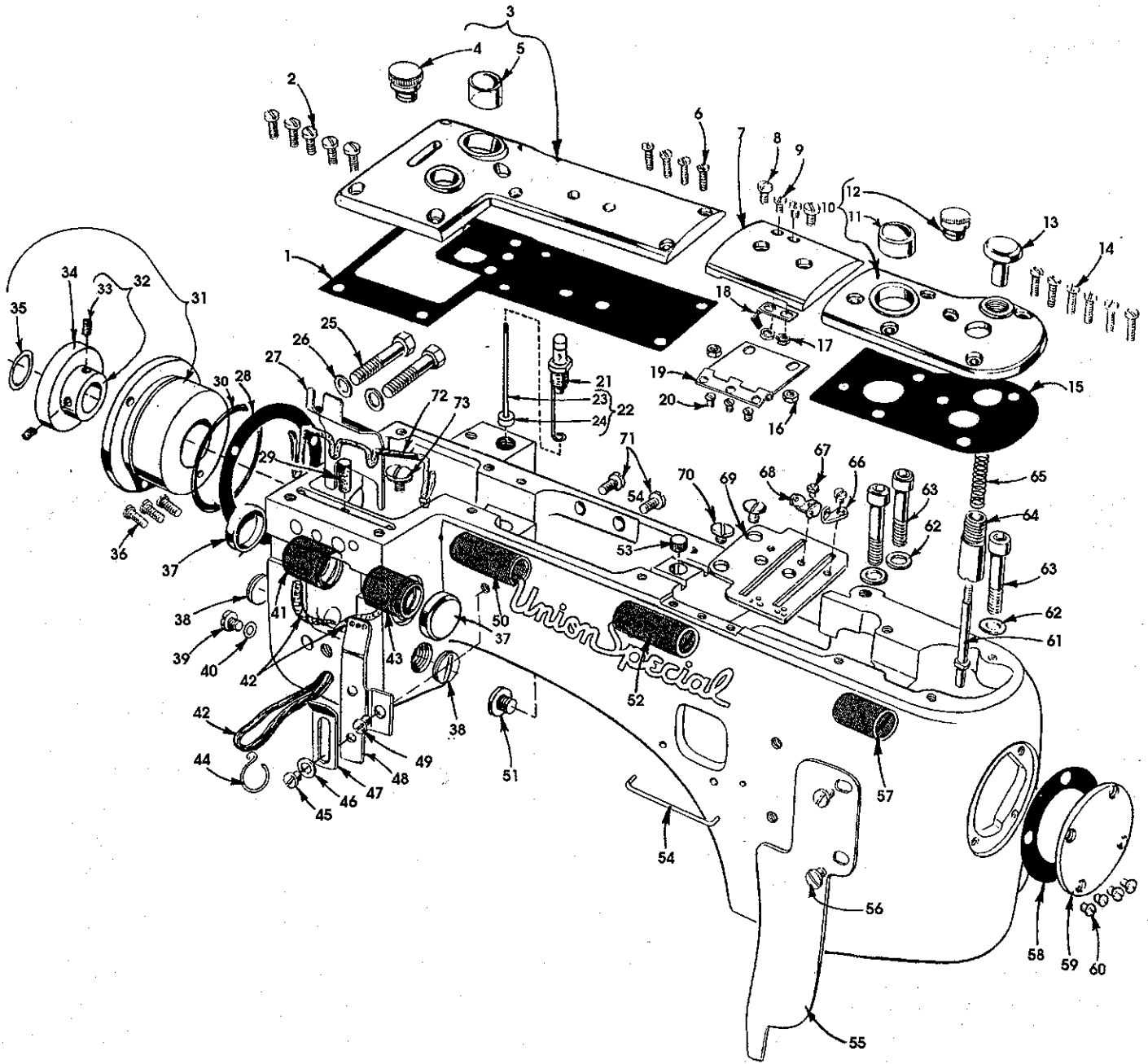

P180-94

MAIN FRAME, CAST-OFF PLATE, EYELETS, MISCELLANEOUS COVERS AND BUSHINGS (CONT.)

Ref. No.	Part No.	Description	Amt. Req.
	1. thru 49. See preceding page		
50.	35890 E	Crankshaft Bushing, front .....	1
51.	22733 B	Main Shaft Bushing, rear .....	1
52.	35890 D	Plug Screw .....	1
53.	50-539 BLK	Plug .....	1
54.	35781 D	Looper Thread Guide Wire .....	1
55.	35856 AA	Looper Thread Shield .....	1
56.	22829	Screw .....	2
57.	36290 B	Main Shaft Bushing, front .....	1
58.	35887 V	Gasket .....	1
59.	35887 Z	Main Frame End Cover .....	1
60.	22564 B	Screw .....	4
61.	35853 W	Looper Throw-Out Plunger .....	1
62.	35876 U	Washer .....	3
63.	22653 E-20	Screw .....	3
64.	35853 AA	Looper Throw-Out Plunger Bushing .....	1
65.	35853 Y	Looper Throw-Out Plunger Spring .....	1
66.	35772 T	Cast-Off Plate Eyelet, front .....	1
67.	28	Screw .....	2
68.	35772 S	Cast-Off Plate Eyelet, rear .....	1
69.	35704 C	Cast-Off Plate .....	1
70.	22730	Screw .....	2
71.	93	Screw, for rotary pump housing .....	2
72.	CL 21	Oil Wick .....	1
73.	22711	Screw, for oil wick .....	1

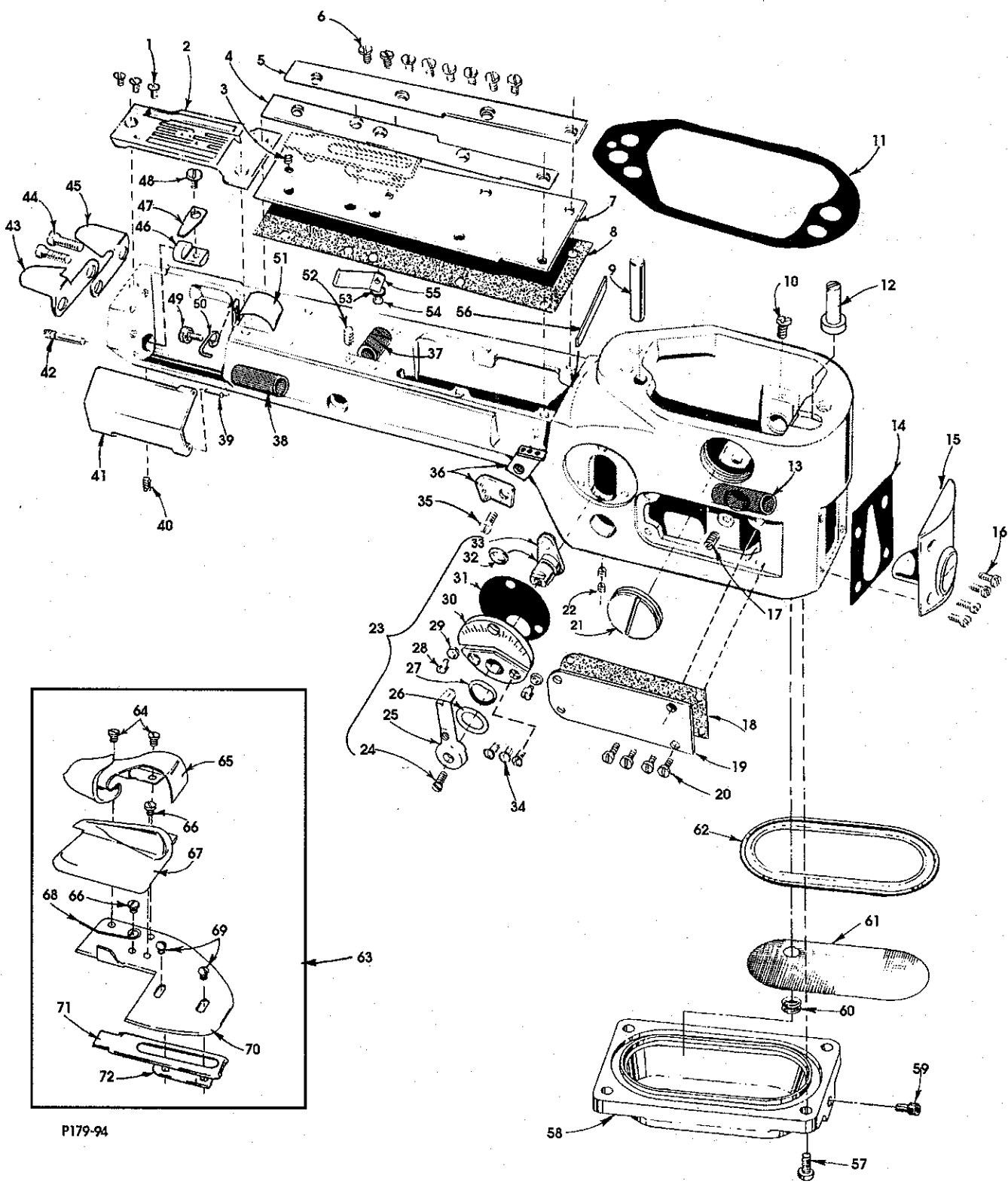

P179-94

**DIFFERENTIAL FEED CONTROL, CYLINDER COVERS AND BUSHINGS (ALL GAUGES)**

Ref. No.	Part No.	Description	Amt. Req.
1.	22524	Screw .....	3
2.	-----	Throat Plate (see page 35) .....	1
3.	22798	Screw .....	1
4.	35883 N	Folder Gib, left .....	1
5.	35883 P	Folder Gib, right .....	1
6.	22564 J	Screw .....	8
7.	35883 T	Cylinder Cover .....	1
8.	35883 S	Gasket .....	1
9.	667 D-16	Dowel Pin, straight .....	1
10.	22596	Screw .....	1
11.	36284	Gasket .....	1
12.	36229 A1	Eccentric Stud, for Styles 35800DWW, 35800DWWL .....	1
13.	36249 A	Looper Shaft Bushing, front .....	1
14.	35884 D	Gasket .....	1
15.	36284 C	Cylinder Cover and Oil Gauge, front .....	1
16.	J 87 J	Screw .....	4
17.	22560 A	Screw .....	1
18.	36286 A	Gasket .....	1
19.	36286	Cylinder Side Cover .....	1
20.	22766	Screw .....	4
21.	22539 S	Plug Screw .....	1
22.	531	Screw .....	2
23.	29478 CZ	Differential Feed Control Assembly .....	1
24.	538	Screw .....	1
25.	36237 K	Operating Lever .....	1
26.	652 K-24	Washer, fiber .....	1
27.	36237 J	Spring Washer .....	1
28.	36237 H	Stop Screw Pin .....	2
29.	60078 Z	Nut .....	2
30.	36238	Adjusting Plate .....	1
31.	36238 E	Gasket .....	1
32.	660-220	Oil Seal Ring .....	1
33.	36237 E	Adjusting Lever .....	1
34.	87 A	Screw .....	3
35.	22849 A	Screw .....	1
36.	35856 Y	Looper Thread Eyelet .....	2
37.	36237 F	Bushing, for feed bar eccentric stud .....	1
38.	35850 D	Looper Shaft Bushing, rear .....	1
39.	35883 G	Pin .....	1
40.	22894 W	Screw, for cylinder hinge cover spring support stud .....	1
41.	35883 R	Cylinder Hinged Cover .....	1
42.	22791 E	Screw Pin .....	1
43.	35796 B	Chain Cutter Blade, upper .....	1
44.	22747	Screw .....	2
45.	35796 C	Chain Cutter Blade, lower .....	1
46.	36283 C	Cylinder Hinged Cover Spring Support Stud .....	1
47.	35883 U	Cylinder Cover Spring .....	1
48.	22585 C	Screw .....	1
49.	thru 72. See following page		

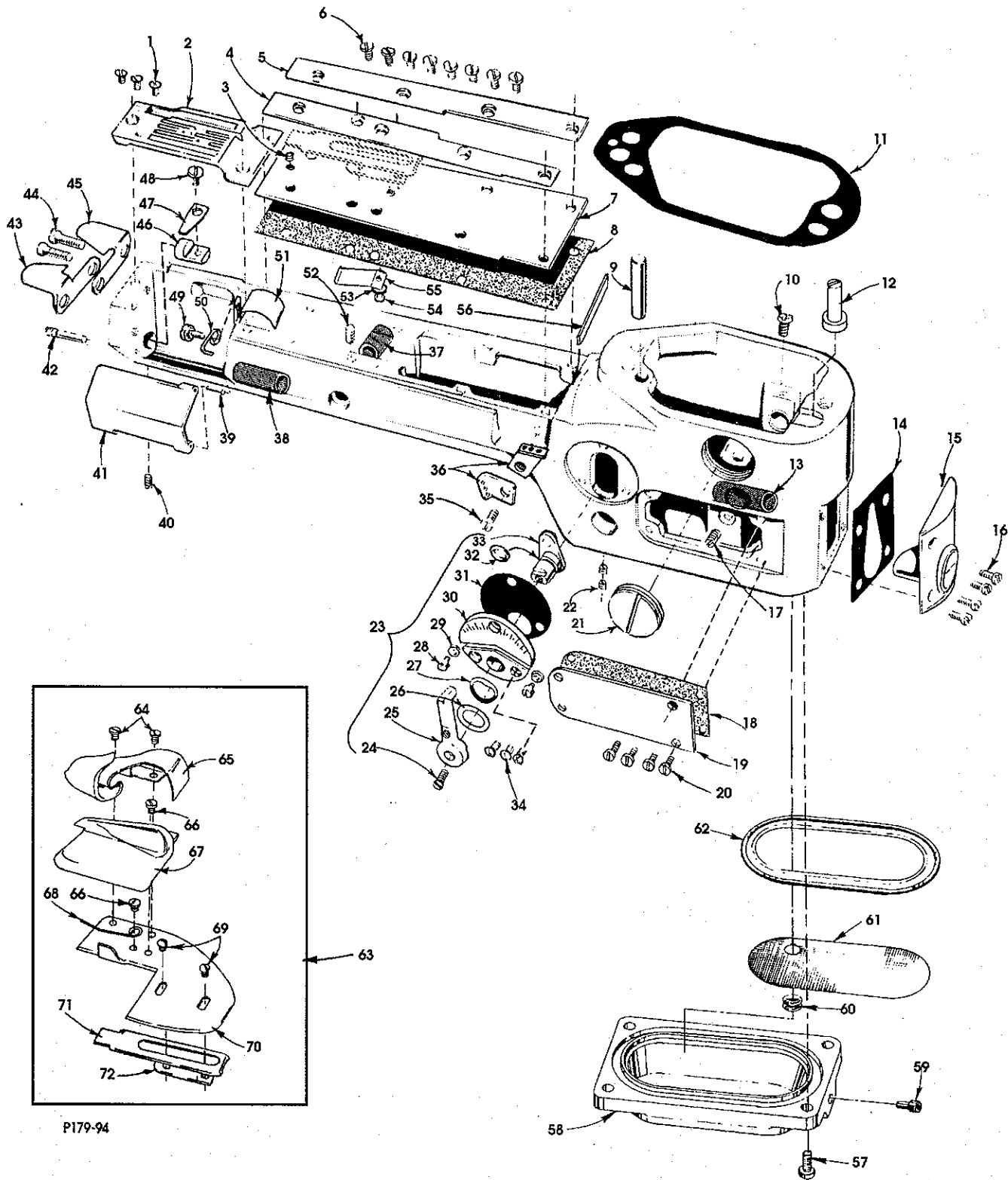

P179-94

DIFFERENTIAL FEED CONTROL, CYLINDER COVERS AND BUSHINGS (CONT.) (ALL GAUGES)

Ref. No.	Part No.	Description	Amt. Req.
1.	thru 48.	See preceding page	
49.	22849	Screw .....	1
50.	36256 B	Cylinder Looper Thread Guide Wire .....	1
51.	35884 M	Lower Lint Shield .....	1
52.	531	Screw .....	1
53.	40-107	Washer .....	1
54.	22798	Screw .....	1
55.	36284 E	Upper Lint Shield .....	1
56.	35883 V	Gasket .....	1
57.	22596	Screw .....	4
58.	36282	Bottom Cover .....	1
59.	22571 E	Screw .....	1
60.	661-150	"O" Ring .....	1
61.	36293 G	Screen .....	1
62.	36284 F	Gasket .....	1
63.	23420 CC 18-1/8	Folder Assembly, for Styles 35800DWW, 35800DLW .....	1
64.	22513	Screw .....	2
65.	23421 CC 18-1/8	Upper Scroll and Base .....	1
66.	22760 A	Screw .....	2
67.	23422 CC 18-1/8	Lower Scroll .....	1
68.	23245	Spring .....	1
69.	22849 A	Screw .....	2
70.	642-423 BLK	Base .....	1
71.	23423 V	Sliding Base .....	1
72.	23423 W	Clamp, for sliding base .....	1

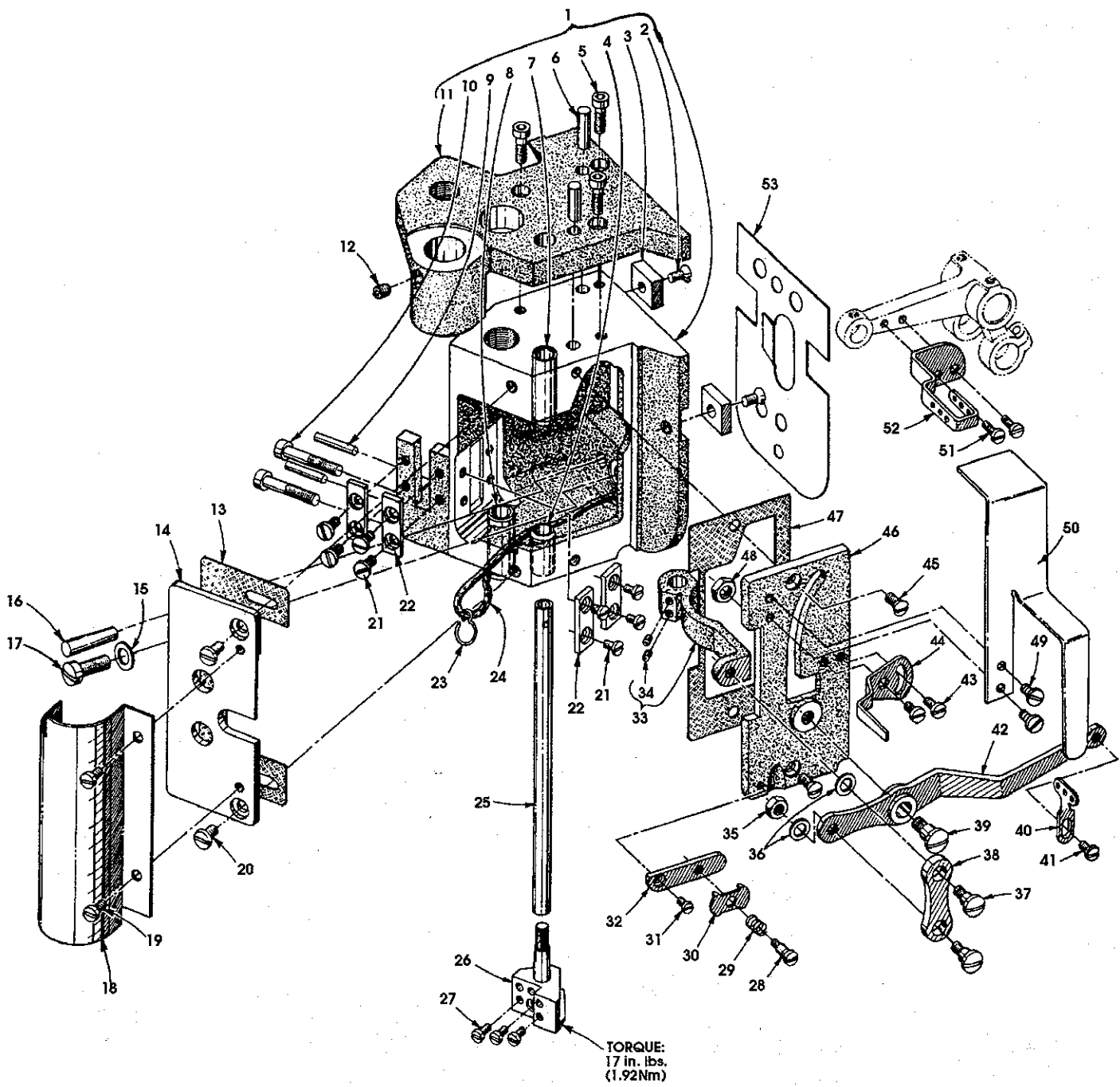

P178-94



## NEEDLE BAR, NEEDLE HEAD, DETACHABLE HEAD AND MISCELLANEOUS COVERS

Ref. No.	Part No.	Description	Amt. Req.
1.	35829 AC	Detachable Head .....	1
2.	22524	Screw .....	2
3.	35767	Sewing Head Key .....	2
4.	35859 L	Needle Bar Bushing, lower .....	1
5.	22653 B-8	Screw .....	3
6.	667 C-12	Dowel Pin .....	2
7.	35859 K	Needle Bar Bushing, upper .....	1
8.	35831 G	Presser Bar Bushing, lower .....	1
9.	667 B-20	Dowel Pin .....	2
10.	22653 B-16	Screw .....	2
11.	35876 AA	Puller Clutch Bracket .....	1
12.	22894 C	Screw .....	1
13.	35889 AA	Gasket .....	1
14.	35889 Y	Head Cover, left .....	1
15.	6042 A	Washer .....	1
16.	664 F-16	Dowel Pin, tapered .....	1
17.	318	Screw .....	1
18.	35889 Z	Detachable Head Cover, front .....	1
19.	22564 B	Screw .....	2
20.	22829	Screw .....	2
21.	22513	Screw .....	8
22.	35731 A	Presser Bar Guide Plate .....	4
23.	35897 AW	Oil Wicking Hook .....	1
24.	CL 21	Oil Wick .....	1
25.	35817 E	Needle Bar, marked "DY" .....	1
26.	35818 BY-8	Needle Bar Head, marked "V-8", for all 8 gauge Styles .....	1
-	35818 BY-9	Needle Bar Head, marked "V-9", for all 9 gauge Styles .....	1
27.	605	Screw .....	3
28.	57 WD	Screw .....	1
29.	15438 C	Needle Thread Nipper Spring .....	1
30.	57 WB	Needle Thread Nipper Spring Plate .....	1
31.	605	Screw .....	1
32.	43296	Needle Thread Nipper Base .....	1
33.	35869 L	Thread Controller Arm .....	1
34.	89	Screw .....	2
35.	12934 A	Nut .....	1
36.	69 H	Washer .....	2
37.	22758 E	Screw .....	2
38.	35869 D	Control Lever Connection Link .....	1
39.	22557 A	Screw .....	1
40.	35869 K	Needle Thread Lever Control Eyelet .....	1
41.	25 B	Screw .....	1
42.	35869 C	Needle Thread Control Lever .....	1
43.	22768	Screw .....	2
44.	35870	Needle Thread Take-up .....	1
45.	22524	Screw .....	2
46.	35889 X	Detachable Head Cover, front .....	1
47.	35889 B	Gasket .....	1
48.	12982	Nut .....	1
49.	22768	Screw .....	2
50.	35854	Needle Bar Guard .....	1
51.	77	Screw .....	2
52.	35864 F	Needle Lever Thread Eyelet .....	1
53.	35889 G	Baffle Plate .....	1

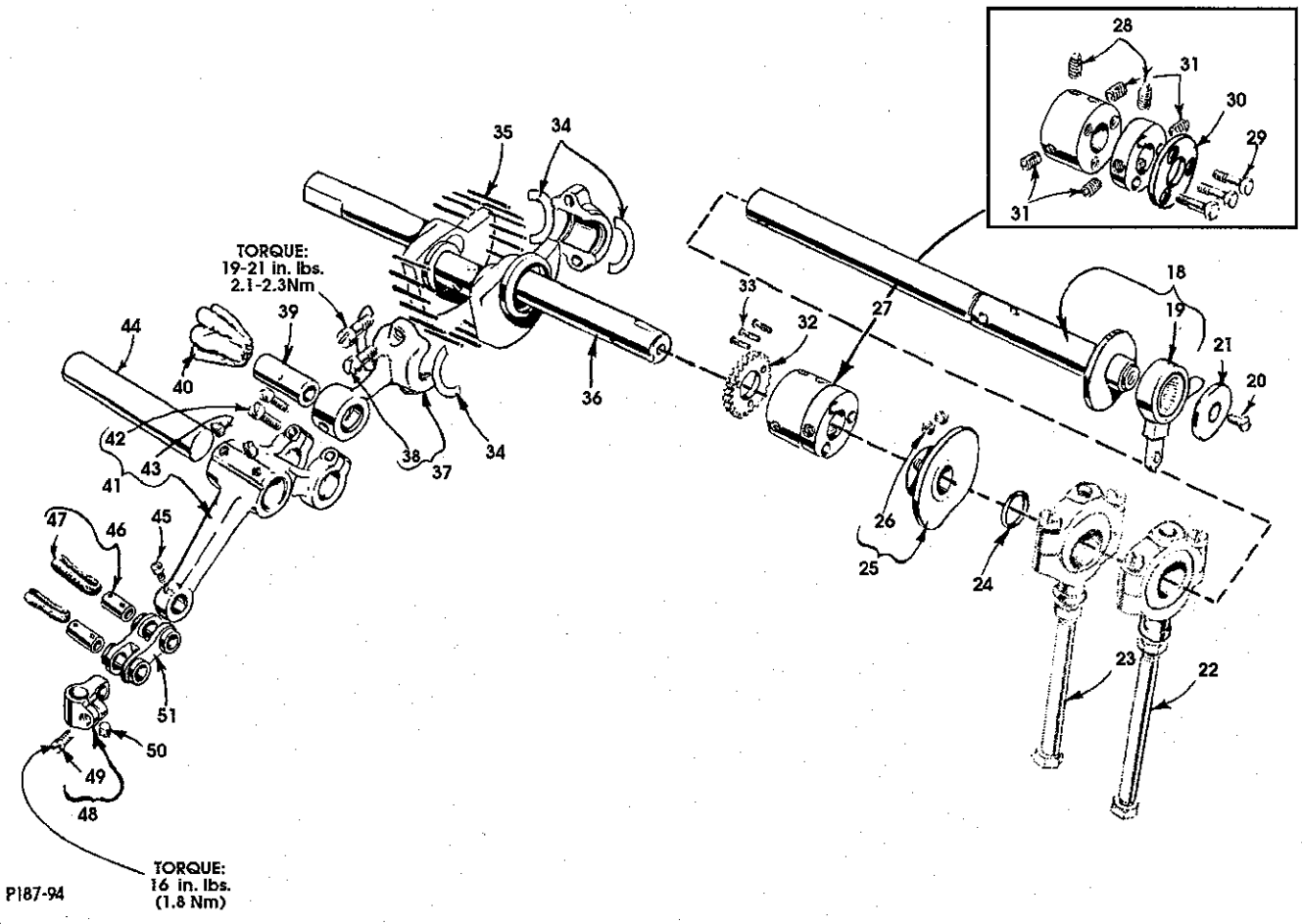
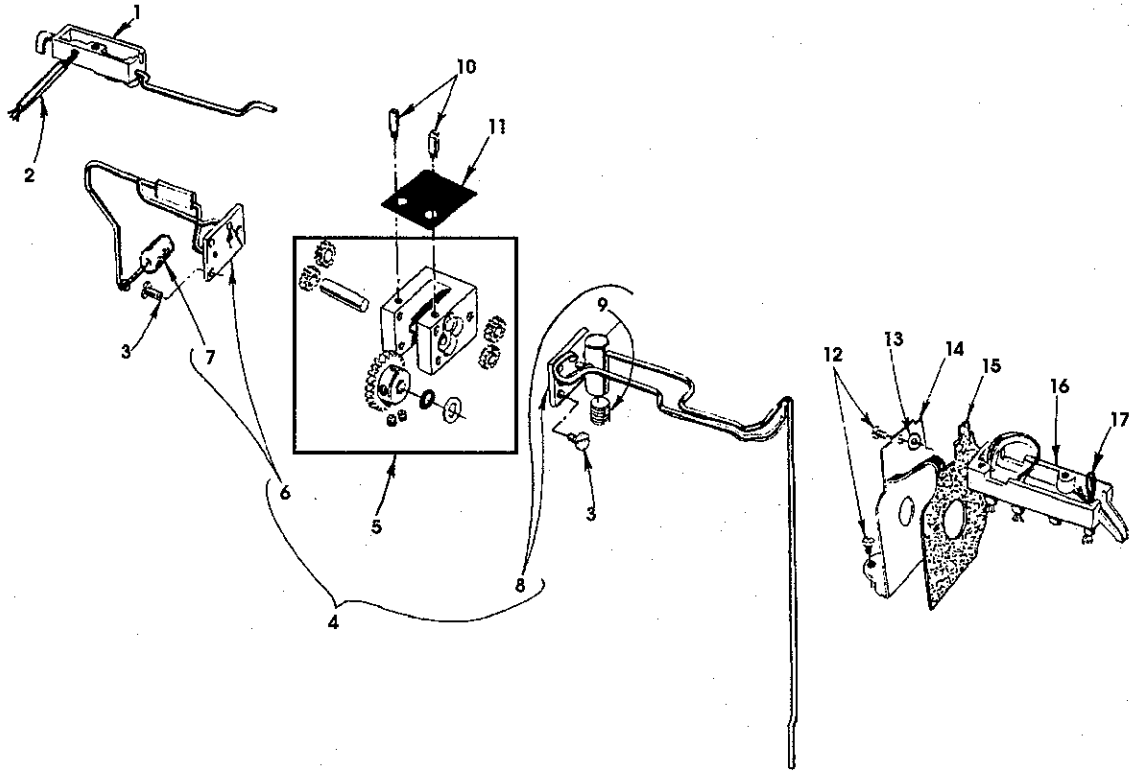

P187-94

**MISCELLANEOUS OILING, NEEDLE LEVER, CRANKSHAFT AND MAIN SHAFT PARTS  
(ALL GAUGES)**

Ref. No.	Part No.	Description	Amt. Req.
1.	35894 V	Oil Reservoir, back .....	1
2.	35897 BU	Oil Reservoir Outlet Tube .....	1
3.	22585 A	Screw .....	6
4.	29472 AD	Oil Pump Assembly .....	1
5.	29472 AC	Oil Pump .....	1
6.	35897 CC	Oil Pump Assembly Cover, rear, for oil pump assembly .....	1
7.	35897 BV	Intake Filter .....	1
8.	35897 CH	Oil Pump Housing Cover, front .....	1
9.	22571 B	Plug Srew .....	1
10.	21756 G	Vent Screw, for oil pump .....	2
11.	35897 BW	Gasket .....	1
12.	90	Screw .....	2
13.	80265	Spacer Washer .....	1
14.	36261 B	Take-up Shield .....	1
15.	35861 D	Gasket .....	1
16.	35894 K	Oil Reservoir, front .....	1
17.	WO 3	Oil Wick .....	1
18.	29478 DZ	Looper Drive Connecting Rod Assembly (see page 25, ref. no.43) .....	1
19.	35853 AJ	Looper Drive Connection .....	1
20.	22526	Screw .....	1
21.	35895 V	Washer .....	1
22.	29478 EC	Feed Drive Eccentric Assembly .....	1
23.	29478 DV	Feed Lift Eccentric Assembly, for Style 35800DLW (see page 21, ref. no. 13) .....	1
-	29478 EB	Feed Lift Eccentric Assembly, for Styles 35800DWW, 35800DWWL (see page 21, ref. no. 13).....	1
24.	660-202	Oil Seal Ring.....	1
25.	35723 C	Looper Thread Take-Up .....	1
26.	22580 D	Screw .....	2
27.	35895 W	Main Shaft and Crankshaft Coupling .....	1
28.	22894 K	Spot Screw .....	2
29.	22519 F	Screw .....	3
30.	35895 Z	Washer Plate .....	1
31.	22894 J	Set Screw .....	4
32.	35897 BY	Oil Pump Driving Gear .....	1
33.	22797	Screw .....	3
34.	35763 G	Needle Bearing Retainer .....	4
35.	35763 F	Needle Bearing .....	28
36.	35822 W	Crankshaft .....	1
37.	35862	Needle Lever Connecting Rod .....	1
38.	22587 B	Screw .....	2
39.	35763	Needle Lever Connecting Rod Pin .....	1
40.	WO 3	Oil Wick .....	1
41.	35815 A	Needle Lever .....	1
42.	22729	Screw .....	2
43.	22596 B	Screw .....	2
44.	35761	Needle Lever Shaft .....	1
45.	77	Screw .....	1
46.	51054	Link Pin .....	2
47.	666-149	Oil Wick .....	2
48.	51254 J	Needle Bar Connection .....	1
49.	22562 A	Screw .....	1
50.	22564	Screw .....	1
51.	56354 A	Needle Lever Link .....	1

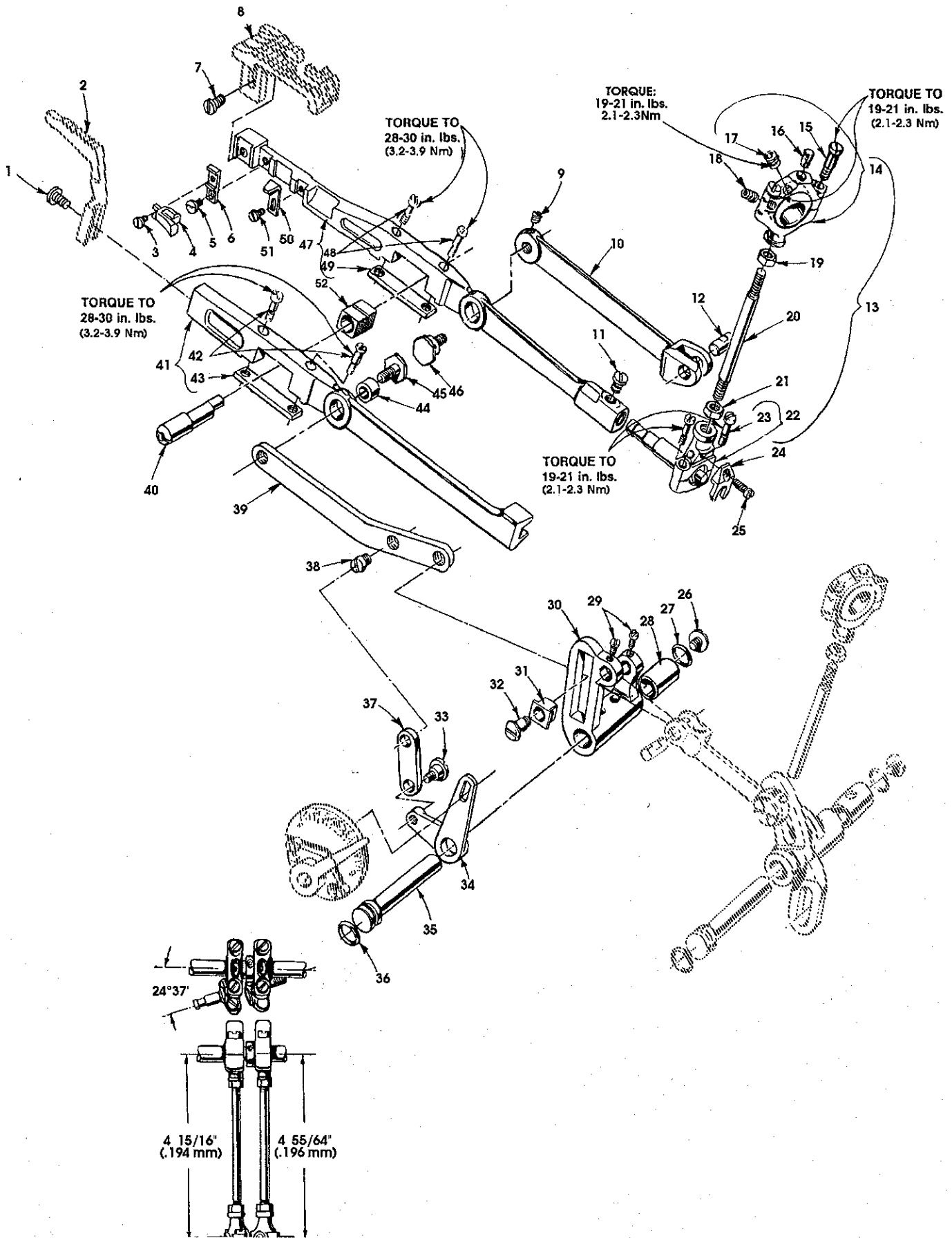

**DIFFERENTIAL FEED BAR, MAIN FEED BAR, FEED LIFT ECCENTRIC ASSEMBLY  
(ALL GAUGES)**

Ref. No.	Part No.	Description	Amt. Req.
1.	22528	Screw .....	1
2.	-----	Differential Feed Dog (see page 35) .....	1
3.	87 U	Screw .....	1
4.	35825 AC	Needle Guard .....	1
5.	22768	Screw .....	1
6.	35835 B	Needle Guard Holder .....	1
7.	22528	Screw .....	1
8.	-----	Main Feed Dog (see page 35) .....	1
9.	22894 P	Screw .....	1
10.	35834 W	Main Feed Bar Driving Link .....	1
11.	33174 B	Screw .....	1
12.	62238 A	Link Pin .....	1
13.	29478 EB	Feed Lift Eccentric Assembly, for Styles 35800DWW, 35800DWWL .....	1
-	29478 DV	Feed Lift Eccentric Assembly, for Style 35800DLW .....	1
14.	29103 U	Feed Lift Eccentric Assembly Ball Joint, for Styles 35800DWW, 35800DWWL .....	1
-	29103 T	Feed Lift Eccentric Assembly Ball Joint, for Style 35800DLW .....	1
15.	22587 E	Screw .....	2
16.	WO 3	Oil Wick .....	1
17.	22894 W	Set Screw .....	2
18.	22894 AA	Spot Screw .....	1
19.	269	Nut, left thread .....	1
20.	36244	Connecting Rod .....	1
21.	18	Nut, right thread .....	1
22.	36244 A	Ball Joint, complete .....	1
23.	22729 C	Screw .....	2
24.	41255 B	Ball Fork .....	1
25.	22747	Screw .....	1
26.	22711	Screw .....	1
27.	660-206	Oil Seal Ring .....	1
28.	36236 B	Bushing, for feed rocker shaft .....	1
29.	77	Screw .....	2
30.	35836 A	Feed Rocker .....	1
31.	36236 K	Differential Feed Driving Link Slide Block .....	1
32.	36236 J	Differential Feed Bar Driving Link Stud .....	1
33.	22504 C	Screw .....	1
34.	36237	Differential Feed Adjusting Lever .....	1
35.	36236 A	Feed Rocker Shaft .....	1
36.	660-207	Oil Seal Ring .....	1
37.	36237 A	Differential Feed Adjusting Lever Link .....	1
38.	22845 M	Screw .....	1
39.	35836 B	Differential Feed Bar Driving Link .....	1
40.	36234 D	Feed Bar Eccentric Stud .....	1
41.	36234 F	Differential Feed Bar .....	1
42.	22587 H	Screw .....	2
43.	36234 G	Feed Bar Plate .....	1
44.	36236 H	Bushing .....	1
45.	36236 G	Differential Feed Bar Driving Link Stud .....	1
46.	35834 X	Main Feed Bar Eccentric Driving Stud .....	1
47.	35834 AB	Main Feed Bar .....	1
48.	22587 H	Screw .....	2
49.	36234 G	Feed Bar Plate .....	1
50.	35834 AC	Main Feed Dog Support, for Styles 35800DWW, 35800DWWL .....	1
-	35834 AA	Main Feed Dog Support, for Style 35800DLW .....	1
51.	22804	Screw .....	1
52.	36234 C	Feed Bar Slide Block .....	1

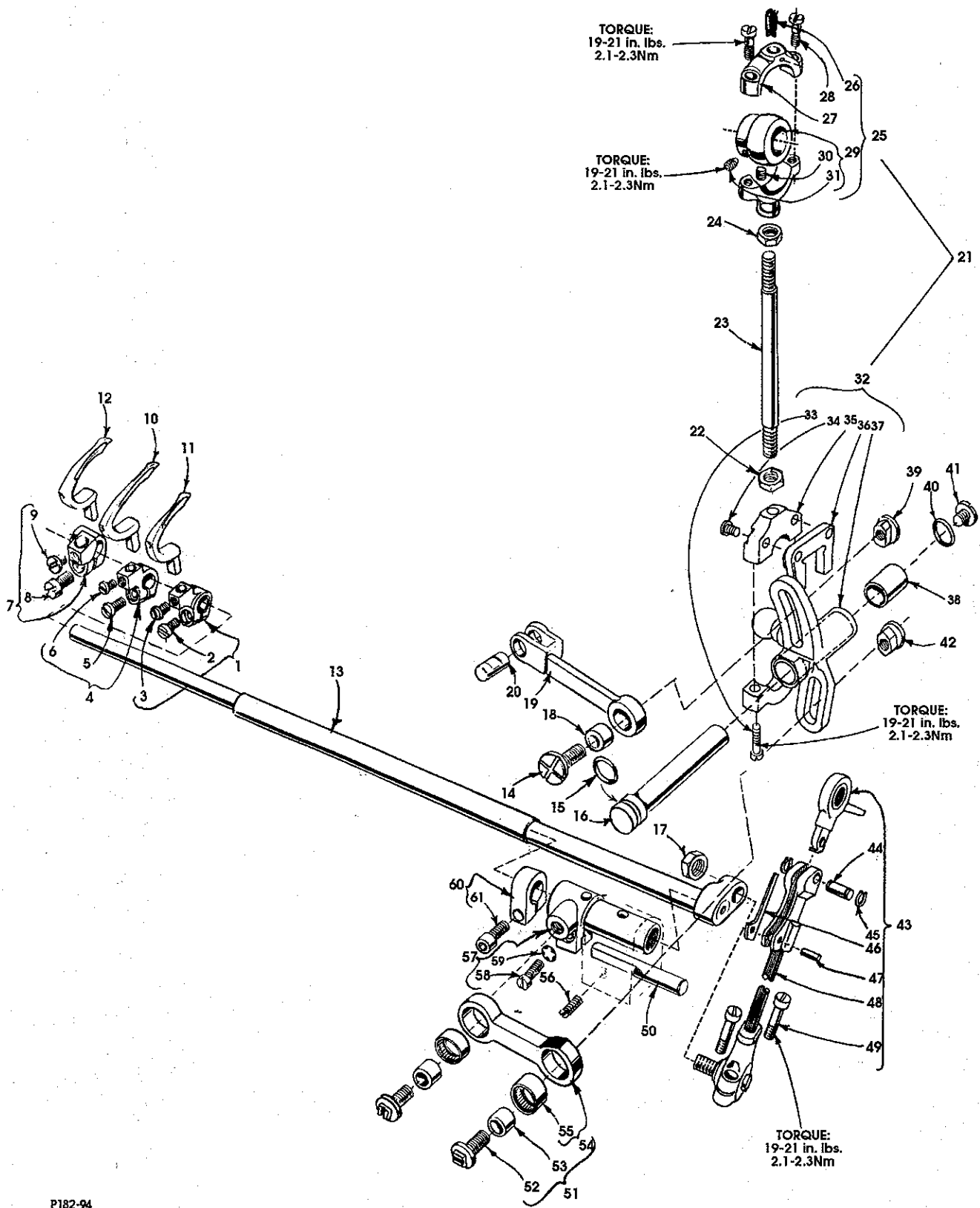

P182-94

**LOOPERS, LOOPER HOLDERS, FEED DRIVE ASSEMBLY AND LOOPER AVOID ASSEMBLY**

Ref. No.	Part No.	Description	Amt. Req.
1.	35848 B	Looper Holder, for left needle looper, marked "A" .....	1
2.	22562 A	Screw .....	1
3.	22564	Screw .....	1
4.	35848 E	Looper Holder, for right needle looper, marked "D" .....	1
5.	22562 A	Screw .....	1
6.	22564	Screw .....	1
7.	35848 D	Looper Holder, for middle needle looper, marked "C" .....	1
8.	22562 A	Screw .....	1
9.	22564	Screw .....	1
10.	35809 AY	Looper, for middle needle, marked "AV" .....	1
11.	35808 AY	Looper, for right needle, marked "AU" .....	1
12.	35809 BY	Looper, for left needle, marked "AY" .....	1
13.	35849 C	Looper Rocker Shaft .....	1
14.	35836 C	Feed Rocker Driving Link Screw .....	1
15.	660-207	Oil Seal Ring .....	1
16.	36236 A	Feed Drive Shaft .....	1
17.	258 A	Nut .....	1
18.	36236 H	Bushing, for feed rocker driving link .....	1
19.	36236 C	Feed Rocker Driving Link .....	1
20.	62238 A	Link Pin .....	1
21.	29478 EC	Feed Drive Assembly .....	1
22.	18	Nut, right hand thread .....	1
23.	43246	Connecting Rod .....	1
24.	269	Nut, left hand thread .....	1
25.	29101 K	Feed Drive Eccentric Assembly .....	1
26.	WO 3	Oil Wick .....	1
27.	35840	Eccentric Bearing .....	1
28.	22587 E	Screw .....	2
29.	35839 C	Eccentric .....	1
30.	22894 U	Screw .....	1
31.	22894 W	Screw .....	2
32.	35842 L	Feed Drive Rocker Assembly .....	1
33.	22729 C	Screw .....	2
34.	22747	Screw .....	2
35.	35840 A	Shell .....	1
36.	35846 D	Guide .....	1
37.	35842 K	Feed Drive Looper Avoid Assembly .....	1
38.	36236 B	Bushing .....	1
39.	35866	Nut .....	1
40.	thru 61. See following page		

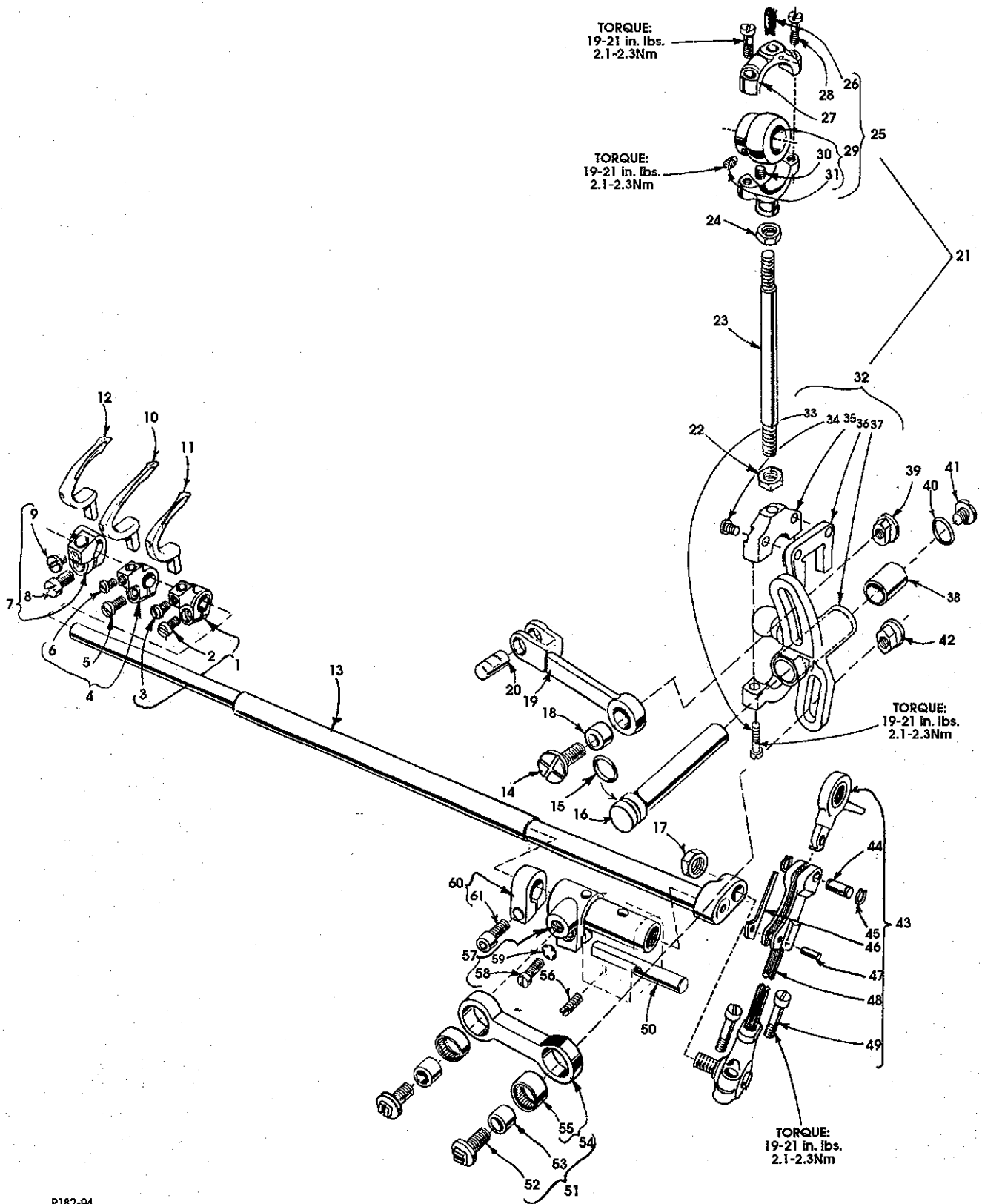

P182-94



LOOPERS, LOOPER HOLDERS, FEED DRIVE ASSEMBLY AND LOOPER AVOID ASSEMBLY (CONT.)

Ref. No.	Part No.	Description	Amt. Req.
	1. thru 39. See preceding page		
40.	660-206	Oil Seal Ring .....	1
41.	22711	Screw .....	1
42.	35766 B	Nut .....	1
43.	29478 DZ	Looper Drive Connecting Rod Assembly .....	1
44.	35853 V-156	Hinge Pin .....	1
45.	660-310	Truarc Ring .....	2
46.	56341 G	Locking Spring .....	1
47.	50-458 BLK	Pin .....	1
48.	35853 AK	Looper Drive Connecting Rod .....	1
49.	22729 D	Screw .....	2
50.	36278 C	Stud, for looper shaft sleeve .....	1
51.	29478 DM	Looper Avoid Link Assembly .....	1
52.	35851 K	Screw .....	2
53.	P 51-184 BLK	Ferrule .....	2
54.	35851 M	Connecting Rod Bearing Shell .....	1
55.	660-311	Needle Bearing .....	2
56.	22560 A	Screw .....	1
57.	36249 B	Looper Shaft Sleeve .....	1
58.	22729 D	Screw .....	1
59.	652 C-9	Washer .....	1
60.	35751 G	Looper Shaft Collar .....	1
61.	22572 B	Screw .....	1

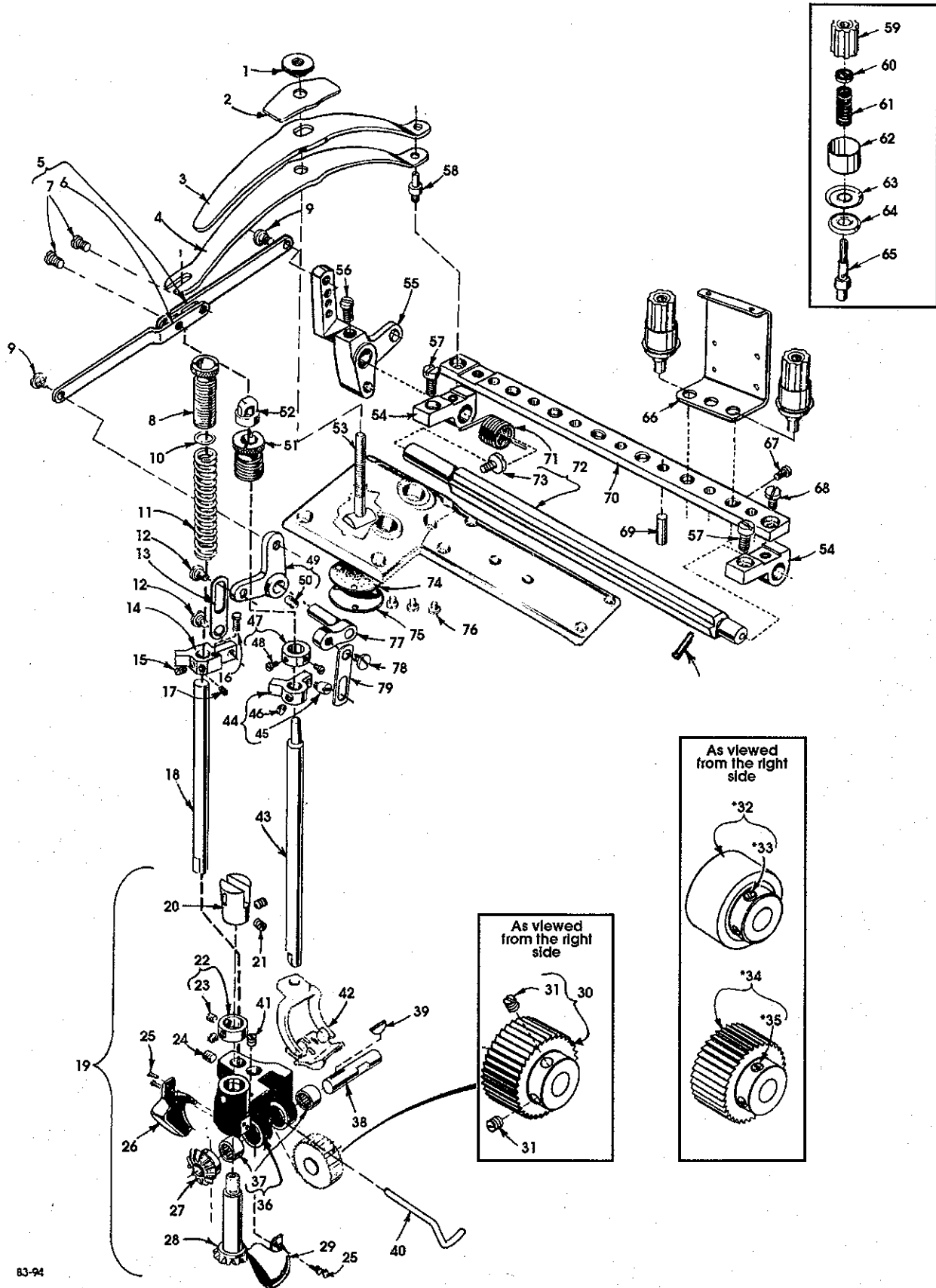

83-94

## UPPER ROLLER FEED, FOOT LIFTER AND THREAD TENSION PARTS

Ref. No.	Part No.	Description	Amt. Req.
1.	35733 B	Presser Regulating Screw .....	1
2.	35833 C	Presser Spring Plate .....	1
3.	35833 E	Presser Spring, upper .....	1
4.	35833 D	Presser Spring, lower .....	1
5.	36280 V	Lifter Lever Link Assembly .....	1
6.	36280 U	Lifter Lever Link .....	1
7.	22585 C	Screw .....	2
8.	61257 G	Roller Presser Spring Regulator .....	1
9.	86	Screw .....	2
10.	61256 G	Roller Presser Spring Washer .....	1
11.	35873 Z	Roller Presser Spring .....	1
12.	22758 C	Screw .....	2
13.	35880 K	Lifter Lever Bell Crank Link .....	1
14.	35873 AH	Presser Bar Connection .....	1
15.	89	Screw .....	1
16.	22764	Screw .....	1
17.	22764 A	Screw .....	1
18.	35873 W	Roller Presser Bar .....	1
19.	29478 ED	Puller Assembly .....	1
20.	54274 C	Feed Roller Upper Connection .....	1
21.	22894 W	Screw .....	2
22.	14649	Drive Gear Collar .....	1
23.	88	Screw .....	2
24.	22894 C	Screw .....	1
25.	22738	Screw .....	4
26.	35875 AA	Gear Guard, front .....	1
27.	35875 X	Driven Miter Gear .....	1
28.	35875 Y	Drive Miter Gear .....	1
29.	35875 Z	Gear Guard, rear .....	1
30.	35826 X	Feed Roller .....	1
31.	22560 B	Screw .....	2
*32.	35826 DZ	Wide Rubber Roller .....	1
*33.	22560 B	Screw .....	2
*34.	35826 CB	Feed Roller, reverse teeth .....	1
*35.	22560 B	Screw .....	2
36.	35873 AJ	Feed Roller Frame .....	1
37.	660-303	Needle Bearing .....	1
38.	35873 AK	Feed Roller Shaft .....	1
39.	35877 AA	Woodruff Key .....	1
40.	21237 ES	Air Blower Tube .....	1
41.	73 C	Screw .....	1
42.	-----	Presser Foot (see page 35) .....	1
43.	35878 S	Presser Bar .....	1
44.	35831 C	Presser Bar Lifter and Guide .....	1
45.	402	Screw .....	1
46.	22560 B	Screw .....	1

47. thru 79. See following page

\* Items can be purchased as an extra send charge.

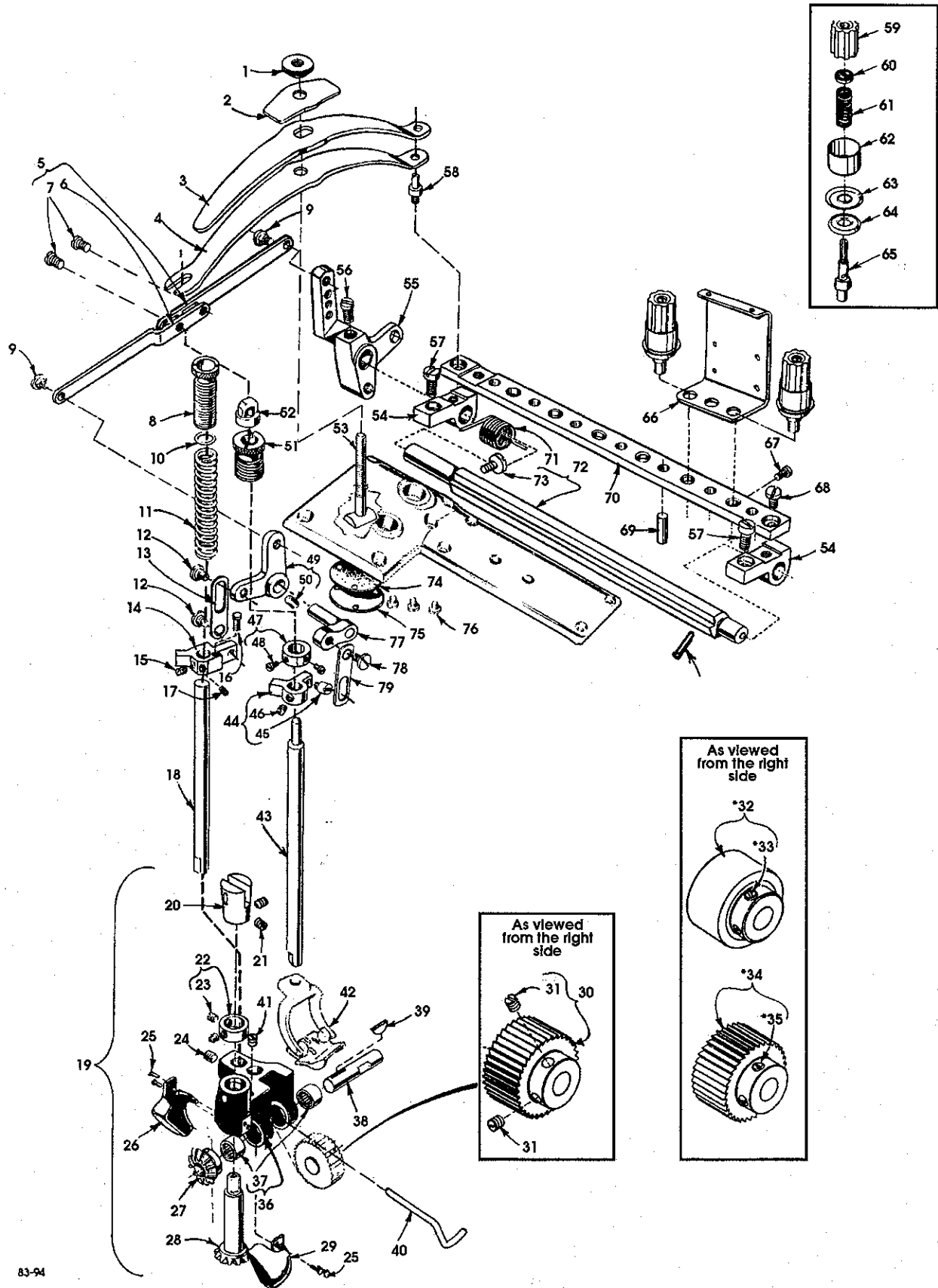

83-94

**UPPER ROLLER FEED, FOOT LIFTER AND THREAD TENSION PARTS (CONT.)**

Ref. No.	Part No.	Description	Amt. Req.
	1. thru 46. See preceding page		
47.	52888 B	Collar .....	1
48.	22562	Screw .....	2
49.	35880 P	Lifter Lever Bell Crank .....	1
50.	22894 J	Screw .....	1
51.	35878 H	Presser Bar Spring and Spring Regulator .....	1
52.	55287 L	Presser Spring Rest .....	1
53.	35878 F	Presser Spring Regulating Screw .....	1
54.	36292 M	Tension Plate Bracket .....	2
55.	36280 W	Lifter Lever .....	1
56.	22839 D	Screw .....	1
57.	136	Screw .....	2
58.	35833 F	Presser Spring Rest .....	1
59.	C 50092 S	Tension Nut .....	6
60.	39592 AK	Tension Post Ferrule .....	6
61.	51292 F-4	Looper Thread Tension Spring, for looper .....	3
-	110-3	Needle Thread Tension Spring, for needle .....	3
62.	56392 F	Shield, tension spring .....	6
63.	35792	Tension Disc, large .....	6
64.	109	Tension Disc, small .....	6
65.	36292 P	Tension Post .....	6
66.	36298 G	Tension Thread Eyelet .....	3
67.	22562 A	Screw .....	6
68.	94	Screw .....	1
69.	35792 T	Tension Disc Release Pin .....	7
70.	36298 F	Tension Support .....	1
71.	36292 K	Tension Release Shaft Spring .....	1
72.	36292 N	Tension Release Shaft .....	1
73.	22784 F	Screw .....	1
-	660-219 S	Roll Pin, (not shown) .....	1
74.	35888 M	Gasket .....	1
75.	35888 L	Cover Plate .....	1
76.	98 A	Screw .....	3
77.	35880 N	Presser Bar Lifter Lever .....	1
78.	22758 C	Screw .....	1
79.	35880 L	Lifter Lever Connecting Link .....	1

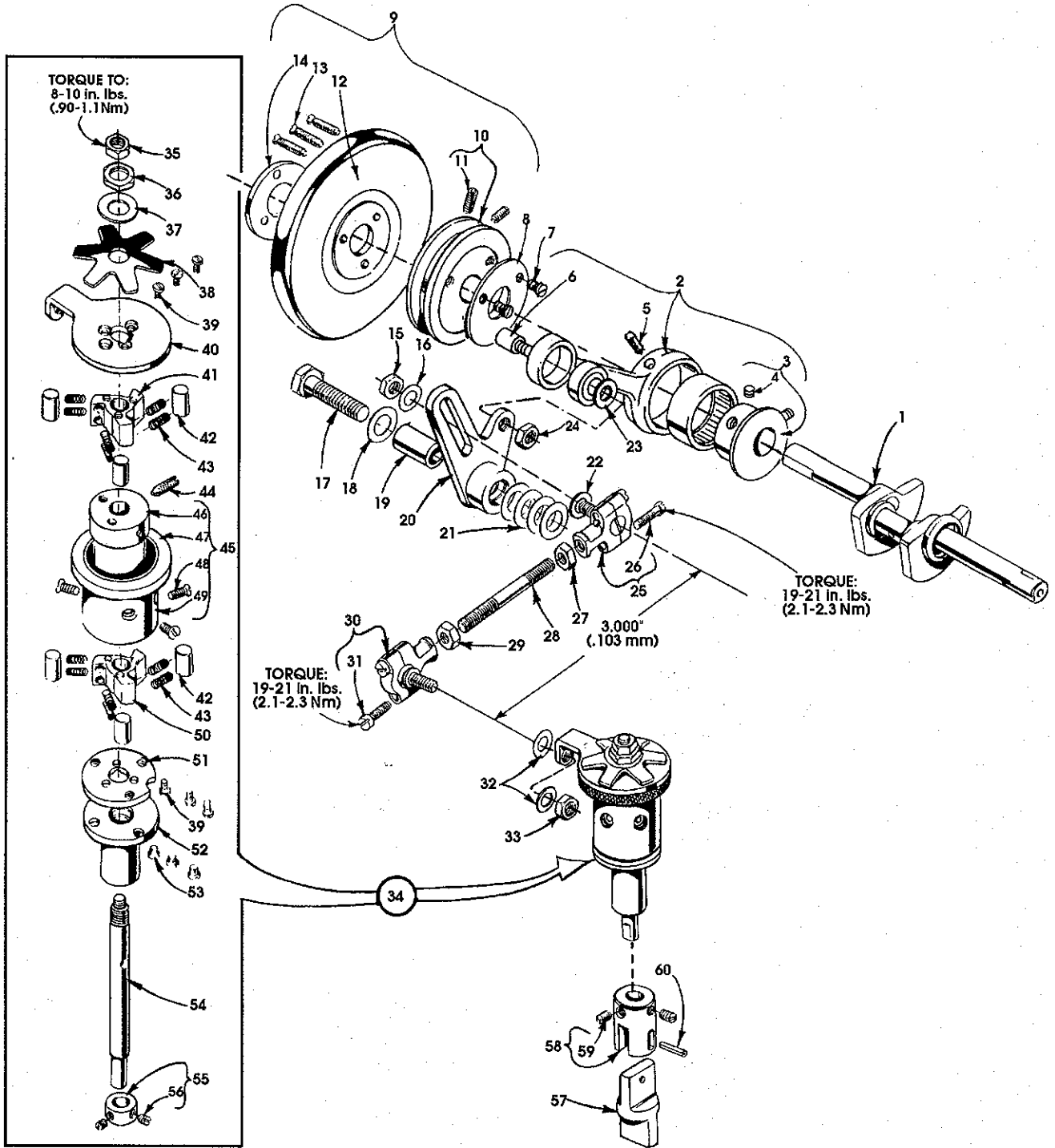

P185-94

## PULLEY, CRANKSHAFT, CLUTCH AND CLUTCH DRIVING MECHANISM

Ref. No.	Part No.	Description	Amt. Req.
1.	35822 W	CrankShaft .....	1
2.	29480 ALY	Connecting Rod and Clutch Driving Eccentric Assembly .....	1
3.	35877 XA	Eccentric .....	1
4.	22894 C	Screw .....	2
5.	666-186	Oil Wick .....	1
6.	50342 V	Shoulder Screw .....	1
7.	22589	Screw .....	3
8.	35821 V	Washer .....	1
9.	35821 S	Pulley Assembly .....	1
10.	35821 F	Pulley .....	1
11.	22894 E	Set Screw .....	2
12.	61321 J	Handwheel .....	1
13.	22574	Screw .....	3
14.	61321 L	Clamp Plate .....	1
15.	258	Nut .....	1
16.	20	Washer .....	1
17.	22644 K-80	Screw .....	1
18.	61351 C	Washer .....	1
19.	35877 N	Segment Lever Bushing .....	1
20.	35877 Z	Clutch Driving Segment Lever .....	1
21.	61351 C	Washer .....	4
22.	36 G	Washer .....	1
23.	6042 A	Washer .....	1
24.	258	Nut .....	1
25.	35876 V	Ball Joint Assembly, right .....	1
26.	22729 C	Screw .....	2
27.	269	Nut, left hand thread .....	1
28.	4761	Roller Clutch Connecting Rod .....	1
29.	18	Nut, right hand thread .....	1
30.	22894 W	Roller Clutch Ball Joint Assembly, left .....	2
31.	22729 C	Screw .....	2
32.	20	Washer .....	2
33.	18	Nut .....	1
34. thru 60. See following page			

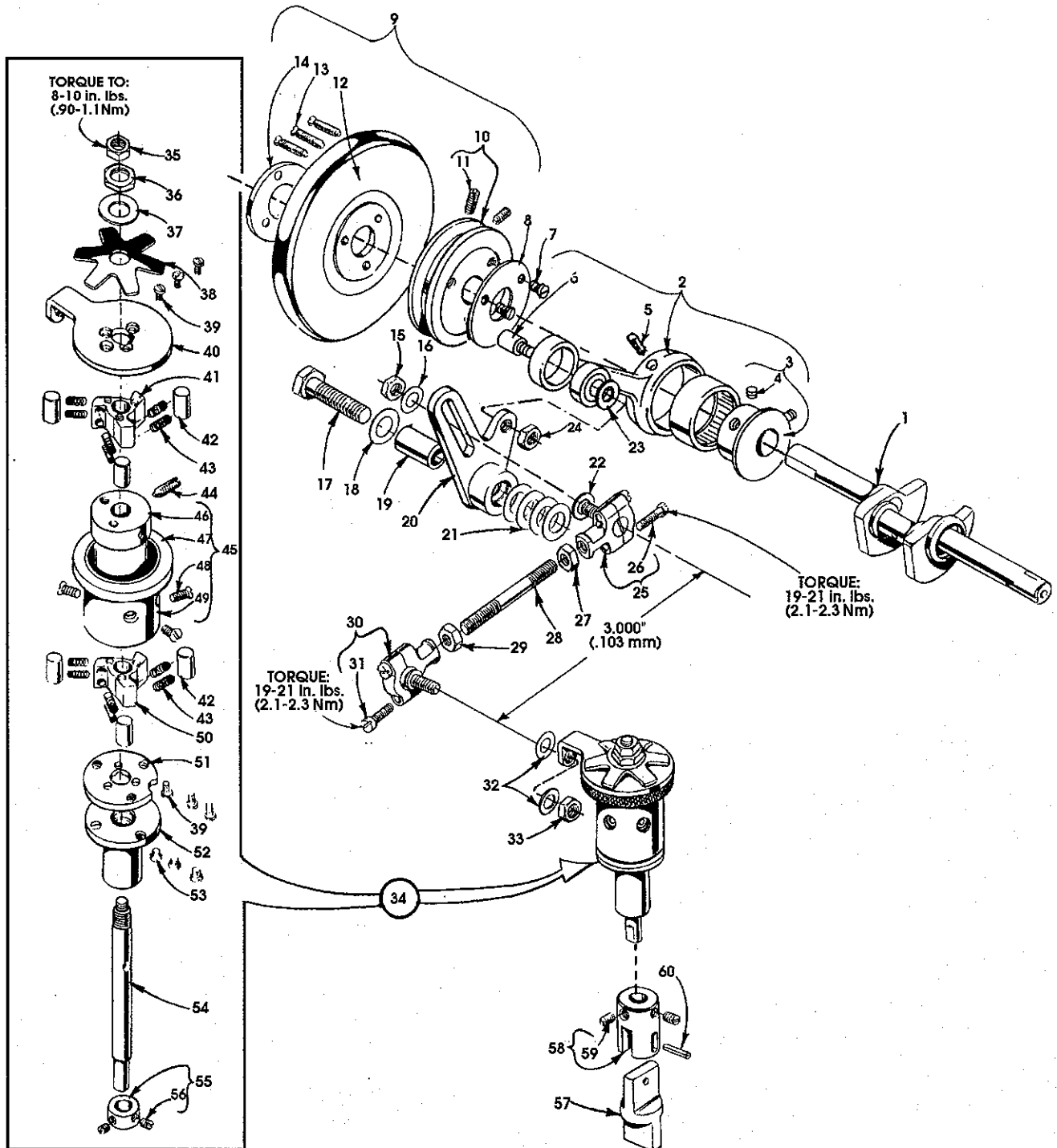

P185-94



**PULLEY, CRANK SHAFT, CLUTCH AND CLUTCH DRIVING MECHANISM (CONT.)**

Ref. No.	Part No.	Description	Amt. Req.
1. thru 33. See preceding page			
34.	29478 BY	Constant Wedge Angle Clutch Assembly .....	1
35.	18	Nut .....	1
36.	11638 M	Nut .....	1
37.	61351 C	Washer .....	1
38.	54274 N	Brake Spring .....	1
39.	605 A	Screw .....	6
40.	35876 AC	Clutch Drive Lever .....	1
41.	54274 H	Clutch Disc, upper .....	1
42.	54274 L	Clutch Roller .....	6
43.	54274 Y	Clutch Roller Spring and Wear Cap .....	12
44.	22894 H	Spot Screw .....	1
45.	35876 AB	Barrel Assembly .....	1
46.	50-835 BLK	Barrel Core .....	1
47.	35876 AD	Drive Lever Brake .....	1
48.	538	Screw .....	3
49.	50-834 BLK	Barrel .....	1
50.	54274 H	Clutch Disc, lower .....	1
51.	35876 AG	Locking Spacer Plate .....	1
52.	35876 AF	Lower Bearing .....	1
53.	22564	Screw .....	3
54.	35876 AE	Feed Drive Shaft .....	1
55.	41363 U	Collar .....	1
56.	22743	Screw .....	2
57.	54279	Feed Roller Drive Floating Connection .....	1
58.	35876 AH	Feed Roller Connection, upper .....	1
59.	22560 B	Screw .....	2
60.	660-219	Roll Pin .....	1

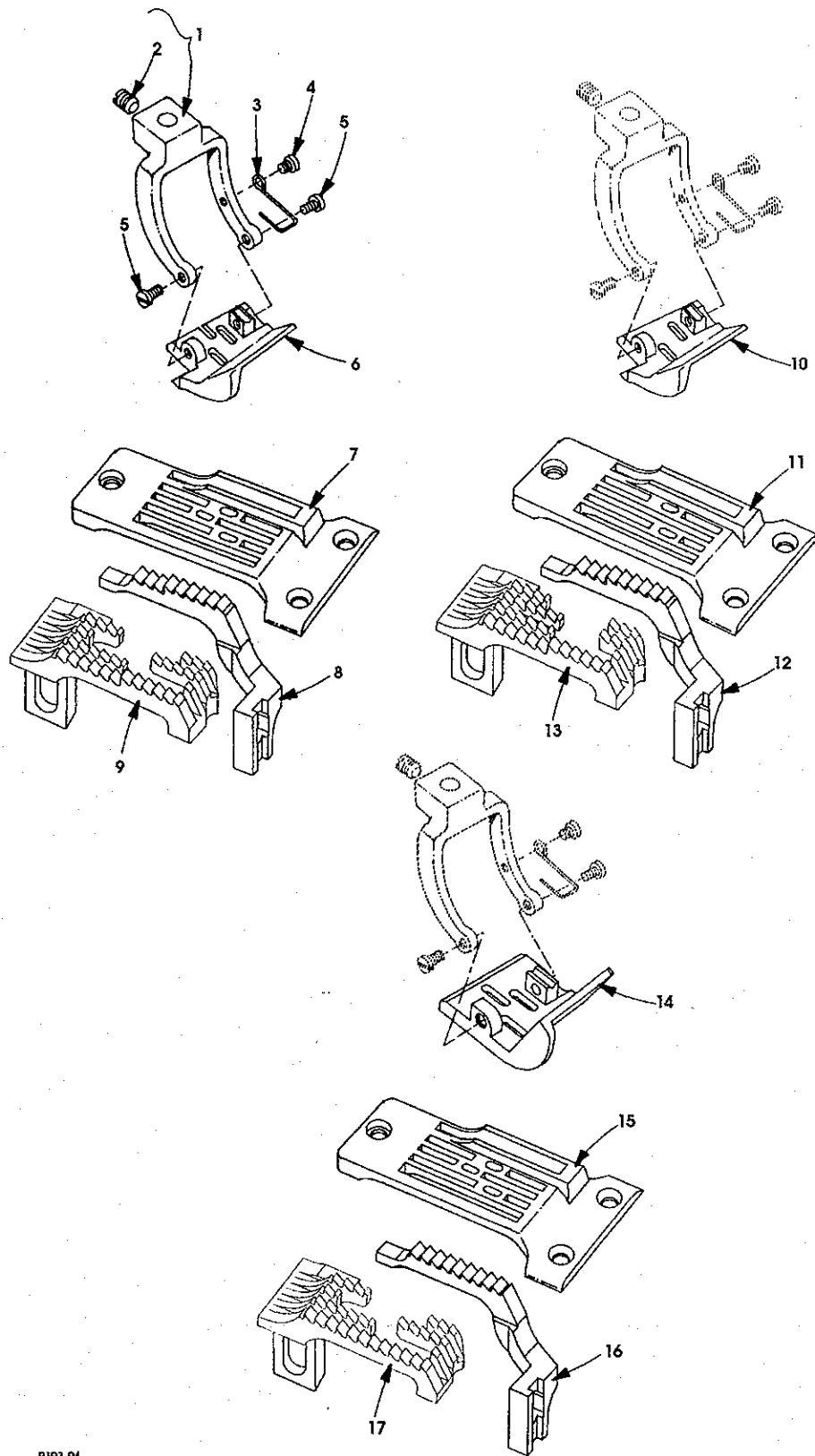

P193-94

**PRESSER FOOT, THROAT PLATE, FEED DOGS**

Ref. No.	Part No.	Description	Amt. Req.
1.	35874 B	Presser Foot Fork .....	1
2.	22894 C	Screw .....	1
3.	35830 K	Spring .....	1
4.	22599	Screw .....	1
5.	22845 A	Screw .....	2
6.	35830 DWW8	Presser Foot, for Styles 35800DWW8, DWWL8 .....	1
-	35830 DWW9	Presser Foot, for Styles 35800DWW9, DWWL9 .....	1
7.	35824 DX8	Throat Plate, for Styles 35800DWW8, DWWL8 .....	1
-	35824 DX9	Throat Plate, for Styles 35800DWW9, DWWL9 .....	1
8.	35826 DX	Differential Feed Dog, for Styles 35800DWW8, 9, DWWL 8, 9 .....	1
9.	35805 DX	Main Feed Dog, for Styles 35800DWW8, 9, DWWL8, 9 .....	1
10.	35830 DWW18	Presser Foot, for Styles 35800DWW18, DWWL18 .....	1
11.	35824 DW18	Throat Plate, for Styles 35800DWW18, DWWL18 .....	1
12.	35826 DX	Differential Feed Dog, for Styles 35800DWW18, DWWL18 .....	1
13.	35805 DW18	Main Feed Dog, for Styles 35800DWW18, DWWL18 .....	1
14.	35820 BQW9	Presser Foot, for Style 35800DLW9 .....	1
15.	35824 BQW9	Throat Plate, for Style 35800DLW9 .....	1
16.	35826 DLW9	Differential Feed Dog, for Style 35800DLW9 .....	1
17.	35805 DLW	Main Feed Dog, for Style 35800DLW9 .....	1

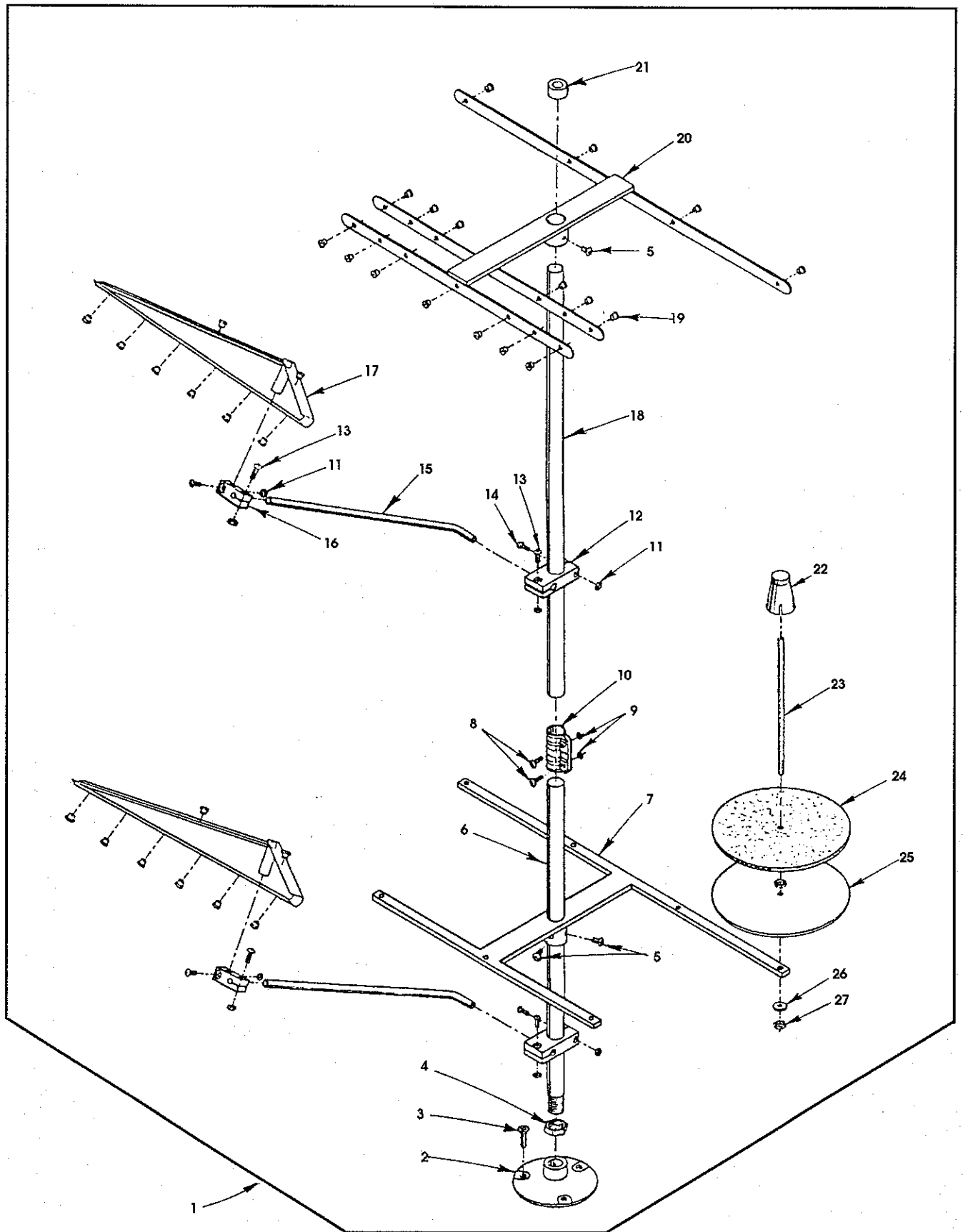

P191-94

## THREAD STAND

Ref. No.	Part No.	Description	Amt. Req.
1.	21101 57	Thread Stand, complete .....	1
2.		Thread Stand Base .....	1
3.		Screw .....	3
4.		Nut .....	1
5.		Screw .....	4
6.		Thread Stand Rod, short .....	1
7.		Base Bracket .....	1
8.		Screw .....	2
9.		Nut .....	2
10.		Joint .....	1
11.		Nut .....	8
12.		Holder, large .....	2
13.		Screw .....	6
14.		Screw, long .....	2
15.		Thread Guide Rod .....	2
16.		Holder, thread guide .....	2
17.		Thread Guide .....	2
18.		Thread Stand Rod, long .....	1
19.		Thread Eyelet .....	34
20.		Thread Guide .....	1
21.		Cap .....	1
22.		Spool Retainer .....	7
23.		Spool Pin .....	7
24.		Felt Disc .....	7
25.		Support Disc .....	7
26.		Spring Washer .....	7
27.		Nut .....	14

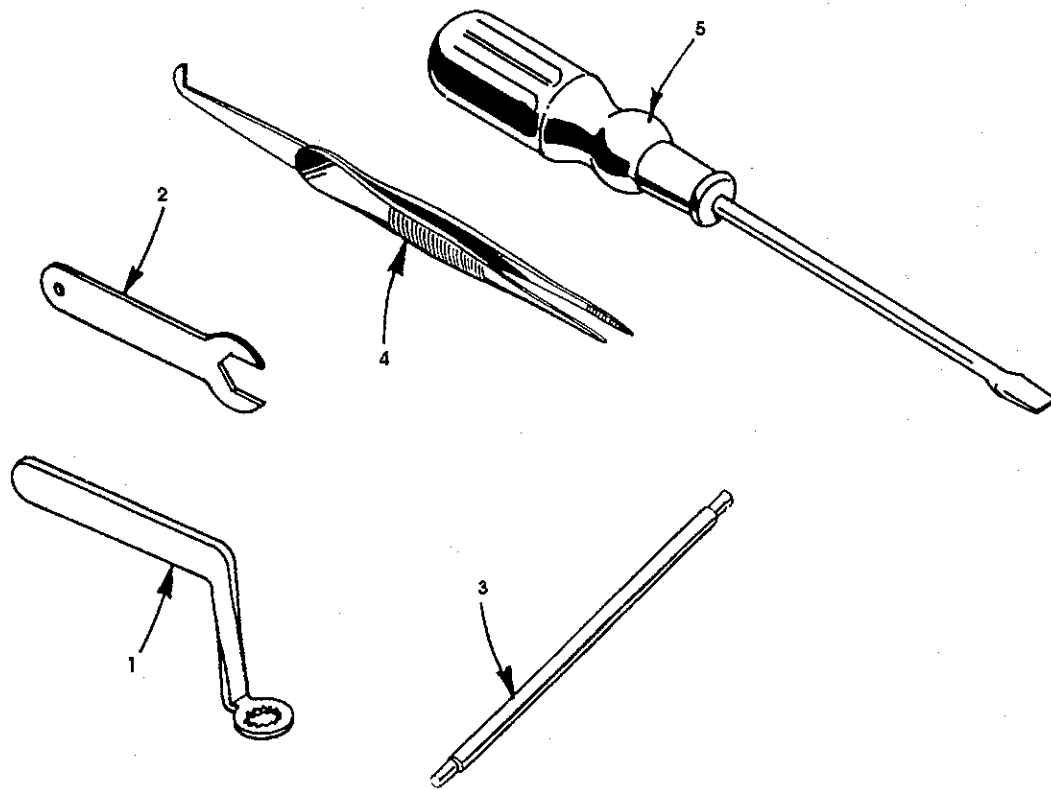

P186-94

### ACCESSORIES

Ref. No.	Part No.	Description	Amf. Req.
1.	TT 85	Wrench, for looper avoid .....	1
2.	21388 AZ	Wrench, for feed bar .....	1
3.	21227 AR	Needle Head Torque Rod .....	1
4.	660-240	Thread Tweezers .....	1
5.	21201	Screwdriver .....	1
-	660-457	Plastic Cover (not shown) .....	1
-	28604 R	Oil Can (not shown) .....	1
-	660-1012	Oil Can Nozzle (not shown) .....	1
-	WR 56	Allen Wrench, size 1/4" (not shown) .....	1
-	WR 58	Allen Wrench, size 3/8" (not shown) .....	1
-	WR 60	Allen Wrench, size 1/2" (not shown) .....	1









## NUMERICAL INDEX OF PARTS

<u>Part No.</u> <u>Page No.</u>	<u>Part No.</u> <u>Page No.</u>	<u>Part No.</u> <u>Page No.</u>	<u>Part No.</u> <u>Page No.</u>
109.....29	22738.....27	35723 C.....19	35835 B.....21
110-3.....29	22743.....33	35731 A.....17	35836 A.....21
11638 M.....33	22747.....13, 21, 23	35733 B.....27	35836 B.....21
12934 A.....9, 17	22758 C.....27, 29	35751 G.....25	35836 C.....23
12982.....17	22758 E.....17	35760 D.....9	35839 C.....23
136.....29	22759 A.....9	35760 E.....9	35840.....23
14649.....27	22760 A.....15	35761.....19	35840 A.....23
15438 C.....17	22764.....27	35761 D.....9	35842 K.....23
18.....21, 23, 31, 33	22764 A.....27	35763.....19	35842 L.....23
18-1426.....9	22766.....13	35763 F.....19	35846 D.....23
20.....31	22768.....17, 21	35763 G.....19	35848 B.....23
21101 S7.....37	22784 F.....29	35766 B.....25	35848 D.....23
21201.....38	22791 E.....13	35767.....17	35848 E.....23
21227 AR.....38	22797.....19	35772 S.....11	35849 C.....23
21237 ES.....27	22798.....13, 15	35772 T.....11	35850 D.....13
21388 AZ.....38	22804.....21	35781 D.....11	35851 K.....25
21756 G.....19	22829.....11, 17	35792.....29	35851 M.....25
22504 C.....21	22839 D.....29	35792 T.....29	35853 AA.....11
22513.....15, 17	22845 A.....35	35796 B.....13	35853 AJ.....19
22516 A.....9	22845 M.....21	35796 C.....13	35853 AK.....25
22519 F.....19	22849.....15	35805 DLW.....35	35853 V-156.....25
22524.....13, 17	22849 A.....13, 15	35805 DW18.....35	35853 W.....11
22526.....19	22894 AA.....21	35805 DX.....35	35853 Y.....11
22528.....21	22894 C.....17, 27, 31, 35	35808 AY.....23	35853 Z.....9
22539 S.....13	22894 E.....31	35809 AY.....23	35854.....17
22539 T.....9	22894 F.....9	35809 BY.....23	35856 AA.....11
22557 A.....17	22894 H.....33	35815 A.....19	35856 Y.....13
22560 A.....13, 25	22894 J.....19, 29	35817 E.....17	35859 K.....17
22560 B.....27, 33	22894 K.....19	35818 BY-8.....17	35859 L.....17
22562.....29	22894 P.....21	35818 BY-9.....17	35861 D.....19
22562 A.....19, 23, 29	22894 U.....23	35820 BQW9.....35	35862.....19
22564.....19, 23, 33	22894 W.....13, 21, 23, 27, 31	35821 F.....31	35864 F.....17
22564 B.....9, 11, 17	23245.....15	35821 S.....31	35866.....23
22564 J.....13	23420 CC18-1/8.....15	35821 V.....31	35869 C.....17
22569 B.....9	23421 CC18-1/8.....15	35822 W.....19, 31	35869 D.....17
22570.....9	23422 CC18-1/8.....15	35824 BQW9.....35	35869 K.....17
22570 A.....9	23423 V.....15	35824 DW18.....35	35869 L.....17
22571 B.....19	23423 W.....15	35824 DX8.....35	35870.....17
22571 E.....15	25 B.....17	35824 DX9.....35	35871 A.....9
22572 B.....25	258.....31	35825 AC.....21	35871 B.....9
22574.....31	258 A.....23	35826 CB.....27	35873 AH.....27
22580 D.....19	269.....21, 23, 31	35826 DLW9.....35	35873 AJ.....27
22585 A.....19	28.....11	35826 DX.....35	35873 AK.....27
22585 C.....13, 27	28604 R.....38	35826 DZ.....27	35873 W.....27
22587 B.....19	29101 K.....23	35826 X.....27	35873 Z.....27
22587 E.....21, 23	29103 T.....21	35829 AC.....17	35874 B.....35
22587 H.....21	29103 U.....21	35830 DWW18.....35	35875 AA.....27
22589.....31	29472 AC.....19	35830 DWW8.....35	35875 X.....27
22596.....13, 15	29472 AD.....19	35830 DWW9.....35	35875 Y.....27
22596 B.....19	29478 BY.....33	35830 K.....35	35875 Z.....27
22599.....35	29478 CZ.....13	35831 C.....27	35876 AA.....17
22644 K-80.....31	29478 DM.....25	35831 G.....17	35876 AB.....33
22653 B-16.....17	29478 DV.....19, 21	35833 C.....27	35876 AD.....33
22653 B-8.....17	29478 DZ.....19, 25	35833 D.....27	35876 AE.....33
22653 E-20.....11	29478 EB.....19, 21	35833 E.....27	35876 AF.....33
22711.....11, 21, 25	29478 EC.....19, 23	35833 F.....29	35876 AG.....33
22729.....19	29478 ED.....27	35834 AA.....21	35876 AH.....33
22729 C.....21, 23, 31	29480 ALY.....31	35834 AB.....21	35876 U.....11
22729 D.....25	318.....17	35834 AC.....21	35876 V.....31
22730.....11	33174 B.....21	35834 W.....21	35877 AA.....27
22733 B.....9, 11	35704 C.....11	35834 X.....21	35877 N.....31

## NUMERICAL INDEX OF PARTS

<u>Part No.</u>	<u>Page No.</u>	<u>Part No.</u>	<u>Page No.</u>	<u>Part No.</u>	<u>Page No.</u>	<u>Part No.</u>	<u>Page No.</u>
35877 XA.....	31	36236 C.....	23	51292 F-4.....	29	89.....	17, 27
35877 Z.....	31	36236 G.....	21	52888 B.....	29	90.....	9, 19
35878 F.....	29	36236 H.....	21, 23	531.....	13, 15	93.....	9, 11
35878 H.....	29	36236 J.....	21	538.....	13, 33	93 A.....	9
35878 S.....	27	36236 K.....	21	54274 C.....	27	94.....	29
35880 K.....	27	36237.....	21	54274 H.....	33	98 A.....	29
35880 L.....	29	36237 A.....	21	54274 L.....	33	C 067 E.....	9
35880 N.....	29	36237 E.....	13	54274 N.....	33	C 50092 S.....	29
35880 P.....	29	36237 F.....	13	54274 Y.....	33	CL 21.....	9, 11, 17
35883 G.....	13	36237 H.....	13	54279.....	33	J 87 J.....	13
35883 N.....	13	36237 J.....	13	55287 L.....	29	P 51-184 BLK.....	25
35883 P.....	13	36237 K.....	13	56341 G.....	25	TT 85.....	38
35883 R.....	13	36238.....	13	56354 A.....	19	WO 3.....	19, 21, 23
35883 S.....	13	36238 E.....	13	56390 E.....	9	WR 56.....	38
35883 T.....	13	36244.....	21	56392 F.....	29	WR 58.....	38
35883 U.....	13	36244 A.....	21	57 WB.....	17	WR 60.....	38
35883 V.....	15	36249 A.....	13	57 WD.....	17		
35884 D.....	13	36249 B.....	25	60078 Z.....	13		
35884 M.....	15	36256 B.....	15	6042 A.....	9, 17, 31		
35887 AD.....	9	36261 B.....	19	605.....	17		
35887 AE.....	9	36278 C.....	25	605 A.....	33		
35887 M.....	9	36280 U.....	27	61256 G.....	27		
35887 R.....	9	36280 V.....	27	61257 G.....	27		
35887 V.....	11	36280 W.....	29	61321 J.....	31		
35887 X.....	9	36282.....	15	61321 L.....	31		
35887 Z.....	11	36283 C.....	13	61351 C.....	31, 33		
35888 L.....	29	36284.....	13	62238 A.....	21, 23		
35888 M.....	29	36284 C.....	13	642-423 BLK.....	15		
35888 NR.....	9	36284 E.....	15	652 C-9.....	25		
35888 P.....	9	36284 F.....	15	652 K-24.....	13		
35889 AA.....	17	36286.....	13	660-1012.....	38		
35889 B.....	17	36286 A.....	13	660-1014.....	9		
35889 G.....	17	36290 B.....	11	660-1016.....	9		
35889 H.....	9	36292 K.....	29	660-202.....	19		
35889 X.....	17	36292 M.....	29	660-206.....	9, 21, 25		
35889 Y.....	17	36292 N.....	29	660-207.....	21, 23		
35889 Z.....	17	36292 P.....	29	660-219.....	33		
35890 D.....	11	36293 B.....	9	660-219 S.....	29		
35890 E.....	11	36293 E.....	9	660-220.....	13		
35890 L.....	9	36293 F.....	9	660-240.....	38		
35890 M.....	9	36293 G.....	15	660-303.....	27		
35894 K.....	19	36298 F.....	29	660-310.....	25		
35894 V.....	19	36298 G.....	29	660-311.....	25		
35895 V.....	19	39592 AK.....	29	660-457.....	38		
35895 W.....	19	39593 C.....	9	660-935.....	9		
35895 Z.....	19	40-107.....	15	661-150.....	15		
35897 AW.....	9, 17	402.....	27	664 F-16.....	17		
35897 BU.....	19	41071 G.....	9	666-149.....	19		
35897 BV.....	19	41255 B.....	21	666-186.....	31		
35897 BW.....	19	41363 U.....	33	667 B-20.....	17		
35897 BY.....	19	43246.....	23	667 C-12.....	17		
35897 CC.....	19	43296.....	17	667 D-16.....	13		
35897 CH.....	19	4761.....	31	69 H.....	17		
36 G.....	31	50-458 BLK.....	25	73 C.....	27		
36229 A1.....	13	50-537 BLK.....	9	77.....	17, 19, 21		
36234 C.....	21	50-539 BLK.....	11	80265.....	19		
36234 D.....	21	50-834 BLK.....	33	8372 A.....	9		
36234 F.....	21	50-835 BLK.....	33	86.....	27		
36234 G.....	21	50342 V.....	31	87 A.....	13		
36236 A.....	21, 23	51054.....	19	87 U.....	21		
36236 B.....	21, 23	51254 J.....	19	88.....	27		

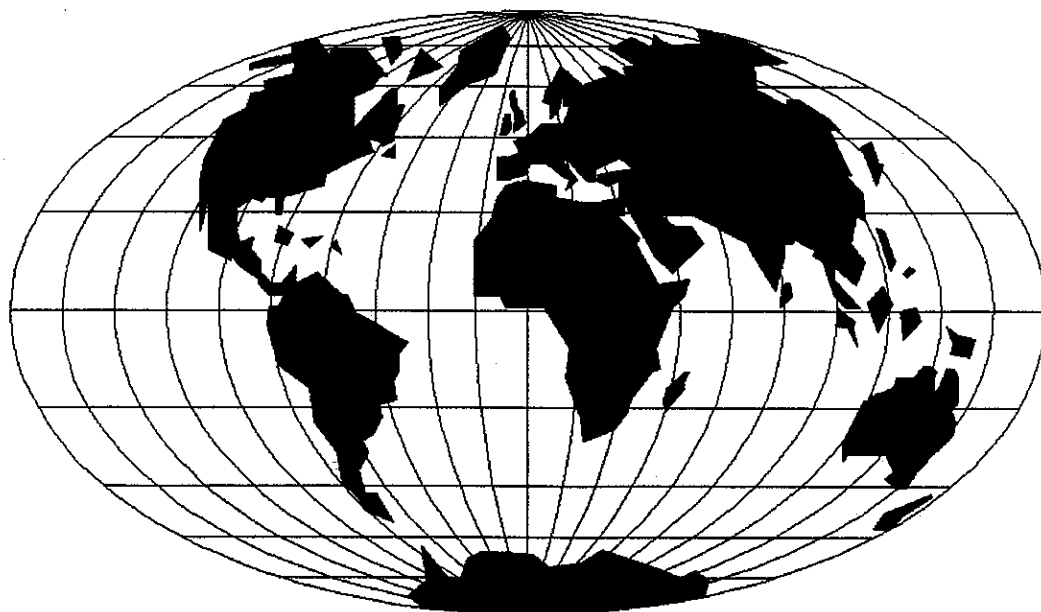

## WORLDWIDE SALES AND SERVICE

Union Special Corporation maintains sales and service facilities throughout the world. These offices will aid you in the selection of the right sewing equipment for your particular operation. Union Special Corporation representatives and service technicians are factory trained and are able to serve your needs promptly and efficiently. Whatever your location, there is a qualified representative to serve you.

---

Brussels, Belgium  
Charlotte, N.C.  
El Paso, TX  
Hong Kong, China  
Huntley, IL  
Leicester, England  
Lille, France  
Miami, FL  
Milan, Italy  
Möglingen, Germany  
Montreal, Quebec  
Osaka, Japan  
Santa Fe Springs, CA

Other Representatives throughout  
all parts of the world.



*Union Special*  
INDUSTRIAL SEWING EQUIPMENT