

SINGER
263-1

SINGER

263-1

PARTS

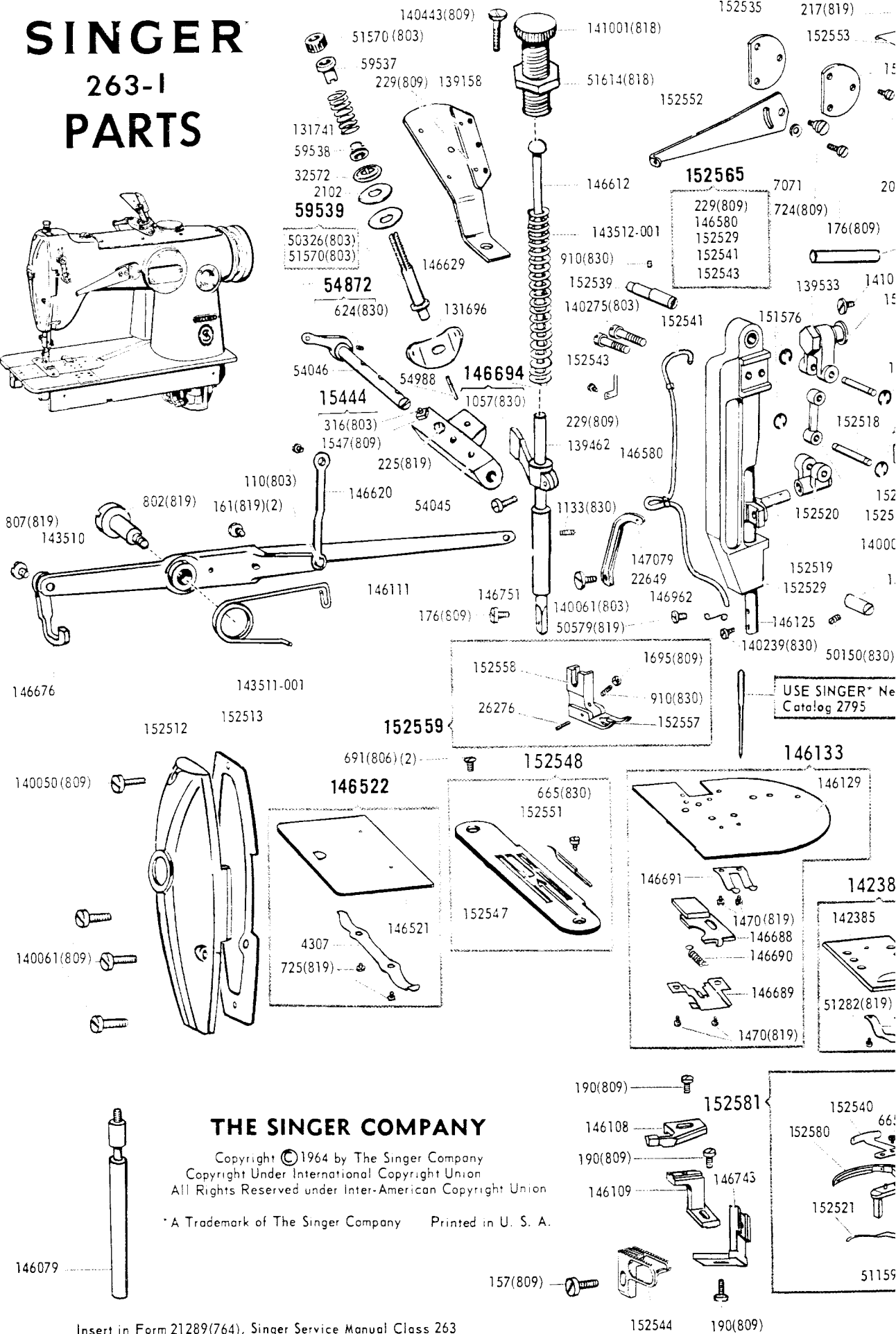
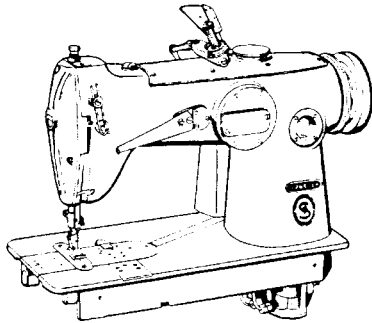

THE SINGER COMPANY

Copyright ©1964 by The Singer Company
Copyright Under International Copyright Union
All Rights Reserved under Inter-American Copyright Union

* A Trademark of The Singer Company Printed in U. S. A.

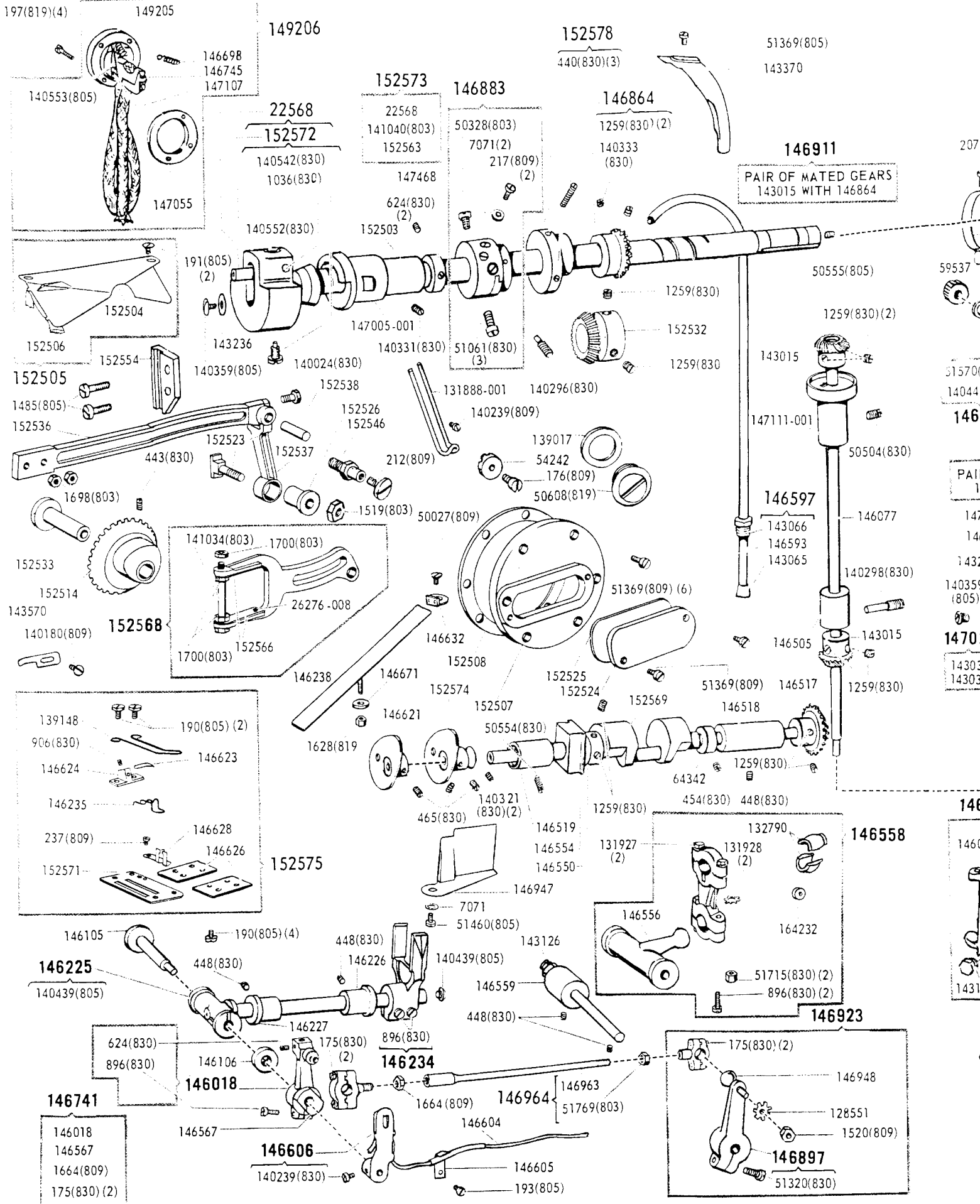

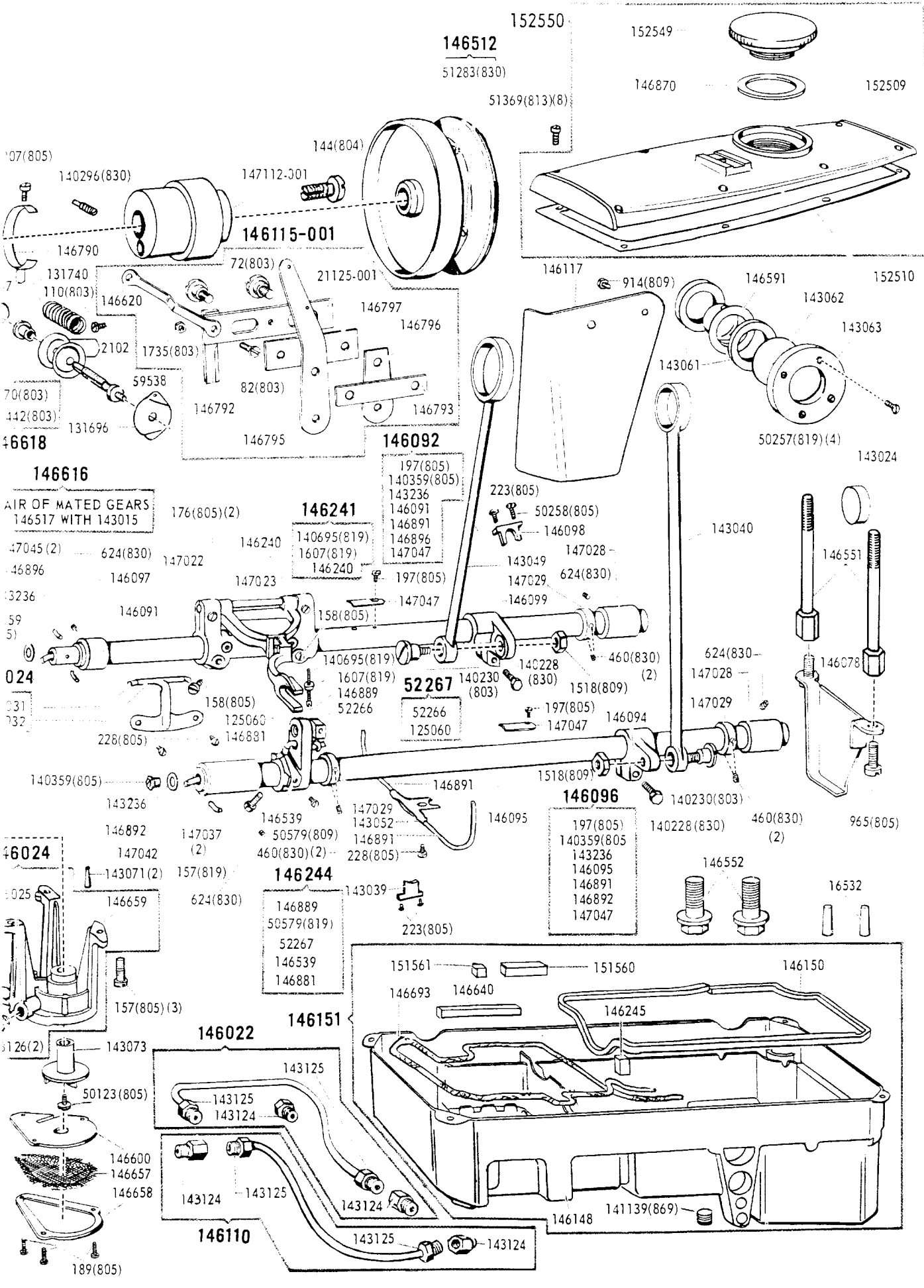

146512

51283(830)

152550

51369(813)(8)

152549

146870

152509

14707(805)

140296(830)

147112-301

144(804)

146115-001

146790

131740

110(803)

146620

72(803)

21125-001

146797

146796

70(803)

142(803)

146618

2102

1735(803)

59538

82(803)

146792

146795

146092

197(805)

140359(805)

143236

146091

146891

146896

147047

146241

140695(819)

1607(819)

146240

146240

147023

147022

146097

13236

59

51

024

031

032

146091

158(805)

125060

146881

228(805)

52267

140695(819)

1607(819)

146889

52266

52266

125060

223(805)

50258(805)

146098

143049

147029

146099

147028

624(830)

143040

146551

146078

624(830)

147028

147029

140359(805)

143236

146892

146024

146025

146026

146027

146028

146029

146030

146031

146032

146033

146034

146035

146036

146037

146038

146039

146040

146041

146042

146043

146044

146045

146046

147037

147037

147042

143071(2)

146659

157(819)

624(830)

157(805)(3)

143073

146026

146027

50123(805)

146600

146657

146658

146600

146657

146658

189(805)

146022

146151

146110

146096

197(805)

140359(805)

143236

146095

146891

146892

147047

146096

140359(805)

143236

146095

146891

146892

147047

151561

151560

146150

146693

146640

146693

146693

146693

146693

146693

146693

146693

146693

146693

146693

146693

146693

146693

146693

146693

146693

146245

146245

146245

146245

146245

146245

146245

146245

146245

146245

146245

146245

146245

146245

146245

146245

16532

16532

16532

16532

16532

16532

16532

16532

16532

16532

16532

16532

16532

16532

16532

16532

16532

16532

16532

16532

16532

16532

AIR OF MATED GEARS
146517 WITH 143015

NUMERICAL LIST OF PARTS MACHINE 263-1

NUMBER	DESCRIPTION	NUMBER	DESCRIPTION	NUMBER	DESCRIPTION
147107	Oil Removing Wick (head end)	152548 [†]	Throat Plate complete, for 1/16" Regular, 3/32", 1/8" bight, 665, 152547 and 152551	12361	Machine Hinge Connection (2)
147108	Wick (head end) Holder Body 146745 with 146698 and 147107	152549	Screw Cap	151559	Rest Pad (rubber) (4)
147111-001	(For Agents only) Bushings (upper)	152550	Arm Top Cover and Screw Cap complete, 146870, 152509 and 152549	232333(805)	Rest Pad Nail 5/8" #17 barbed (flat head) (4)
147112-001	Flanged Bushing (back)	152551 [†]	Throat Plate Insert for 1/16" Regular, 3/32", 1/8" bight	41400	Rest Pin
147468	Thrust Collar with two 457	152552	Thread Eyelet	120344	Oiler (not filled)
149205	Hinge Plate and Cover	152553	Cover	121741	1 Qt. Can Oil
149206	Wick (head end) Holder Body complete, 140553, 146698, 146745, 147055, 147107 and 149205	152554	Slide Block Guide	120341	Tweezers
151560	Machine Pad (felt, left back)	152555	Slide Block	151109	Thread Unwinder complete
151561	Machine Pad (felt, left front)	152556	Contact Pin		KNEE LIFTER
151576	Retaining Ring (4)	152557 [†]	Presser Foot Plate for 1/16" Regular, 3/32", 1/8" bight	146168	Chain, 13-1/2" long with two hooks
152503	Bushing (center)	152558	Presser Foot Shank with 910 and 1695	12501	Pulley
152504	Oil Shield	152559 [†]	Presser Foot (hinged) complete for 1/16" Regular, 3/32", 1/8" bight, 26276, 152557 and 152558	141054(850)	Pulley Hinge Screw Stud
152505	Oil Shield 152504 with 152506	152563	Connection Link 152517 with 139533, 140003, 152519, 152520, 152522, 152555, two 152518 and four 151576	1608(850)	Stud Nut
152506	Oil Wick	152565	Needle Bar Frame 152529 with 229, 146580, 152541 and 152543	146169	Rock Shaft
152507	Arm Side Cover	152566	Regulator Liner (2)	146171	Crank Collar with two set screws
152508	Gasket	152568	Regulator (forked) with 141034, two each 26276-008, 152566 and three 1700	143283	Knee Arm
152509	Arm Top Cover	152569	Bed Rotary Shaft	147489	Knee Arm Hub with two screws
152510	Gasket	152571	Stripper Plate	2767	Arm Plate with set screw
152512	Face Plate	152572	Arm Shaft (horiz.) with 1036, 140542 and Crank	146236	Lifting Lever with set screw
152513	Gasket	152573	Arm Shaft (horiz.) 22568 with 141040 and 152563	146768	Spring
152514	Bevel Gear and Cam	152574	Take-up (left) with two 465	1115(819)	Spring Screw
152517	Connecting Link	152575	Stripper Plate 152571 with 237, 139148, 146623, 146624, 146626, 146628 and two 190	147483	Stop Dog with clamping screw (2)
152518	Hinge Pin (2)	152576	Bed Rotary Shaft 152569 with 132790, 146556, 164232 and two 131928 (For Agents only)		
152519	Connecting Stud with 140061	152578	Feed Lifting Eccentric with three 440		
152520	Stud Connection	152579	Combination: Feed and Stitch Regulator 143015, 143040, 143049, 146864, 146883 and 152578 (For Agents only)		
152521	Looper Thread Retainer (bottom)	152580	Looper		
152522	Crank Connection	152581	Looper 152580 with 665, 51159, 152521 and 152540		
152523	Adjusting Stud	164232	Sleeve Guide		
152524	Adjusting Stud Cover				
152525	Gasket				
152526	Stud Sleeve				
152529	Needle Bar Frame				
152532	Pinion with two 1259				
152533	Gear Stud				
152534	Gear Stud Cover				
152535	Gasket				
152536	Driving Lever with 140024				
152537	Driving Lever Connection				
152538	Connection Pin				
152539	Hinge Pin (eccentric)				
152540	Looper Thread Retainer (side)				
152541	Oil Wick with 146580				
152543	Wick Clamp (intermediate)				
152544	Feed Dog, 17 teeth (16 teeth to inch) Regularly furnished				
152546	Hinge Stud				
152547 [†]	Throat Plate (small needle hole) for 1/16" Regular, 3/32", 1/8" bight				

ACCESSORIES

KNEE LIFTER

STYLE OF FINISH:

When ordering screws, nuts and similar parts include new code numbers which follow parts numbers on illustrations and in the List of Parts.

NEW CODE	OLD CODE	FINISH
803	C	Hardened only
804	D	Polished only
805	E	Soft, not polished
806	F	Hardened and polished
809	J	Nickel plated only
813	R	Phosphate coating formed on surface of iron or steel
818	W	Polished and nickel plated
819	X	Black oxide for iron and steel
823	A. B.	Hardened, polished, buffed and chromium plated
830	A. L.	Heat treated for toughness
850	X. C.	Hardened and black oxide for iron and steel
869	-	Commercial finish for "ALLEN" type screws

[†]State Bight Required

NUMERICAL LIST OF PARTS MACHINE 263-1

NUMBER	DESCRIPTION	NUMBER	DESCRIPTION	NUMBER	DESCRIPTION
146022	Oil Pipe with two each 143124 and 143125	146244	Rock Shaft Crank (front) 146689 with 50579, 52267, 146539 and 146881	146691	Slide Spring
146024	Oil Pump Body 146659 with 146025 and two 143126	146245	Position Pad (felt)	146693	Oil Return Wick
146025	Plug	146505	Bushing (lower)	146694	Guide Bracket with 1057 Spring
146077	Arm Shaft (upright)	146512	Machine Pulley (disc, power) "V" belt groove (outside diam. groove 2.9") with two 51283	146698	Pitman End Bearing (left) with two 175
146078	Bed Leg (back)	146517	Bevel Gear with two 1259	146730	Looper Holder 146018 with 1664, 146567 and two 175
146079	Bed Leg (front, long)	146518	Bushing (back)	146741	Bracket
146091	Feed Rock Shaft	146519	Bushing (front)	146743	Wick (head end) Holder Body
146092	Feed Rock Shaft complete, 197, 140359, 143236, 146091, 146891, 146896, 147047 and suitable length of #1229 white lighter wicking	146521	Bed Slide (left)	146751	Bushing (lower)
146094	Crank with 140228	146522	Bed Slide (left) complete, 4307, 146521 and two 725	146752	Stop with 190 (NOT Regularly Furnished)
146095	Lifting Rock Shaft	146539	Wick Holder	146790	Oil Sump Tube
146096	Lifting Rock Shaft complete, 197, 140359, 143236, 146095, 146891, 146892, 147047 and suitable length of #1229 white lighter wicking	146550	Looper Avoiding Eccentric two 1259	146792	Tension (looper thread) Releaser
146097	Bushing (front)	146551	Arm Screw Stud (back) (2)	146793	Fastening Plate
146098	Cap	146552	Arm Screw (front) (2)	146795	Tension Uncurler
146099	Rock Shaft Crank (back) with 140228	146554	Slide Block	146796	Uncurler Plate (back)
146105	Hinge Pin	146556	Ball Crank	146797	Uncurler Plate (front)
146106	Spacer	146557	Crank Connection with two 131928 (For Agents only)	146864	Bevel Gear with 140333 and two 1259
146108	Needle Guard	146558	Crank Connection with 132790, 146556, 164232 and two 131928 (For Agent only)	146870	Gasket
146109	Needle Guard Holder	146559	Hinge Pin	146874	Spring
146110	Oil Pipe with two each 143124 and 143125	146567	Bushing (eccentric)	146881	Oil Wick
146111	Lever Extension	146580	Oil Wick Clip (2)	146883	Feed Eccentric (adjustable) complete, 50328, two each 217 and 7071 and three 51061
146115-001	Tension (looper thread) Releaser, 82, 1735, 21125-001, 146620, 146792, 146793, 146795, 146796, 146797 and two 72	146591	Oil Flow Body	146889	Crank (front) with 157
146117	Thread Guard 147079	146593	Oil Pipe	146891	Oil Wick (2)
146125	Needle Bar with 140239	146597	Oil Pipe complete (from Pump to Horiz. Arm Shaft Center Bearing), 146593 with 143065 and 143066 (For Agents only)	146892	Oil Wick (long)
146126	Needle Bar complete, 50579, 146125 and 146962	146600	Oil Pump Cover	146896	Oil Wick (long)
146129	Bed Slide (right) Body	146604	Oil Wick	146897	Crank Arm with 51320
146133	Bed Slide (right) Latch complete, 146129, 146688 to 146691 and four 1470, for Throat Plates with .116 off-set	146605	Wick Holder	146911	Pair of Mated Gears 143015 and 146864 (For Agents only)
146148	Machine Base and Oil Reservoir 141139(869)	146606	Position Bracket with 140239	146919	Pitman Head (right) with 146948 and two 175 (For Agents only)
146150	Gasket (left)	146612	Guide Pin	146923	Crank Arm 146897 with 1520, 128551, 146948 and two 175
146151	Machine Base and Oil Reservoir	146616	Pair of Mated Gears 143015 and 146517 (For Agents only)	146947	Oil Shield
146225	Rock Shaft with 140439	146618	Screw Stud 140442 with 51570	146948	Screw Stud (right)
146226	Bushing (back)	146620	Connecting Link (2)	146962	Thread Guide
146227	Bushing (front)	146621	Take-up (right) with 465	146963	Pitman Rod
146234	Eccentric Connection (forked) with two 896	146623	Take-up Stripper	146964	Pitman Rod 146963 with 51769
146235	Stripper Staple (left)	146624	Stripper Holder with 906	147005-001	Flanged Bushing (front)
146238	Thread Tube	146626	Support Plate (2)	147022	Feed Bar Carrier with two 158 and 176
146240	Feed Bar	146628	Thread Guide (right)	147023	Hinge Pin
146241	Feed Bar 146240 with 1607 and 140695	146629	Guide Bracket	147024	Wick Holder 143032 with 143031
146243	Feed Bar Assembly, 146241 and 146244 (For Agents only)	146632	Thread Guide	147028	Bushing (back) (2)
		146640	Machine Pad (felt)	147029	Collar with two 460 (2)
		146657	Screen	147037	Oil Wick (short) (2) (For Agents only)
		146658	Screen Frame	147042	Bushing (front)
		146659	Oil Pump Body	147045	Oil Wick (short) (2) (For Agents only)
		146671	Washer	147047	Wick Clamping Plate (2)
		146676	Bracket Lifter	147055	Gasket
		146688	Latch	147079	Thread Eyelet Bushing
		146689	Latch Guide		
		146690	Latch Spring		

NUMERICAL LIST OF PARTS MACHINE 263-1

NUMBER	DESCRIPTION	NUMBER	DESCRIPTION	NUMBER	DESCRIPTION
72(803)	Hinge Screw (2)	1700(803)	Clamping Screw Nut (3)	139017	Plug Screw Washer
82(803)	Hinge Screw	1735(803)	Hinge Screw Nut	139148	Stripper Staple (right)
110(803)	Hinge Screw (3)	2102	Tension Disc (4)	139158	Thread Guide
144(804)	Arm Shaft Screw (back)	4307	Slide Spring	139462	Presser Bar
157(805)	Screw (3)	7071	Washer (4)	139533	Connection Cap
157(809)	Feed Dog Screw	15444	Stop Screw 3/16 with 1547	140003(803)	Slide Block Screw
157(819)	Clamping Screw	16532	Arm Dowel Pin (2)	140024(830)	Clamping Screw
158(805)	Clamping Screw (2)	21125-001	Releaser Slide	140050(809)	Face Plate Screw (upper)
161(819)	Extension Screw (2)	22568	Arm Shaft (horizontal) 152572 with stud	140061(803)	Clamping Screw
175(830)	Cap Screw (4)	22649	Thread (needle) take-up with 147079	140061(809)	Face Plate Screw (lower) (3)
176(805)	Clamping Screw (2)	26276	Hinge Pin	140180(809)	Set Screw
176(809)	Screw (3)	26276-008	Liner Pin (2)	140228(830)	Clamping Screw (2)
189(805)	Frame Screw (3)	32572	Releasing Disc	140230(803)	Hinge Screw (2)
190(805)	Plate Screw (4)	50027(809)	Guide Screw	140239(809)	Position Screw
190(809)	Screw (7)	50123(805)	Locking Screw	140239(830)	Screw (2)
191(805)	Oil Shield Screw (2)	50150(830)	Set Screw	140275(803)	Lever Screw (2)
193(805)	Bracket Screw	50257(819)	Cap Screw (4)	140296(830)	Set Screw (2)
197(805)	Plate Screw (2)	50258(805)	Cap Screw (long)	140298(830)	Set Screw
197(819)	Screw (4)	50326(803)	Screw Stud	140321(830)	Screw (2)
202(809)	Cover Screw (3)	50328(803)	Feed Regulating Screw	140331(830)	Set Screw
207(805)	Tube Holder Screw	50504(830)	Set Screw	140333(830)	Position Screw
212(809)	Cap Screw	50554(830)	Set Screw	140359(805)	Plug Screw (3)
217(809)	Screw (3)	50555(805)	Plug Screw	140439(805)	Oil Plug Screw
223(805)	Cap Screw (3)	50579(809)	Wick Holder Screw	140442(803)	Screw Stud
225(819)	Stud Hole Plug	50579(819)	Guide Screw	140443(809)	Bracket Screw
228(805)	Wick Holder Screw (3)	50608(819)	Arm Hole Plug Screw	140542(830)	Position Screw
229(809)	Screw (3)	51061(830)	Set Screw (3)	140552(830)	Clamping Screw
231(805)	Oil Plug Screw	51159(804)	Retainer (bottom) Screw	140553(805)	Hinge Screw
237(809)	Plate Screw	51282(819)	Spring Screw	140695(819)	Stop Screw
316(803)	Stop Screw	51283(830)	Set Screw (2)	141001(818)	Thumb Screw
440(830)	Set Screw (3)	51320(830)	Clamping Screw	141034(803)	Clamping Screw
443(830)	Set Screw	51369(805)	Oil Lead Screw	141040(803)	Retaining Screw
448(830)	Set Screw (5)	51369(809)	Screw (8)	141139(869)	Drain Plug
454(830)	Set Screw	51369(805)	Screw (8)	142385	Attachment Slide
460(830)	Set Screw (6)	51460(805)	Oil Shield Screw	142386	Attachment Slide complete, 51282, 142385 and 146874
465(830)	Set Screw (3)	51570(803)	Thumb Nut (2)	143015	Bevel Gear, with two 1259 (2)
624(830)	Set Screw (8)	51614(818)	Thumb Screw Nut	143024	Bed Hole Plug
665(804)	Retainer (side) Screw	51715(830)	Screw Stud Nut (2)	143031	Oil Wick (felt)
665(830)	Insert Screw	51769(803)	Pitman Rod Nut	143032	Wick Holder
691(806)	Throat Plate Screw (2)	52266	Slide Block	143039	Cap
724(809)	Eyelet Screw	52267	Slide Block 52266 with 125060	143040	Connecting Rod
725(819)	Spring Screw (2)	54045	Tension Bracket	143049	Connecting Rod
802(819)	Hinge Screw	54046	Releasing Shaft	143052	Wick Holder
807(819)	Hinge Screw	54242	Controller Clamp	143061	Gasket (2)
896(830)	Screw (5)	54872	Crank with 624	143062	Oil Flow Window
906(830)	Set Screw	54988	Releasing Pin	143063	Window Cap
910(830)	Set Screw (2)	59537	Spring Bushing (large) (2)	143065	Clamping Sleeve
914(809)	Thread Guard Screw	59538	Spring Bushing (small) (2)	143066	Sleeve Nut
965(805)	Bed Leg Screw (back) (2)	59539	Screw Stud 50326 with 51570	143071	Position Pin (2)
1036(830)	Set Screw	64342	Collar with 454	143073	Impeller
1057(830)	Clamping Screw	125060	Hinge Stud	143124	Clamping Sleeve (4)
1133(830)	Set Screw	128551	Locking Plate	143125	Sleeve Nut (4)
1259(830)	Set Screw (12)	131696	Thread Guide (2)	143126	Sleeve Adaptor (4)
1470(819)	Screw (4)	131740	Tension Spring	143236	Washer (fiber) (3)
1485(805)	Guide Screw (2)	131741	Tension Spring	143370	Oil Lead
1518(809)	Hinge Screw Nut (2)	131888-001	Slack Thread Controller	143492	Wick Guide Tube (in arm)
1519(803)	Stud Nut	131927	Screw Stud (2)	143510	Lifting Lever
1520(809)	Screw Stud Nut	131928	Lock Washer (2)	143511-001	Lever Spring
1547(809)	Stop Screw Nut	132790	Ball Sleeve (two pieces)	143512-001	Presser Bar Spring
1607(819)	Stop Screw Nut			143570	Thread Guide
1628(819)	Screw Stud Nut			146018	Looper Holder with 896 and 624
1664(809)	End Bearing Nut				
1695(809)	Set Screw Nut				
1698(803)	Lever Screw Nut (2)				