

SINGER
248-2

LIST OF PARTS



SINGER**

MACHINE No. 248-2

THE SINGER MANUFACTURING COMPANY

INSTRUCTIONS FOR OILING

To ensure easy running and prevent unnecessary wear of the parts which are in movable contact, the machine requires oiling, and when in continuous use, "TYPE B" or "TYPE D" OIL, sold by Singer Sewing Machine Company, should be applied at least twice each day to all oil holes marked "OIL", as instructed in Form 20098.

"TYPE D" OIL should be used when an oil is desired which will produce a minimum of stain on fabrics, even after a long period of storage.

Oiling places are painted with vermilion lacquer.

I N D E X

	Page
Accessories	10
Binders	11
Cable—From Oscillator to Transmitter	23
Edge Folder on Throw-out Shank	12
Edge Folding Strip Guide	12
Electrical Parts	14
Fill-in Plate with Adjustable Edge Guide	13
Foot Treadle Micro Switch	23
Hemmers	13
Knee Lifter Parts	24
Machine No. 248-2	7
Numerical List of Parts	25
Oil Reservoir	24
Strip Folder on Throw-out Shank	13
Tuning Unit	24

INSTRUCTIONS FOR ORDERING

In ordering from this list, use ONLY the part NUMBER in the FIRST column.

The number stamped on a Sewing Machine Part is in every case the number of the single part only.

Every combination of parts sent out as such has its specific number, which, although not stamped on the parts, must be used when ordering the combination.

Each number always indicates the SAME PART in whatever list it appears, or for whatever machine.

The letters after some of the numbers indicate the style of finish only, as follows:

- A—Hardened, Polished, Nickel Plated and Buffed
- A.A—Buffed and Chromium Plated
- A.B—Hardened, Polished, Buffed and Chromium Plated
- A.C—Brown Baking Enamel Finish
- A.D—Gray Baking Enamel Finish
- A.E—Hardened, Bright Rumbled and Nickel Plated
- A.F—Hardened, Bright Rumbled, Nickel Plated, Bright Rumbled and Chromium Plated
- A.G—Alumilite, Plain
- A.H—Alumilite, Dyed
- A.J—Polished, Nickel Plated and Chromium Plated
- A.K—Hardened, Polished, Nickel Plated and Chromium Plated
- A.L—Heat Treated for Toughness
 - B—Polished, Nickel Plated and Buffed
 - C—Hardened Only
- C.R—Hardened and Merlized
 - D—Polished Only
 - E—Soft, Not Polished
 - F—Hardened and Polished
- F.J—Hardened, Polished and Nickel Plated
 - G—Bright Rumbled and Nickel Plated
 - H—Blued
 - J—Nickel Plated Only
 - K—Hardened and Nickel Plated
 - L—Brass Plated
 - M—Oxidized
 - N—Japanned, Dull
 - P—Japanned, Bright
- P.P—Wrinkle Finish
 - R—Merlized
 - S—Cadmium Plated
 - T—Copper Plated
- T.A—Hardened, Polished, Copper and Nickel Plated and Buffed
- T.B—Copper and Nickel Plated and Polished
- T.J—Copper and Nickel Plated Only
- T.K—Hardened, Copper and Nickel Plated
- T.L—Copper and Brass Plated
- T.M—Copper Plated and Oxidized

INSTRUCTIONS FOR ORDERING—Continued

- U—Zinc Plated
- V—Silver Plated
- W—Polished and Nickel Plated
- X—Black Oxide, for Iron and Steel
- X.C—Hardened and Black Oxide, for Iron or Steel
- Y—Black Nickel Plated Only
- Z—Chromium Plated
- Z.A—Hardened, Polished, Nickel Plated, Buffed and Chromium Plated
- Z.B—Polished, Nickel Plated, Buffed and Chromium Plated
- Z.C—Hardened and Chromium Plated
- Z.D—Polished and Chromium Plated
- Z.G—Bright Rumbled, Nickel Plated, Bright Rumbled and Chromium Plated
- Z.J—Nickel and Chromium Plated
- Z.T—Copper and Chromium Plated

These letters MUST BE USED when they appear in the list; and AFTER the number as in the list.

In this series:

1 to 1500, 50001 to 51500 and 140001 to 142000 are Screw Numbers

1501 to 1800 and 51501 to 51800 are Nut Numbers

1801 to 2000 and 51801 to 52000 are Roller Numbers

2001 to 50000 and 52001 to 140000 and 142001 to 190000 are Sewing Machine Parts, 190001 and upward are numbers of Electrical Parts.

The figures in the second column refer only to the plates, illustrating the parts, and are NOT TO BE USED in ordering.

Parts marked with an asterisk (*) are furnished only when repairs are made at factory.

FOR

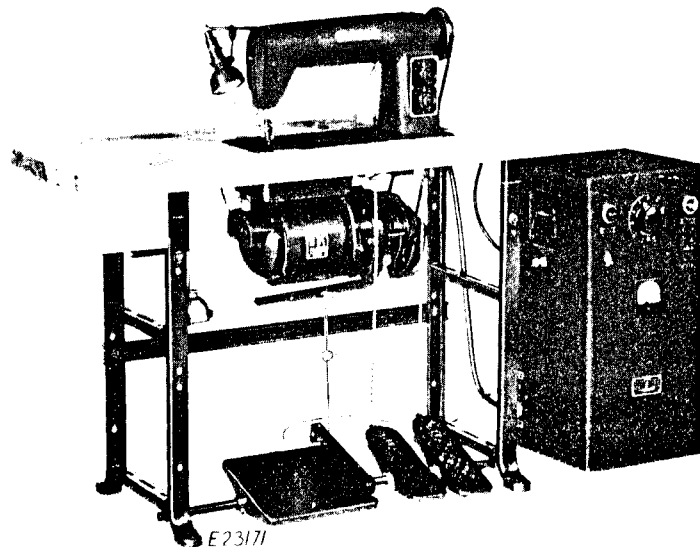

MACHINE NO. 248-2

FOR ELECTRIC SEAMING OF THERMOPLASTICS. ROLLER
PRESSER. DUAL SPEED CONTROL. FOOT LIFTER.

NOTE: The 248-2 Machine consists of Machine Head and Oscillator
only. Other equipment shown above are extra items.

No.	Plate	Name
*169001	Arm with 169052
204235	24731	Arm Dowel Pin (2)
169052	24731	Arm Oil Tube with 169051 (2)
169051	24731	Arm Oil Tube Oil Wick (braided cotton) (2)
200004E	24731	Arm Screw (3)
202005	24731	Arm Screw Washer (3)
169002	24730	Arm Side Cover
140421X	24730	Arm Side Cover Screw (2)
169003	24727	Arm Shaft
270004	24727	Arm Shaft Ball Bearing (back)
270005	24727	Arm Shaft Ball Bearing (front)
*169004	Bed
169005	24728	Bonding Bar (hollow)
270303	24728	Bonding Bar Bushing (lower)
169006	24728	Bonding Bar Bushing (upper)
140321C	24728	Bonding Bar Bushing (upper) Set Screw
169007	24728	Bonding Bar Guide with 1465E
1465E	24728	Bonding Bar Guide Clamping Screw
270264	24728	Bonding Bar Guide Slide
200054E	24728	Bonding Bar Guide Slide Screw (2)
169086	24728	Bonding Bar Lifting Bracket complete, Nos. 1723E, 169085, 169087 and two 50203E
NOTE: When No. 169086 is furnished for Agents orders, include also Bushings No. 169006.		
50203E	24728	Bonding Bar Lifting Bracket Clamping Screw (2)

PARTS FOR MACHINE NO. 248-2

No.	Plate	Name
1723E	24728	Bonding Bar Lifting Bracket Roller Nut
169087	Bonding Bar Lifting Bracket Roller Oil Pad (felt)
169085	24728	Bonding Bar Lifting Bracket Roller Washer
169010	24727	Bonding Bar Lifting Eccentric with two 448AL
448AL	24727	Bonding Bar Lifting Eccentric Set Screw (2)
169011	24728	Bonding Bar Lifting Link
270058	24728	Bonding Bar Oiling Felt
169012	24728	Bonding Bar Regulating Screw Stud
51246AL	24728	Bonding Bar Regulating Screw Stud Set Screw
169013	24728	Bonding Bar Regulating Screw Stud Set Screw Disc (lead)
17862	24728	Bonding Bar Spring
169014	24728	Bonding Bar Stop Plate
1679C	24728	Bonding Bar Stop Plate Lock Nut (2)
126150	24728	Bonding Bar Stop Plate Lock Nut Lock Washer
169089	24728	Bonding Foot with 191ALX, for use with two thicknesses of material
169090	24728	Bonding Foot with 191ALX, for use with three or more thicknesses of material
169091	24728	Bonding Foot with 191ALX, for use with material of uneven thicknesses
51724XC	24728	Bonding Foot Adjusting Nut
51724XC	24728	Bonding Foot Adjusting Nut Lock Nut
191ALX	24728	Bonding Foot Set Screw
169092	24729	Electrode
169088	24729	Electrode Block
169018	24729	Electrode Block Holder
140422X	24729	Electrode Block Holder Screw (2)
931286	24729	Electrode Block Holder Screw Lock Washer (2)
140421X	24729	Electrode Block Screw (2)
701850	24729	Electrode Block Screw Lock Washer (2)
140421X	24729	Electrode Screw (2)
701850	24729	Electrode Screw Lock Washer
169020	24730	Face Plate
140421X	24730	Face Plate Screw (4)
144259	24704	Feed Clutch (brake)
144260	Feed Clutch (brake) 144259 with three 131726
1299AL	24704	Feed Clutch (brake) Set Screw
144261	24704	Feed Clutch (brake) Washer
144262	24704	Feed Clutch (drive)
144263	Feed Clutch (drive) 144262 with three 131726
144264	24704	Feed Clutch Driving Arm
1255C	24704	Feed Clutch Driving Arm Screw (3)
131717	24704	Feed Clutch Roller (6)
68152	24704	Feed Clutch Roller Plunger (6)
131718	24704	Feed Clutch Roller Plunger Spring (6)
169021	24704	Feed Clutch Shaft
169022	Feed Clutch Shaft 169021 with 144269
169023	24704	Feed Clutch Shaft Bushing (2)
54369	24704	Feed Clutch Shaft Collar with two 465AL (2)
465AL	24704	Feed Clutch Shaft Collar Set Screw (4)
144449	24704	Feed Clutch Sleeve with two 140409C
140409C	24704	Feed Clutch Sleeve Set Screw (2)
131726	24704	Feed Clutch Wearing Plate (6)
144269	24704	Feed Clutch complete, Nos. 144260, 144261, 144263, 144264, 144449, three 1255C and six each 68152, 131717 and 131718
52165	24727	Feed Connecting Link
375C	24727	Feed Connecting Link Hinge Screw
1518J	24727	Feed Connecting Link Hinge Screw Nut
52073	24727	Feed Connecting Link Hinge Stud
50083AL	24727	Feed Connecting Link Hinge Stud Set Screw
169024	24727	Feed Eccentric with two 889AL
889AL	24727	Feed Eccentric Set Screw (2)

PARTS FOR MACHINE NO. 248-2

No.	Plate	Name
127152	24727	Feed Eccentric Sleeve
169025	24727	Feed Forked Connection
169026	Feed Forked Connection 169025 with 375C, 1518J and 52165
140432C	24727	Feed Forked Connection Hinge Screw
1722E	24727	Feed Forked Connection Hinge Screw Nut
52408	24727	Feed Regulator with 50083AL
52411	Feed Regulator 52408 with 52073
1128E	24727	Feed Regulator Hinge Screw
169027	24727	Feed Regulating Cam with two 889AL (2)
889AL	24727	Feed Regulating Cam Set Screw (4)
169028	24727	Feed Regulating Cam Shaft (2)
5670	24732	Feed Regulating Chain, 30 in. long, with 56864 and 56865
56864	24732	Feed Regulating Chain Hook (large)
56865	24732	Feed Regulating Chain Hook (small)
169029	24727	Feed Regulating Dial
140202L	24727	Feed Regulating Dial Screw (6)
169030	24727	Feed Regulating Knob with two 1404235 (2)
36006	24727	Feed Regulating Knob Friction Washer (4)
140426X	24727	Feed Regulating Knob Position Screw (2)
1404235	24727	Feed Regulating Knob Set Screw (4)
169031	24727	Feed Regulating Lever with 51846 and 140377R
140377R	24727	Feed Regulating Lever Clamping Screw
169032	24727	Feed Regulating Lever Hinge Screw Stud
169033	24727	Feed Regulating Lever Hinge Screw Stud Arm with 140377R
140377R	24727	Feed Regulating Lever Hinge Screw Stud Arm Clamping Screw
169034	24727	Feed Regulating Lever Hinge Screw Stud Bearing
1516C	24727	Feed Regulating Lever Hinge Screw Stud Lock Nut
51846	24727	Feed Regulating Lever Roller and Stud
169035	24727	Feed Regulating Spring
1387C	24727	Feed Regulating Spring Eyelet
169077	24704	Feed Wheel with two 889AL
889AL	24704	Feed Wheel Set Screw (2)
169072	24729	Filling Plate
270170	24727	Machine Pulley, "V" Belt groove, outside diam. of belt groove 2.9 in., with 350540C and 350541C
350540C	24727	Machine Pulley Set Screw
350541C	24727	Machine Pulley Set Screw
270171	24727	Machine Pulley 270170 with 270004
270269	24728	Presser Bar with 176X
270270	24728	Presser Bar Bushing
169069	24731	Presser Bar Lifter
350442C	24731	Presser Bar Lifter Hinge Screw
270062	24728	Presser Bar Lifting and Releasing Lever Bracket
270095	24728	Presser Bar Lifting and Releasing Lever Bracket Spring
270256	24731	Presser Bar Lifting Link
270285	24731	Presser Bar Lifting Link Connection
446AL	24731	Presser Bar Lifting Link Connection Set Screw
200293C	24731	Presser Bar Lifting Link Hinge Screw
169037	24731	Presser Bar Lifting Rock Shaft with 446AL
169080	24731	Presser Bar Lifting Rock Shaft Arm with 160E and 50269C
160E	24731	Presser Bar Lifting Rock Shaft Arm Clamping Screw
50269C	24731	Presser Bar Lifting Rock Shaft Arm Position Screw
169039	24728	Presser Bar Position Guide with 350411C
350411C	24728	Presser Bar Position Guide Clamping Screw
270271	24731	Presser Bar Spring
350435C	24731	Presser Bar Spring Pressure Screw
270065	24731	Presser Bar Spring Screw Stud
1898XC	24729	Roller, 1 1/4 in. diam., 3/16 in. face, (fine roller) with 386X and 1528X
169048	24729	Roller Arm for 169050R

No.	Plate	Name
12257X	24729	Roller Arm for 12267R
440XC	24729	Roller Arm Adjusting Screw
15446	24729	Roller Arm Adjusting Screw 440XC with 1547X
1547X	24729	Roller Arm Adjusting Screw Nut
6073R	24729	Roller Arm Bracket for 169050
46037R	24729	Roller Arm Bracket for 12267R
316XC	24729	Roller Arm Bracket Screw Center (2)
15444	24729	Roller Arm Bracket Screw Center 316XC with 1547X (2)
1547X	24729	Roller Arm Bracket Screw Center Nut (2)
2205X	24729	Roller Arm Lock Spring
176X	24729	Roller Arm Lock Spring Screw
1549X	24729	Roller Arm Lock Spring Screw Nut
169050R	24729	Roller Presser (right hand) complete, 1-1/4 in. diam., 3/16 in. face (fine roller) Nos. 176X, 1549X, 1898XC, 2205X, 6073R, 15446, 169048 and two 15444
NOTE: No. 169050R is regularly furnished with this Machine.		
12267R	24729	Roller Presser (left hand) complete, 1 1/4 in. diam., 3/16 in. face (fine roller) Nos. 176X, 1549X, 1898XC, 2205X, 12257X, 15446, 46037R and two 15444
NOTE: No. 12267R is shipped as an additional part.		
176X	24728	Roller Presser Screw
386X	24729	Roller Screw
1528X	24729	Roller Screw Nut
169074	24729	Throat Plate
691F	24729	Throat Plate Screw (2)
195582	24731	Tuning Unit (co-axial) Cable Receptacle
208AL	24731	Tuning Unit (co-axial) Cable Receptacle Screw (4)
169041	24730	Tuning Unit Cover
202X	24730	Tuning Unit Cover Screw (8)
169043	24731	Tuning Unit Dial Indicator
140424X	24731	Tuning Unit Screw (3)
931286	24731	Tuning Unit Screw Lock Washer (3)
169045	24731	Tuning Unit Screw Spacer (3)

ACCESSORIES

No.	Plate	Name
217J	24732	Attachment Screw (2)
5670	24732	Chain, 33 1/2 in. long, with 56864 and 56865
56864	24732	Chain Hook (large)
56865	24732	Chain Hook (small)
12361	24732	Machine Hinge Connection (2)
41564	24732	Machine Rest Pin (wood)
120342	24732	Oiler with 120343
120343	24732	Oiler Spout, 3 1/2 in. long
160287	24732	One Quart of heavy grade cloth and leather oil
160669	24732	Screw Driver
820894	24732	Sheet of Crocus Cloth
144465	24732	Hexagon Socket Wrench, for Allen Safety Set Screw 140409 (1/4 x 28)
124165	24732	Wrench
169071	24732	Wrench for 140455 (not regularly furnished)
169079	24732	Wrench for 140490 (not regularly furnished)

BINDERS

BINDER ON THROW-OUT SHANK

FOR 3/4 IN. TO 1 1/4 IN. BINDING

No.	Plate	Name
160638	24744	Binder
1443B	24744	Binder Adjusting Screw (2)
176J	24744	Binder Height Adjusting Screw
1695J	24744	Binder Height Adjusting Screw Lock Nut
140554J	24744	Binder Hinge Screw
121678	24744	Binder Spring
160636	24744	Binder Throw-out Shank
1097J	24744	Binder Throw-out Shank Screw
160639	24744	Binder on Throw-out Shank complete, Nos. 176J, 1097J, 1695J, 121678, 140554J, 160636, 160638 and two 1443B

BINDER (English) ON THROW-OUT SHANK

FOR 1/2 IN. TO 1 IN. BINDING

No.	Plate	Name
160463	24748	Binder (English)
160460	24748	Binder Plate
160461	24748	Binder Throw-out Shank
959J	24748	Binder Throw-out Shank Hinge Screw
35610	24748	Binder Throw-out Shank Hinge Screw Friction Washer
237J	24748	Binder Screw (2)
7071	24748	Binder Screw Washer (2)
160464	24748	Binder (English) on Throw-out Shank complete, Nos. 959J, 35610, 160460, 160461, 160463 and two each 237J and 7071

BINDER (English) ON THROW-OUT SHANK

FOR BINDING 7/8 IN. AND UP, IN STEPS 1/8 IN.

No.	Plate	Name
160471	24748	Binder (English)
160460	24748	Binder Plate
160461	24748	Binder Throw-out Shank
959J	24748	Binder Throw-out Shank Hinge Screw
35610	24748	Binder Throw-out Shank Hinge Screw Friction Washer
237J	24748	Binder Screw (2)
7071	24748	Binder Screw Washer (2)
160472	24748	Binder (English) on Throw-out Shank complete, Nos. 959J, 35610, 160460, 160461, 160471 and two each 237J and 7071

BINDER (Transverse) ON THROW-OUT SHANK

FOR 1/2 IN. TO 1 IN. BINDING

No.	Plate	Name
160473	24749	Binder (transverse)
160460	24749	Binder Plate
160474	24749	Binder Throw-out Shank
959J	24749	Binder Throw-out Shank Hinge Screw
35610	24749	Binder Throw-out Shank Hinge Screw Friction Washer
51097J	24749	Binder Thumb Screw
3146	24749	Binder Thumb Screw Washer
160475	24749	Binder (transverse) on Throw-out Shank complete, Nos. 959J, 3146, 35610, 51097J, 160460, 160473 and 160474

BINDER (Transverse) ON THROW-OUT SHANK
FOR BINDING 1 1/2 IN. AND UP

No.	Plate	Name
160476	24749	Binder (transverse).....
160460	24749	Binder Plate.....
160474	24749	Binder Throw-out Shank.....
959J	24749	Binder Throw-out Shank Hinge Screw.....
35610	24749	Binder Throw-out Shank Hinge Screw Friction Washer.....
51097J	24749	Binder Thumb Screw.....
3146	24749	Binder Thumb Screw Washer.....
160477	24749	Binder (transverse) on Throw-out Shank complete, Nos. 959J, 3146, 35610, 51097J, 160460, 160474 and 160476.....

EDGE FOLDERS

EDGE FOLDER ON THROW-OUT SHANK
UP TO 5/16 IN. FOLD

No.	Plate	Name
160465	24710	Edge Folder.....
160460	24710	Edge Folder Plate.....
160461	24710	Edge Folder Throw-out Shank.....
959J	24710	Edge Folder Throw-out Shank Hinge Screw.....
35610	24710	Edge Folder Throw-out Shank Hinge Screw Friction Washer.....
237J	24710	Edge Folder Screw (2).....
7071	24710	Edge Folder Screw Washer (2).....
160466	24710	Edge Folder on Throw-out Shank complete, Nos. 959J, 35610, 160460, 160461, 160465 and two each 237J and 7071.....

EDGE FOLDER ON THROW-OUT SHANK
FOR 3/8 IN. FOLD AND ABOVE

No.	Plate	Name
160490	24744	Edge Folder.....
160460	24744	Edge Folder Plate.....
160461	24744	Edge Folder Throw-out Shank.....
959J	24744	Edge Folder Throw-out Shank Hinge Screw.....
35610	24744	Edge Folder Throw-out Shank Hinge Screw Friction Washer.....
237J	24744	Edge Folder Screw (2).....
7071	24744	Edge Folder Screw Washer (2).....
160491	24744	Edge Folder on Throw-out Shank complete, Nos. 959J, 35610, 160460, 160461, 160490 and two each 237J and 7071.....

EDGE FOLDING STRIP GUIDE
(Adjustable)
ON THROW-OUT SHANK

No.	Plate	Name
160467	24710	Edge Folding Strip Guide (adjustable).....
160460	24710	Edge Folding Strip Guide Plate.....
160461	24710	Edge Folding Strip Guide Throw-out Shank.....
959J	24710	Edge Folding Strip Guide Throw-out Shank Hinge Screw.....
35610	24710	Edge Folding Strip Guide Throw-out Shank Hinge Screw Friction Washer.....
237J	24710	Edge Folding Strip Guide Screw (2).....
7071	24710	Edge Folding Strip Guide Screw Washer (2).....
160468	24710	Edge Folding Strip Guide (adjustable) on Throw-out Shank complete, Nos. 959J, 35610, 160460, 160461, 160467 and two each 237J and 7071.....

FILL-IN PLATE

WITH ADJUSTABLE EDGE GUIDE

No.	Plate	Name
160478	24711	Edge Guide (adjustable).....
239J	24711	Edge Guide Screw.....
160479	24711	Fill-in Plate with Adjustable Edge Guide complete, Nos. 239J and 160478.....

HEMMERS

HEMMER ON THROW-OUT SHANK

No.	Plate	Name
160459	24711	Hemmer.....
160460	24711	Hemmer Plate.....
160461	24711	Hemmer Throw-out Shank.....
959J	24711	Hemmer Throw-out Shank Hinge Screw.....
35610	24711	Hemmer Throw-out Shank Hinge Screw Friction Washer.....
237J	24711	Hemmer Screw (2).....
7071	24711	Hemmer Screw Washer (2).....
160462	24711	Hemmer on Throw-out Shank complete, Nos. 959J, 35610, 160459, 160460, 160461 and two each 237J and 7071.....

HEMMER (adjustable) ON THROW-OUT ARM

FOR HEM SIZE 1/2 IN. AND ABOVE, FOR HEMMING BOTTOM OF RAINCOATS

No.	Plate	Name
160635	24744	Hemmer.....
1443B	24744	Hemmer Adjusting Screw (2).....
140554J	24744	Hemmer Hinge Screw.....
121678	24744	Hemmer Spring.....
160636	24744	Hemmer Throw-out Arm.....
1097J	24744	Hemmer Throw-out Arm Screw.....
160637	24744	Hemmer (adjustable) on Throw-out Arm complete, Nos. 1097J, 121678, 140554J, 160635, 160636 and two 1443B.....

STRIP FOLDER ON THROW-OUT SHANK

FOR HANGING LOOPS FOR RAINCOATS

No.	Plate	Name
160469	24711	Strip Folder.....
160460	24711	Strip Folder Plate.....
160461	24711	Strip Folder Throw-out Shank.....
959J	24711	Strip Folder Throw-out Shank Hinge Screw.....
35610	24711	Strip Folder Throw-out Shank Hinge Screw Friction Washer.....
237J	24711	Strip Folder Screw (2).....
7071	24711	Strip Folder Screw Washer (2).....
160470	24711	Strip Folder on Throw-out Shank complete, Nos. 959J, 35610, 160460, 160461, 160469 and two each 237J and 7071.....

ELECTRICAL PARTS

SINGER ELECTRONIC OSCILLATOR NO. G16

No.	Plate	Name
195445	24716	Cable with 195446
195446	24716	Cable Adapter Plug (two to three wire)
195447	24736	Cable (co-axial)
195517		Cabinet
195609	24733	Oscillator Cap (Plate) with lead (2)
195613	24733	Oscillator Choke (Grid)
195608	24713	Oscillator Choke (plate)
195612	24733	Oscillator Condenser (By-pass, grid)
50662R	24733	Oscillator Condenser (By-pass, grid) Fastening Screw
1799	24733	Oscillator Condenser (By-pass, grid) Fastening Screw Nut (brass)
195554	24733	Oscillator Coupler (Grid, Extension)
50514	24733	Oscillator Coupler (Grid, Extension) Screw (brass)
50514	24733	Oscillator Coupler (Grid, Extension) Shaft Screw (brass)
50587	24713	Oscillator Coupling Coil Grounding Screw
1799		Oscillator Coupling Coil Ground Screw Nut
190070	24713	Oscillator Grommet (rubber) (2)
50672	24713	Oscillator Plate Tank Condenser Bracket Screw (brass) (4)
931084		Oscillator Plate Tank Condenser Bracket Screw Washer (4)
195554	24733	Oscillator Plate Tank Condenser Extension Coupler
50514	24733	Oscillator Plate Tank Condenser Extension Coupler Screw (brass)
50514	24733	Oscillator Plate Tank Condenser Extension Coupler Shaft Screw (brass)
50672	24733	Oscillator Plate Tank Condenser Stand-off Insulator Screw (2)
931084		Oscillator Plate Tank Condenser Stand-off Insulator Screw Washer (2)
195582	24713	Oscillator Receptacle (Amphenol) Co-axial
50587	24713	Oscillator Receptacle Screw (brass) (4)
1799		Oscillator Receptacle Screw Nut (brass) (4)
195611	24733	Oscillator Resistor (grid)
50976	24733	Oscillator Resistor (grid) Fastening Screw (2)
1799S	24733	Oscillator Resistor (grid) Fastening Screw Nut (6)
50776R		Oscillator Screw (for fastening unit to base of cabinet) (3)
1785		Oscillator Screw Nut (brass) (3)
931084		Oscillator Screw Lock Washer (3)
195610	24733	Oscillator Socket (four-pin) (2)
50976		Oscillator Socket (four-pin) Screw (brass) (4)
1799		Oscillator Socket (four-pin) Screw Nut (brass) (12)
51475R		Oscillator Supporting Bracket Screw (2)
51636J		Oscillator Supporting Bracket Screw Nut (brass) (2)
701850		Oscillator Supporting Bracket Screw Nut Lock Washer (2)
980005	24713	Oscillator Terminal (3)
50841R	24713	Oscillator Terminal Strip (for four contact) Screw (2)
1799		Oscillator Terminal Strip (for four contact) Screw Nut (2)
195614	24713	Oscillator Transformer (filament)
50974J	24713	Oscillator Transformer Screw (4)
51636J	24713	Oscillator Transformer Screw Nut (brass) (4)
701850	24713	Oscillator Transformer Screw Nut Lock Washer (4)
196051	24733	Oscillator Tube (2)
		NOTE: Two additional No. 196051 are sent with each complete Singer Electronic Oscillator.
51475R	24713	Oscillator Tube Shield Supporting Rod Screw (4)
701850	24713	Oscillator Tube Shield Supporting Rod Screw Lock Washer (4)
195453	24713	Oscillator Unit complete, Nos. 50662R, 195582, 195608, 195611, 195612, 195613, 195614, two each 50841R, 190070, 195554, 195609, 195610, 196051, three each 1785, 50776R, 980005, four each 50514, 50974J, five 50587, six each 50672, 50976, 51475R, 51636J, nine 931084, ten 701850 and twenty-six 1799

No.	Plate	Name
195460	24714	Panel Bulb (pilot light, 115V, 6 Watts) (2)
50644R	24714	Panel Capacitor Shaft Cover (Plate and Grid) Screw (4)
195618	24714	Panel Lens (pilot, red)
195617	24714	Panel Lens (pilot, yellow)
195555	24714	Panel Milliammeter
50667	24714	Panel Milliammeter Screw (3)
1787		Panel Milliammeter Screw Nut (brass) (3)
175357		Panel Milliammeter Screw Nut Lock Washer (3)
195616	24734	Panel Powerstat
196292	24734	Panel Powerstat Brush
140455C	24734	Panel Powerstat Brush Wheel Set Screw (2)
195621	24714	Panel Powerstat Dial
50587J		Panel Powerstat Dial Screw (3)
195622	24714	Panel Powerstat Knob with two 140454J
140454J		Panel Powerstat Knob Screw (2)
195553	24734	Panel Powerstat Relay
50782J	24734	Panel Powerstat Relay Screw (2)
50647R	24734	Panel Powerstat Screw (3)
931084		Panel Powerstat Screw Lock Washer (3)
195459	24714	Panel Switch (toggle) (2)
796801	24714	Panel Switch Indicator (off and on) (2)
51623J	24714	Panel Switch Nut (for fastening switch to panel) (2)
980005	24734	Panel Terminal (42)
195619	24734	Panel Terminal Strip
50841J	24734	Panel Terminal Strip Screw (2)
195458	24714	Panel (front) complete, Nos. 195553, 195555, 195616, 195617, 195618, 195619, 195621, 195622, 196292, two each 50782, 50841J, 51623J, 140455C, 195459, 195460, 796801, three each 1787, 50587J, 50647R, 50667, 175357, 931084, four 50644R and forty-two 980005
195624	24716	Power Supply and Filter Unit Choke (filter)
50974J	24716	Power Supply and Filter Unit Choke Screw (4)
51636J	24716	Power Supply and Filter Unit Choke Screw Nut (4)
701850	24716	Power Supply and Filter Unit Choke Screw Nut Lock Washer (4)
195625	24716	Power Supply and Filter Unit Condenser (filter) (2)
140126J	24716	Power Supply and Filter Unit Condenser Position Bracket Clamping Screw (2)
50974J	24716	Power Supply and Filter Unit Condenser Position Bracket Screw (4)
51636J	24716	Power Supply and Filter Unit Condenser Position Bracket Screw Nut (4)
701850	24716	Power Supply and Filter Unit Condenser Position Bracket Nut Lock Washer (4)
195462	24716	Power Supply and Filter Unit Fuse (plug, 5 Amp)
195463	24716	Power Supply and Filter Unit Fuse (plug, 15 Amp)
942522		Power Supply and Filter Unit Lead Clamp
195629	24716	Power Supply and Filter Unit Outlet (duplex)
50791	24716	Power Supply and Filter Unit Outlet Screw (brass) (4)
51475R	24716	Power Supply and Filter Unit Platform (Filter circuit) Screw (4)
51636J		Power Supply and Filter Unit Platform (Filter circuit) Screw Nut (4)
701850		Power Supply and Filter Unit Platform (Filter circuit) Screw Nut Lock Washer (4)
195630	24716	Power Supply and Filter Unit Receptacle (fuse) complete (2)
195626	24716	Power Supply and Filter Unit Resistor (bleeder)
51475R	24716	Power Supply and Filter Unit Resistor (bleeder) Screw (2)
51636J	24716	Power Supply and Filter Unit Resistor (bleeder) Screw Nut (2)
701822	24716	Power Supply and Filter Unit Resistor (bleeder) Screw Nut Lock Washer (2)

ELECTRICAL PARTS

No.	Plate	Name
50776R		Power Supply and Filter Unit Screw (for fastening filter unit to base) (4)
1785		Power Supply and Filter Unit Screw Nut (brass) (4)
931084		Power Supply and Filter Unit Screw Nut Lock Washer (4)
50974J		Power Supply and Filter Unit Screw (for fastening filter unit to cabinet) (2)
51636J		Power Supply and Filter Unit Screw Nut (2)
701850		Power Supply and Filter Unit Screw Nut Lock Washer (2)
51475R	24716	Power Supply and Filter Unit Supporting Bracket Screw
51636J		Power Supply and Filter Unit Supporting Bracket Screw Nut (brass)
701850		Power Supply and Filter Unit Supporting Bracket Screw Nut Lock Washer
980005	24716	Power Supply and Filter Unit Terminal (27)
195623	24736	Power Supply and Filter Unit Transformer (power)
51475R		Power Supply and Filter Unit Transformer Screw (4)
51636J		Power Supply and Filter Unit Transformer Screw Nut (4)
701850		Power Supply and Filter Unit Transformer Screw Nut Lock Washer (4)
195461		Power Supply and Filter Unit complete, Nos. 195462, 195463, 195623, 195624, 195626, 195627, 195628, 195629, 942522, two each 140126J, 195625, 195630, 701822, four each 1785, 50776R, 50791, 931084, ten 50974J, eleven 51475R, nineteen 701850, twenty-one 51636J and twenty-seven 980005
50514		Rectifier Unit Plug (input) Clamp Screw (brass) (2)
1799		Rectifier Unit Plug (input) Clamp Screw Nut (brass) (2)
50841	24735	Rectifier Unit Plug (male) Clamping Screw (brass)
1799	24735	Rectifier Unit Plug (male) Clamping Screw Nut (brass)
701822		Rectifier Unit Plug (male) Clamping Screw Nut Lock Washer (2)
50974R	24735	Rectifier Unit Plug (male) Supporting Bracket Screw (2)
51636J	24735	Rectifier Unit Plug (male) Supporting Bracket Screw Nut (2)
701850		Rectifier Unit Plug (male) Supporting Bracket Screw Nut Locker Washer (2)
195456	24735	Rectifier Unit Safety Switch (micro)
50514		Rectifier Unit Safety Switch Bracket Screw (brass)
1799		Rectifier Unit Safety Switch Bracket Screw Nut (brass)
701822		Rectifier Unit Safety Switch Bracket Screw Nut Lock Washer
195455	24735	Rectifier Unit Safety Switch (Micro) complete, Nos. 1799, 50514, 195456 and 701822.
50776R		Rectifier Unit Screw (2)
1785J		Rectifier Unit Screw Nut (2)
931084		Rectifier Unit Screw Nut Lock Washer (2)
195610	24735	Rectifier Unit Socket (four pin) (2)
50514	24735	Rectifier Unit Socket Screw (brass) (4)
1799	24735	Rectifier Unit Socket Screw Nut (brass) (4)
701822	24735	Rectifier Unit Socket Screw Nut Lock Washer (4)
50841	24735	Rectifier Unit Terminal Strip Screw (brass) (2)
50672		Rectifier Unit Terminal Strip Support Screw (brass) (2)
195615	24735	Rectifier Unit Transformer (filament)
50974R	24735	Rectifier Unit Transformer Screw (3)
51636J	24735	Rectifier Unit Transformer Screw Nut (3)
701850	24735	Rectifier Unit Transformer Screw Nut Lock Washer (3)
195452	24735	Rectifier Unit Tube (2)
NOTE: Two additional No. 195452 are sent with each complete Singer Electronic Oscillator.		
195628	24736	Rectifier Unit Tube Cap (long lead)
195627	24736	Rectifier Unit Tube Cap (short lead)
51475R	24735	Rectifier Unit Tube Platform Supporting Rod Screw (8)
701850	24735	Rectifier Unit Tube Platform Supporting Rod Screw Lock Washer (8)

ELECTRICAL PARTS

No.	Plate	Name
195454	24735	Rectifier Unit complete, Nos. 195455, 195615, two each 1785J, 50672, 50776R, 195452, 195610, 931084, three 50841, four 50514, five each 50974R, 51636J, six each 1799, 701822, eight 51475R and thirteen 701850

ELECTRICAL PARTS

SINGER ELECTRONIC OSCILLATOR NO. G26

No.	Plate	Name
195445	24716	Cable with 195446
195446	24716	Cable Adaptor Plug (two to three wire)
195447	24736	Cable (Co-axial)
195588	24719	Choke (Filter)
506475	24719	Choke (Filter) Screw (4)
701679T	24719	Choke (Filter) Screw Lock Washer (4)
195574	24719	Condenser (Filter)
506475		Condenser (Filter) Screw (2)
701679T		Condenser (Filter) Screw Lock Washer (2)
195463	24737	Fuse (plug, 15 Amp.)
195870	24721	Oscillator Cap (plate) with Lead (2)
1799S	24721	Oscillator Cap (plate) with Lead Nut (2)
701804	24721	Oscillator Cap (plate) with Lead Nut Lock Washer (2)
136325S	24721	Oscillator Cap (plate) with Lead Nut Washer (2)
195589	24721	Oscillator Choke (plate)
195576	24722	Oscillator Condenser (filament) (4)
195579	24722	Oscillator Condenser (grid)
140501S	24721	Oscillator Condenser (grid) Screw (4)
195575	24721	Oscillator Plate Tank Condenser
50514S	24721	Oscillator Plate Tank Condenser Screw (4)
1799S	24719	Oscillator Plate Tank Condenser Screw Nut (4)
931202T		Oscillator Plate Tank Condenser Screw Nut Lock Washer (4)
195582	24719	Oscillator Receptacle (Amphenol) Co-axial
140252S	24721	Oscillator Receptacle (Amphenol) Co-axial Screw (4)
51733S	24719	Oscillator Receptacle (Amphenol) Co-axial Screw Nut (4)
931380T		Oscillator Receptacle (Amphenol) Co-axial Screw Nut Lock Washer (4)
195591	24722	Oscillator Resistor (grid)
50514S		Oscillator Resistor (grid) Fastening Screw (2)
1799S	24722	Oscillator Resistor (grid) Fastening Screw Nut (2)
931202T		Oscillator Resistor (grid) Fastening Screw Nut Lock Washer (2)
195601	24721	Oscillator Socket (2)
50764S	24721	Oscillator Socket Screw (4)
1799S	24722	Oscillator Socket Screw Nut (4)
931202T		Oscillator Socket Screw Nut Lock Washer (4)
701147		Oscillator Socket Screw Nut Washer (fiber) (4)
136358S	24722	Oscillator Socket Screw Nut Washer (steel) (4)
195596	24719	Oscillator Transformer (filament)
50782S		Oscillator Transformer (filament) Screw (4)
701804T		Oscillator Transformer (filament) Screw Lock Washer (4)
196051	24737	Oscillator Tube (2)
NOTE: Two additional No. 196051 are sent with each complete Singer Electronic Oscillator		
195460	24723	Panel Bulb (pilot light, 115V, 6 Watts) (2)
195603	24723	Panel Lens (pilot, amber) with Socket complete
195602	24723	Panel Lens (pilot, red) with Socket complete
195590	24723	Panel Milliammeter
50513S	24724	Panel Milliammeter Screw (4)
931202T	24724	Panel Milliammeter Screw Lock Washer (4)
195577	24724	Panel Milliammeter Condenser (by-pass)
51672S		Panel Milliammeter Condenser Nut (4)

ELECTRICAL PARTS

No.	Plate	Name
151060T		Panel Milliammeter Condenser Nut Lock Washer (4)
67564S		Panel Milliammeter Condenser Washer (2)
195599	24724	Panel Powerstat
195620	24724	Panel Powerstat Brush
195621	24723	Panel Powerstat Dial
50587J		Panel Powerstat Dial Screw (3)
195622	24723	Panel Powerstat Knob with two 140454J
140454J		Panel Powerstat Knob Screw (2)
140500S		Panel Powerstat Screw (3)
195593	24723	Panel Switch (Line Breaker)
195910	24723	Panel Switch Name Plate (Power)
140497R	24723	Panel Switch Name Plate Screw (2)
140498R	24723	Panel Switch Screw (4)
195594	24723	Panel Switch (Tack)
796801	24723	Panel Switch (Tack) Indicator (off and on)
195909	24723	Panel Switch (Tack) Name Plate (Spot Seal)
140497R	24723	Panel Switch (Tack) Name Plate Screw (2)
195583	24719	Receptacle (foot switch)
140502S	24719	Receptacle (foot switch) Screw (2)
195604	24737	Receptacle (fuse)
195581	24738	Receptacle (line input)
51324S	24738	Receptacle (line input) Screw (2)
195580	24719	Receptacle (Motor)
140122S	24719	Receptacle (Motor) Screw (2)
195595	24738	Rectifier Unit Safety Switch (Micro)
51605J	24738	Rectifier Unit Safety Switch Nut (for fastening Micro Switch to bracket)
195600	24738	Rectifier Unit Socket (2)
50672S		Rectifier Unit Socket Screw (2)
701679T		Rectifier Unit Socket Screw Lock Washer (4)
136358S		Rectifier Unit Socket Screw Washer (steel) (4)
701147		Rectifier Unit Socket Screw Washer (fiber) (4)
195597	24737	Rectifier Unit Transformer (Filament)
50782S		Rectifier Unit Transformer Screw (4)
701804T		Rectifier Unit Transformer Screw Lock Washer (4)
195452	24724	Rectifier Unit Tube (2)
NOTE: Two additional No. 195452 are sent with each complete Singer Electronic Oscillator.		
195907	24724	Rectifier Unit Tube Cap with Lead (2)
1783S	24724	Rectifier Unit Tube Cap Nut (2)
701804T		Rectifier Unit Tube Cap Nut Lock Washer (2)
67592		Rectifier Unit Tube Cap Nut Washer (4)
195587	24738	Relay (keying)
50639S		Relay (keying) Screw (4)
931202T		Relay (keying) Screw Lock Washer (4)
195585	24738	Relay (overload, D.C.)
50647S		Relay (overload, D.C.) Screw (2)
701679T		Relay (overload, D.C.) Screw Lock Washer (2)
195584	24738	Relay (plate contactor)
50647S		Relay (plate contactor) Screw (2)
701679S		Relay (plate contactor) Screw Lock Washer (2)
195586	24738	Relay (time delay)
50639S		Relay (time delay) Screw (2)
931202T		Relay (time delay) Screw Lock Washer (2)
195592	24724	Resistor (bleeder)
50514S	24719	Resistor (bleeder) Screw (2)
1799S	24719	Resistor (bleeder) Screw Nut (2)
931202T	24719	Resistor (bleeder) Screw Nut Lock Washer (2)
195908	24719	Resistor (bleeder) Connection (2)
51732S	24719	Resistor (bleeder) Connection Nut (brass) (2)
701348S	24719	Resistor (bleeder) Connection Nut Lock Washer (2)
195598	24737	Transformer (plate)
140499S	24737	Transformer (plate) Screw
151060T	24737	Transformer (plate) Screw Lock Washer

ELECTRICAL PARTS

SINGER ELECTRONIC OSCILLATOR NO. G46

No.	Plate	Name
195445	24716	Cable with 195446
195446	24716	Cable Adaptor Plug (two to three wire)
195447	24736	Cable Co-axial
195608		Choke (Grid)
195608	24743	Choke (Plate)
195574	24719	Condenser (Filter)
50647S		Condenser (Filter) Screw (2)
701679T		Condenser (Filter) Screw Lock Washer (2)
196056	24743	Condenser Eoupler (Grid)
195463	24716	Fuse (plug, 15 Amp.)
196052	24740	Oscillator Cap (plate) with Lead (2)
50692S	24743	Oscillator Chassis Fastening Screw (3)
67193S		Oscillator Chassis Fastening Screw Lock Washer (3)
51601S		Oscillator Chassis Fastening Screw Nut (3)
701511S		Oscillator Chassis Fastening Screw Washer (3)
195576	24722	Oscillator Condenser (filament) (4)
196055	24741	Oscillator Condenser (stand-off) (4)
50514		Oscillator Condenser (stand-off) Mounting Screw (8)
701844		Oscillator Condenser (stand-off) Mounting Screw Washer (8)
196063		Oscillator Condenser (grid) Shaft
196964	24743	Oscillator Condenser (grid) with Lead
196053	24741	Oscillator Plate Tank Condenser
196054	24741	Oscillator Plate Tank Condenser Mounting Bracket (2)
50514S		Oscillator Plate Tank Condenser Screw (4)
1799S		Oscillator Plate Tank Condenser Screw Nut (4)
931202T		Oscillator Plate Tank Condenser Screw Nut Lock Washer (4)
195582	24713	Oscillator Receptacle (Amphenol) Co-axial Cable
140125J	24743	Oscillator Receptacle (Amphenol) Co-axial Cable Screw (4)
51761J		Oscillator Receptacle (Amphenol) Co-axial Cable Screw Nut (4)
196065		Oscillator Resistor (grid) with Bracket
50514S		Oscillator Resistor (grid) Fastening Screw (2)
1799S		Oscillator Resistor (grid) Fastening Screw Nut (2)
196158	24742	Oscillator Rotor Lock (grid)
196158	24741	Oscillator Rotor Lock (plate)
196159		Oscillator Socket (2)
50841J		Oscillator Socket Screw (4)
1799S		Oscillator Socket Screw Nut (4)
701844		Oscillator Socket Screw Washer (4)
195596		Oscillator Transformer (filament)
50782S		Oscillator Transformer (filament) Screw (4)
701804T		Oscillator Transformer (filament) Screw Lock Washer (4)
196051	24740	Oscillator Tube (2)
NOTE: Two additional No. 196051 are sent with each complete Singer Electronic Oscillator.		
195460	24714	Panel Bulb (pilot light, 115 V, 6 Watts) (2)
195603	24723	Panel Lens (pilot, amber) with Socket complete
195602	24723	Panel Lens (pilot, red) with Socket complete
196160	24739	Panel Milliammeter
195577	24724	Panel Milliammeter Condenser (by-pass)
51672S	24741	Panel Milliammeter Condenser Nut (4)
151060T		Panel Milliammeter Condenser Nut Lock Washer (4)
190091S		Panel Milliammeter Condenser Nut Washer (2)
195616	24741	Panel Powerstat
196161		Panel Powerstat Adapter Plate
140620		Panel Powerstat Adapter Plate Screw (3)

ELECTRICAL PARTS

No.	Plate	Name
196292	24734	Panel Powerstat Brush
195621	24739	Panel Powerstat Dial
50587R		Panel Powerstat Dial Screw (3)
195622	24739	Panel Powerstat Knob with two 140454J
140454J		Panel Powerstat Knob Screw (2)
50761S		Panel Powerstat Screw (3)
701348		Panel Powerstat Screw Washer (3)
196032		Panel Switch (Line Breaker)
195910	24739	Panel Switch Name Plate (Power)
140497R	24739	Panel Switch Name Plate Screw (2)
140498R	24739	Panel Switch Screw (4)
195594	24739	Panel Switch (Tack)
796801	24739	Panel Switch (Tack) Indicator (off and on)
195909	24739	Panel Switch (Tack) Name Plate (Spot Seal)
140497R	24739	Panel Switch (Tack) Name Plate Screw (2)
196059	24741	Pick-up Coil with two 897580
196060	24741	Pick-up Coil Grounding Post
51125	24741	Pick-up Coil Grounding Post Screw (brass)
897580		Pick-up Coil Terminal (2)
195583	24743	Receptacle (foot switch)
51324S	24743	Receptacle (foot switch) Screw (2)
195604		Receptacle (fuse)
195581	24741	Receptacle (line input)
51324S	24741	Receptacle (line input) Screw (2)
195580		Receptacle (Motor)
140122S		Receptacle (Motor) Screw (2)
195595	24738	Rectifier Unit Safety Switch (Micro)
51605J	24738	Rectifier Unit Safety Switch Nut (for fastening Micro Switch to bracket)
195600	24738	Rectifier Unit Socket (2)
50672S		Rectifier Unit Socket Screw (2)
701679T		Rectifier Unit Socket Screw Lock Washer (2)
136358S		Rectifier Unit Socket Screw Washer (steel) (4)
701147		Rectifier Unit Socket Screw Washer (fiber) (4)
195597	24737	Rectifier Unit Transformer (Filament)
50782S		Rectifier Unit Transformer Screw (4)
701804T		Rectifier Unit Transformer Screw Lock Washer (4)
195452	24724	Rectifier Unit Tube (2)
		NOTE: Two additional No. 195452 are sent with each complete Singer Electronic Oscillator
195907	24738	Rectifier Unit Tube Cap with Lead (2)
1783S	24724	Rectifier Unit Tube Cap Nut (2)
701804T		Rectifier Unit Tube Cap Nut Lock Washer (2)
67592		Rectifier Unit Tube Cap Nut Washer
195587	24738	Relay (keying)
50639S		Relay (keying) Screw (4)
931202T		Relay (keying) Screw Lock Washer (4)
195585	24738	Relay (overload, D.C.)
50647S		Relay (overload, D.C.) Screw (2)
701679T		Relay (overload, D.C.) Screw Lock Washer (2)
195584	24738	Relay (plate contactor)
50647S		Relay (plate contactor) Screw (2)
701679S		Relay (plate contactor) Screw Lock Washer (2)
195586	24738	Relay (time delay)
50639S		Relay (time delay) Screw (2)
931202T		Relay (time delay) Screw Lock Washer (2)
195592	24724	Resistor (bleeder)
195908	24719	Resistor (bleeder) Connection (2)
51732S	24719	Resistor (bleeder) Connection Nut (brass) (2)
701348S	24719	Resistor (bleeder) Connection Nut Lock Washer (2)
50514S	24719	Resistor (bleeder) Screw (2)
1799S	24719	Resistor (bleeder) Screw Nut (2)
931202T	24719	Resistor (bleeder) Screw Nut Lock Washer (2)
195598	24737	Transformer (plate)

ELECTRICAL PARTS

SINGER ELECTRONIC OSCILLATOR NO. G46A

No.	Plate	Name
195445	24716	Cable with 195446
195446	24716	Cable Adaptor Plug (two to three wire)
195447	24736	Cable (Co-axial)
196396	24743	Choke (Filter)
196455		Choke (Filter) Mounting Strap (2)
50647S		Choke (Filter) Screw (4)
195608		Choke (Grid)
195608	24743	Choke (Plate)
196093	24743	Condenser (Filter)
140250S		Condenser (Filter) Screw (2)
701679T		Condenser (Filter) Screw Lock Washer (2)
1785		Condenser (Filter) Screw Nut (2)
994683	24742	Fusetron (plug, 6.25 Amp.)
196580	24743	Harness Clamp
196581		Harness Clamp
50782S	24743	Harness Clamp Screw (2)
701679S		Harness Clamp Screw Lock Washer (2)
1783S	24743	Harness Clamp Screw Nut (2)
196052	24740	Oscillator Cap (plate) with Lead (2)
50692S	24743	Oscillator Chassis Fastening Screw (3)
67193S		Oscillator Chassis Fastening Screw Lock Washer (3)
51601S		Oscillator Chassis Fastening Screw Nut (3)
701511S		Oscillator Chassis Fastening Screw Washer (3)
196056	24743	Oscillator Condenser Coupler (Grid)
196063		Oscillator Condenser (Grid) Shaft
196964	24743	Oscillator Condenser (Grid) with Lead
196055	24741	Oscillator Condenser (stand-off) (4)
50514	24741	Oscillator Condenser (stand-off) Mounting Screw (8)
701844		Oscillator Condenser (stand-off) Washer (8)
196053	24741	Oscillator Plate Tank Condenser
196054	24741	Oscillator Plate Tank Condenser Mounting Bracket (2)
195582	24743	Oscillator Receptacle (Amphenol) Co-axial Cable
140125J	24743	Oscillator Receptacle (Amphenol) Co-axial Cable Screw (4)
51761J		Oscillator Receptacle (Amphenol) Co-axial Cable Screw Nut (4)
196065		Oscillator Resistor (Grid) with Bracket
50514		Oscillator Resistor (Grid) Fastening Screw (2)
1799S		Oscillator Resistor (Grid) Fastening Screw Nut (2)
196158	24742	Oscillator Rotor Lock (Grid)
196158	24741	Oscillator Rotor Lock (Plate)
196091	24742	Oscillator Transformer (filament)
196454		Oscillator Transformer (filament) Mounting Strap (2)
50647S		Oscillator Transformer (filament) Screw (4)
196051	24740	Oscillator Tube (2)
		NOTE: Two additional No. 196051 are sent with each complete Singer Electronic Oscillator.
196159	24742	Oscillator Tube Socket (2)
50841J	24742	Oscillator Tube Socket Mounting Screw (4)
1799		Oscillator Tube Socket Mounting Screw Nut (4)
701844		Oscillator Tube Socket Mounting Screw Washer (4)
195460	24739	Panel Bulb (pilot light, 115V, 6 Watts) (2)
195603	24739	Panel Lens (pilot, amber) with Socket complete
195602	24739	Panel Lens (pilot, red) with Socket complete
196160	24739	Panel Milliammeter
195577	24741	Panel Milliammeter Condenser (by-pass)
51672S	24741	Panel Milliammeter Condenser Nut (4)
151060T		Panel Milliammeter Condenser Nut Lock Washer (4)
190091S		Panel Milliammeter Condenser Nut Washer (4)
195616	24741	Panel Powerstat
196292	24740	Panel Powerstat Brush
195621	24739	Panel Powerstat Dial

ELECTRICAL PARTS

No.	Plate	Name
50587R		Panel Powerstat Dial Screw (3)
195622	24739	Panel Powerstat Knob with two 140454J
140454J		Panel Powerstat Knob Screw (2)
140500S	24739	Panel Powerstat Screw (3)
701348		Panel Powerstat Screw Washer (3)
15155	24742	Panel Powerstat Screw Nut (3)
196458	24739	Panel Switch (Line Breaker)
195910	24739	Panel Switch Name Plate (Power)
140497R	24739	Panel Switch Name Plate Screw (2)
140498R	24739	Panel Switch Screw (4)
195594	24739	Panel Switch (Tack)
796801	24739	Panel Switch (Tack) Indicator (off and on)
195909	24739	Panel Switch (Tack) Name Plate (Spot Seal)
140497R	24739	Panel Switch (Tack) Name Plate Screw (2)
196059	24741	Pick-up Coil with two 897580
196060	24741	Pick-up Coil Grounding Post
51125	24741	Pick-up Coil Grounding Post Screw (brass)
897580		Pick-up Coil Terminal (2)
195583	24743	Receptacle (foot switch)
51324S	24743	Receptacle (foot switch) Screw (2)
196457	24742	Receptacle (fuse)
196453		Receptacle (fuse) Insulation (paper)
50771S	24742	Receptacle (fuse) Screw (2)
701804		Receptacle (fuse) Screw Lock Washer (2)
701719		Receptacle (fuse) Screw Washer (2)
195581	24741	Receptacle (line input)
51324S	24741	Receptacle (line input) Screw (2)
196452	24743	Receptacle (Motor)
51324S	24743	Receptacle (Motor) Screw (2)
195600	24742	Rectifier Unit Socket (2)
196410		Rectifier Unit Socket Mounting Plate
51239X		Rectifier Unit Socket Mounting Plate Screw (2)
701679S		Rectifier Unit Socket Mounting Plate Screw Lock Washer (2)
51522S		Rectifier Unit Socket Mounting Plate Screw Nut (2)
50678X	24742	Rectifier Unit Socket Screw (4)
701679T		Rectifier Unit Socket Screw Lock Washer (4)
51522S		Rectifier Unit Socket Screw Nut (4)
136358S		Rectifier Unit Socket Screw Washer (steel) (4)
701147		Rectifier Unit Socket Screw Washer (fiber) (4)
196090	24743	Rectifier Unit Transformer (Filament)
196454	24743	Rectifier Unit Transformer (Filament) Mounting Strap (2)
50647S	24743	Rectifier Unit Transformer Screw (4)
195452	24742	Rectifier Unit Tube (2)
		NOTE: Two additional No. 195452 are sent with each complete Singer Electronic Oscillator.
196622	24742	Rectifier Unit Tube Cap with Lead (2)
195587	24742	Relay (keying)
50639S		Relay (keying) Screw (4)
931202T		Relay (keying) Screw Lock Washer (4)
19639S	24742	Relay (overload, D.C.)
50934S		Relay (overload, D.C.) Screw (2)
701679T		Relay (overload, D.C.) Screw Lock Washer (2)
931131S		Relay (overload, D.C.) Screw Washer (2)
196459	24742	Relay (plate contactor)
50700S	24742	Relay (plate contactor) Screw (2)
701804T		Relay (plate contactor) Screw Lock Washer (2)
701719		Relay (plate contactor) Screw Washer (2)
196451	24740	Relay (time delay) Condenser (Filter)
50644S		Relay (time delay) Condenser (Filter) Screw (2)
701804S		Relay (time delay) Condenser (Filter) Screw Lock Washer (2)
196449	24740	Relay (time delay) Tube
196448	24740	Relay (time delay) Tube Socket

ELECTRICAL PARTS

No.	Plate	Name
50514		Relay (time delay) Tube Socket Screw (2)
931202T		Relay (time delay) Tube Socket Screw Lock Washer (2)
67230		Relay (time delay) Tube Socket Screw Washer (2)
195592	24743	Resistor (bleeder)
195908		Resistor (bleeder) Connection (2)
701850		Resistor (bleeder) Connection Nut Lock Washer (2)
50514S		Resistor (bleeder) Screw (2)
1799S		Resistor (bleeder) Screw Nut (2)
931202T		Resistor (bleeder) Screw Nut Lock Washer (2)
196089	24740	Transformer (Plate)
196456	24740	Transformer (Plate) Mounting Strap (2)
50761S	24740	Transformer (Plate) Screw (4)
196450	24741	Switch (door interlock)
51605J	24741	Switch (door interlock) Nut (for fastening switch to bracket)

CABLE NO. 196635
(FROM OSCILLATOR TO TRANSMITTER)

No.	Plate	Name
191407	24745	Cable (only)
191406		Cable (complete, Nos. 191407 and 898780)
898780	24745	Cable Clamp with 50771
50771	24745	Cable Clamp Screw
196636	24745	Cable Plug
196635	24745	Cable 191406 with 196636 (from Oscillator to Transmitter)

FOOT TREADLE MICRO SWITCH
NO. 196645

No.	Plate	Name
196601		Foot Treadle Cord complete, Nos. 195567, 965841 and two 196495
196602	24746	Foot Treadle Cord Cable Clamp
50640R	24746	Foot Treadle Cord Cable Clamp Fastening Screw
51601R	24746	Foot Treadle Cord Cable Clamp Fastening Screw Nut
931202R	24746	Foot Treadle Cord Cable Clamp Fastening Screw Washer
190070	24746	Foot Treadle Cord Grommet
965841	24746	Foot Treadle Cord Lead
196495	24746	Foot Treadle Cord Lead Terminal (2)
195567	24746	Foot Treadle Cord Plug
196599		Foot Treadle Micro Switch
196593	24746	Foot Treadle Micro Switch Extension Frame
196600		Foot Treadle Micro Switch Insulation (paper)
140744		Foot Treadle Micro Switch Mounting Screw
196597	24746	Foot Treadle Micro Switch Saddle
196598	24746	Foot Treadle Micro Switch Saddle Adjusting Spring
51128R	24746	Foot Treadle Micro Switch Saddle Adjusting Spring Screw
51601R	24746	Foot Treadle Micro Switch Saddle Pivot Nut
140745J	24746	Foot Treadle Micro Switch Saddle Pivot Screw
701497R	24746	Foot Treadle Micro Switch Saddle Pivot Washer (2)
196595	24746	Foot Treadle Return Spring
196596	24746	Foot Treadle Return Spring Retaining Plate
50671R	24746	Foot Treadle Return Spring Retaining Plate Screw
196445	24746	Foot Treadle Micro Switch complete, Nos. 50640R, 50671R, 51128R, 140744, 140745J, 190070, 196593, 196595, 196596, 196597, 196598, 196599, 196600, 196601, 196602, 931202R and two each 51601R and 701497R

NOTE: Foot Treadle Micro Switch complete, No. 196445 is included in Stand No. 601241.

KNEE LIFTER PARTS

No.	Plate	Name
169081	24747	Chain, length 14 1/4 in. with 56865
56865	24732	Chain Hook (small)
62164	24747	Chain Idler Pulley (2)
128815	24747	Chain Idler Pulley Bracket with two wood screws 1 in. No. 12 (2)
1064R	24747	Chain Idler Screw (2)
150036	24747	Chain Idler complete, Nos. 1064R, 62164 and 128815 (2)
7124	24747	Rock Shaft
7539	24747	Rock Shaft Hanger (back) with two wood screws 1 in. No. 10
20093	24747	Rock Shaft Hanger (front) with two wood screws 1 in. No. 10
6335	24747	Rock Shaft Knee Arm with 1509E
6336	24747	Rock Shaft Knee Arm complete, Nos. 2766, 2767 and 6335
2766	24747	Rock Shaft Knee Arm Hub with 356C
356C	24747	Rock Shaft Knee Arm Hub Set Screw
1509E	24747	Rock Shaft Knee Arm Lock Nut
2767	24747	Rock Shaft Knee Plate with 356C
150668	24747	Rock Shaft Knee Plate Pad (rubber)
356C	24747	Rock Shaft Knee Plate Set Screw
6337	24747	Rock Shaft Lifting Bracket with two 356C
34592	24747	Rock Shaft Lifting Bracket Hook
356C	24747	Rock Shaft Lifting Bracket Hook Set Screw
356C	24747	Rock Shaft Lifting Bracket Set Screw
2770	24747	Rock Shaft Stop Dog with 140219C
140219C	24747	Rock Shaft Stop Dog Set Screw
169082	24747	Rock Shaft complete, Nos. 2770, 6336, 6337, 7124, 7539, 20093 and 34592
169083	24747	Knee Lifter complete, Nos. 150668, 169081, 169082 and two 150036

NOTE: Knee Lifter complete, No. 169083 is furnished only when specified on order.

OIL RESERVOIR

No.	Plate	Name
169047	24732	Oil Reservoir, with four wood screws 1 1/2 in. No. 6 F.H.

TUNING UNIT

No.	Plate	Name
169042	24731	Tuning Unit Dial
195606	24735	Tuning Unit Knob
195607	24735	Tuning Unit Knob Flange
140444	24735	Tuning Unit Knob Flange Screw (2)
195605	24735	Tuning Unit Knob 195606 with 195607 and two 140444
50514J	24735	Tuning Unit Knob Screw
169046	24735	Tuning Unit Shaft Coupling with two 140490C
140490C	24735	Tuning Unit Shaft Coupling Set Screw (2)
196193	24735	Tuning Unit complete, Nos. 50514J, 169042, 169046 and 195605

24704 - 1/3

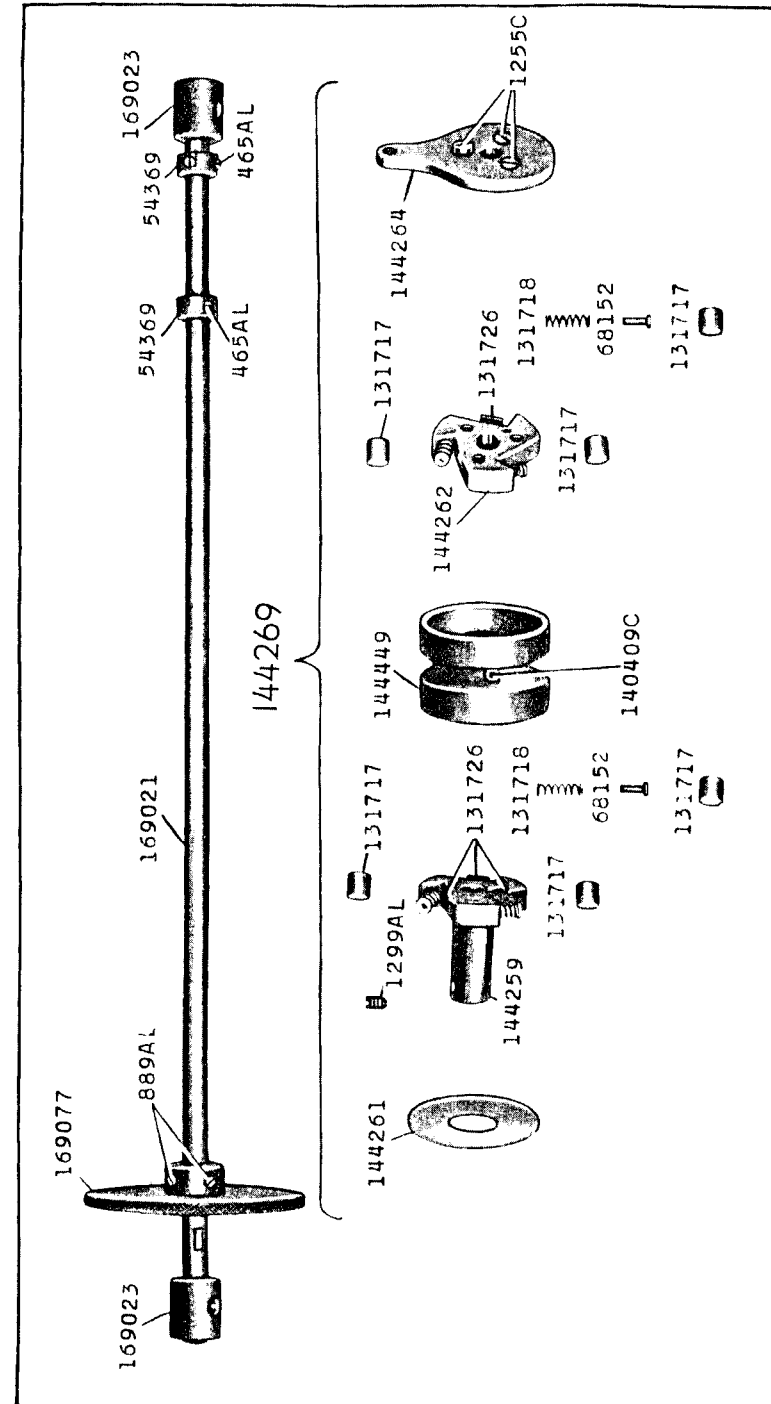

24710 - 2/3

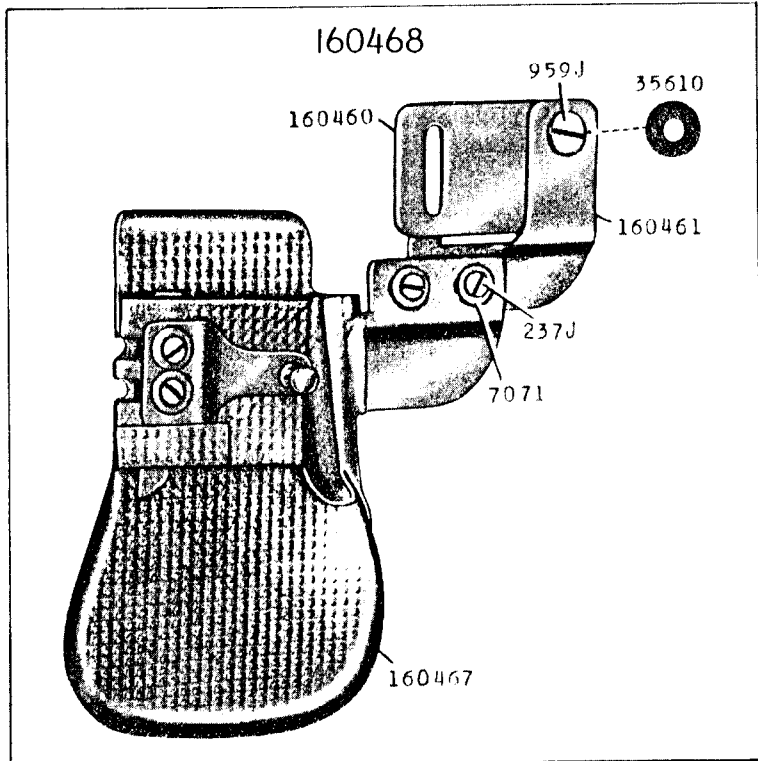

160466

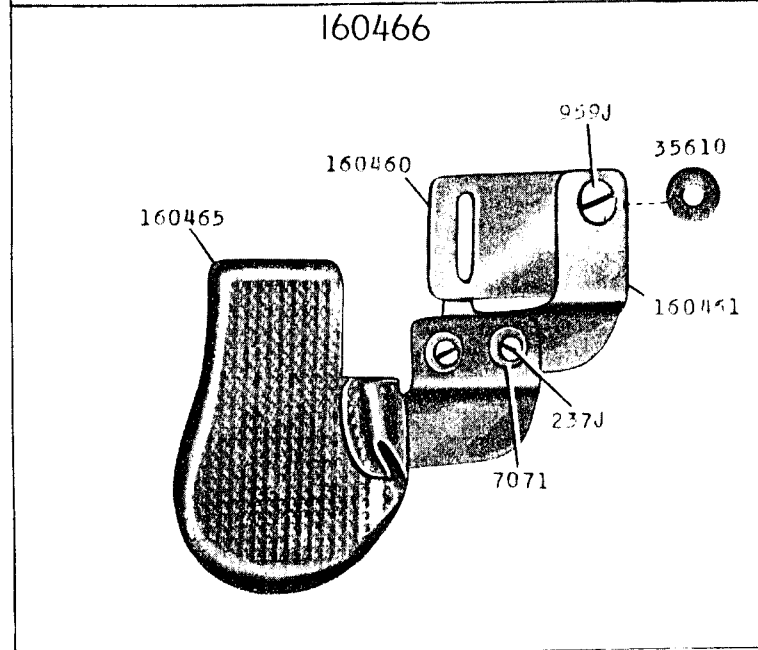

24711 - 2/3

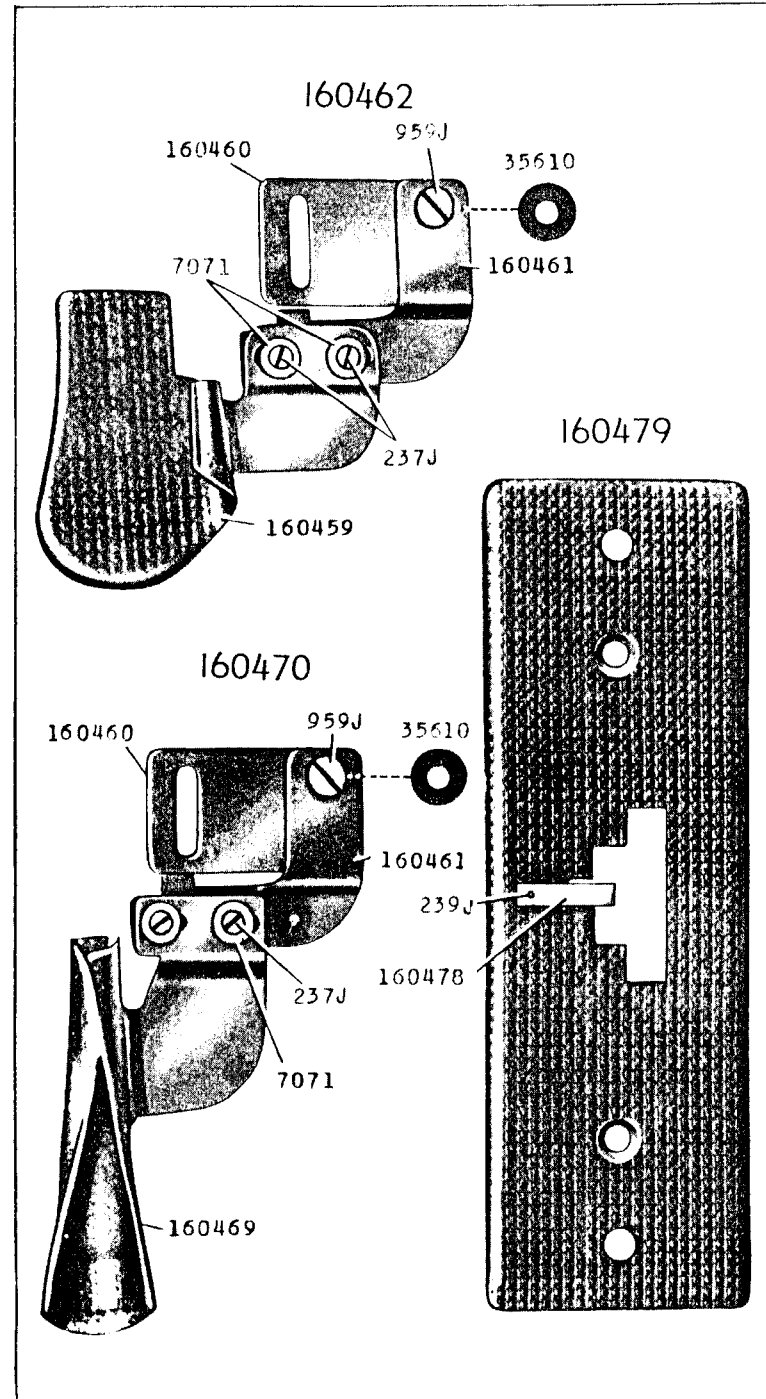

24713 - 1/3

195453

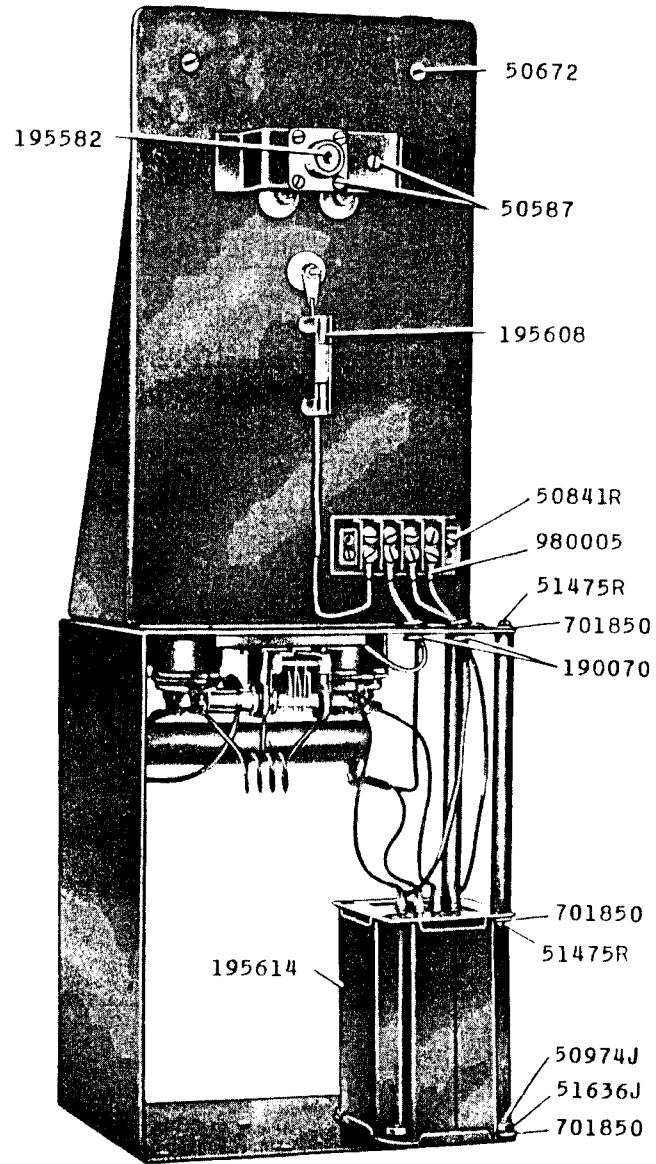

24714 - 1/3

195458

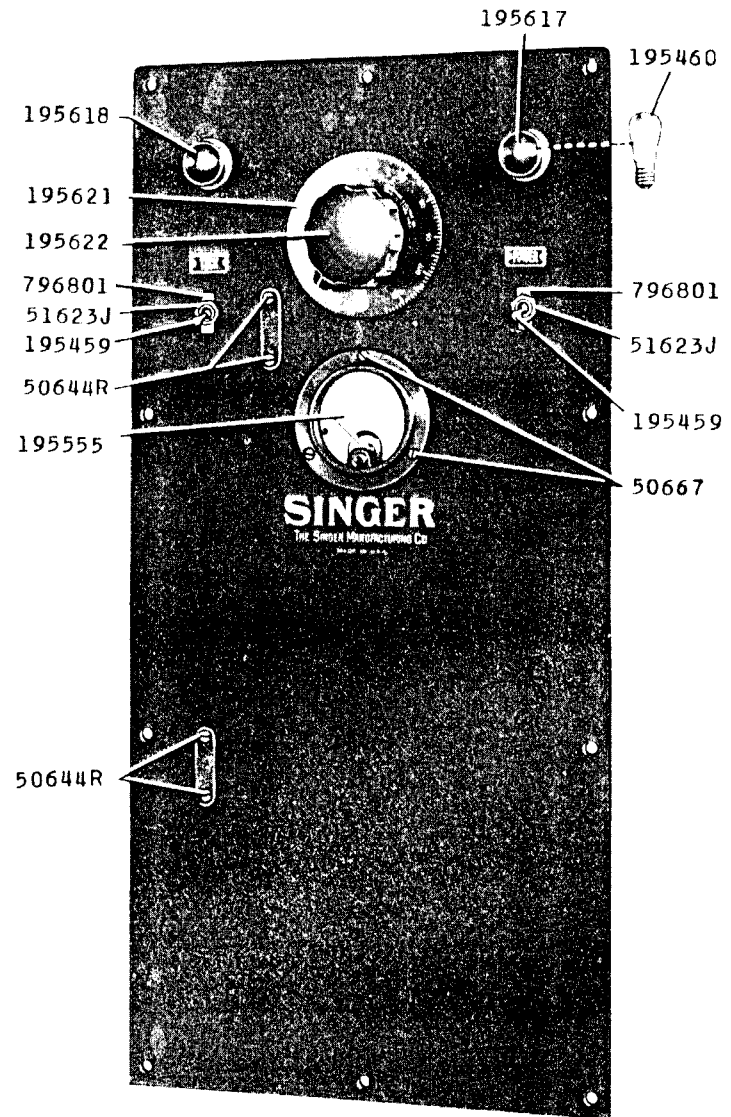

24716 - 1/2

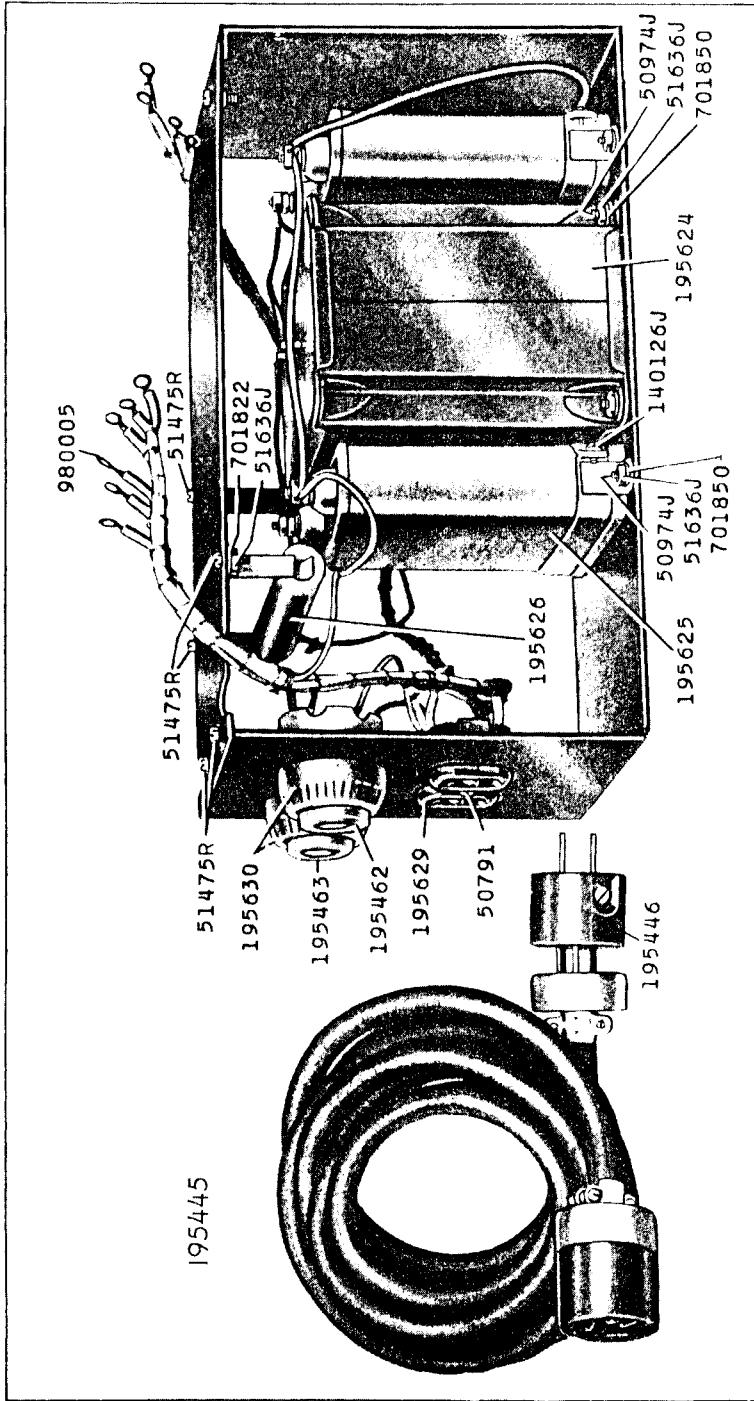

24719

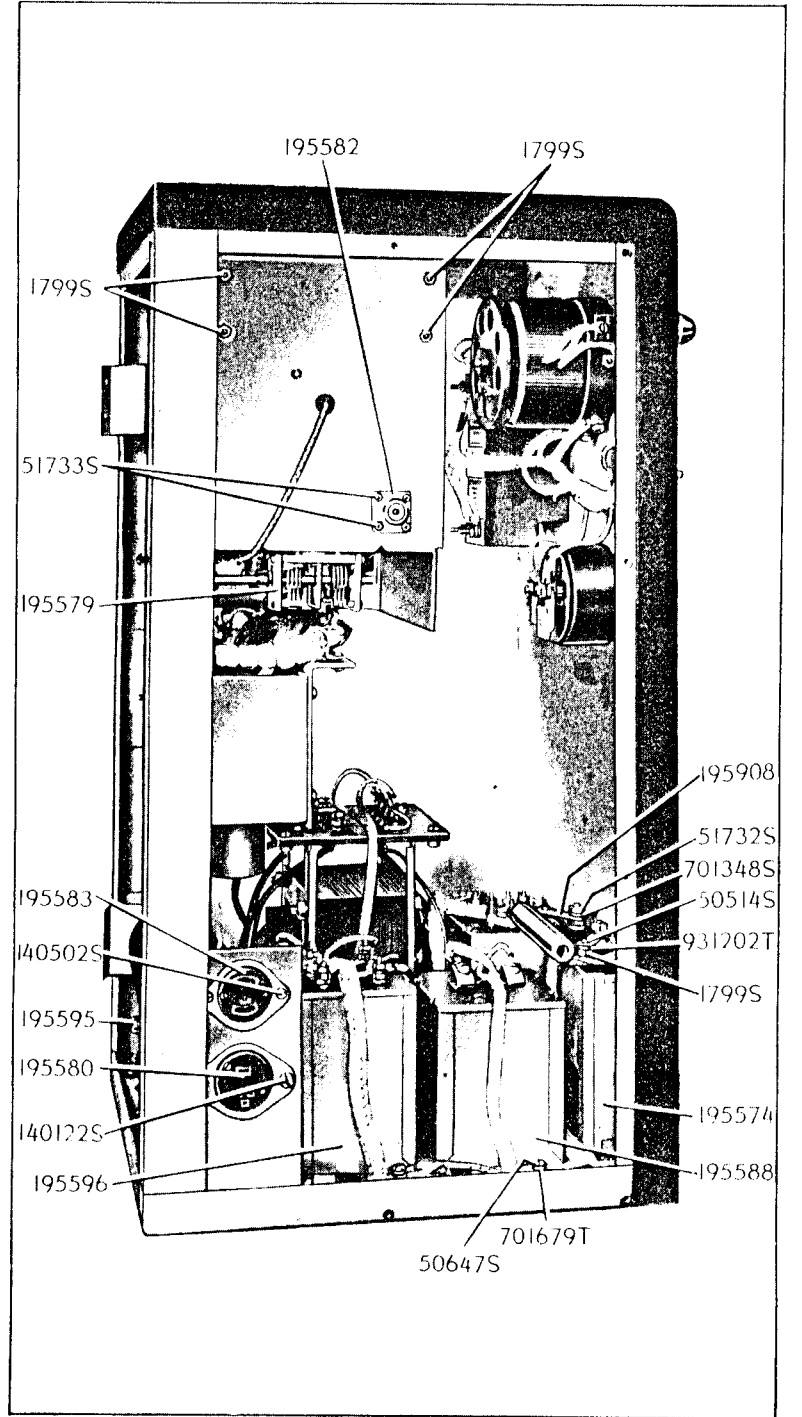

24721

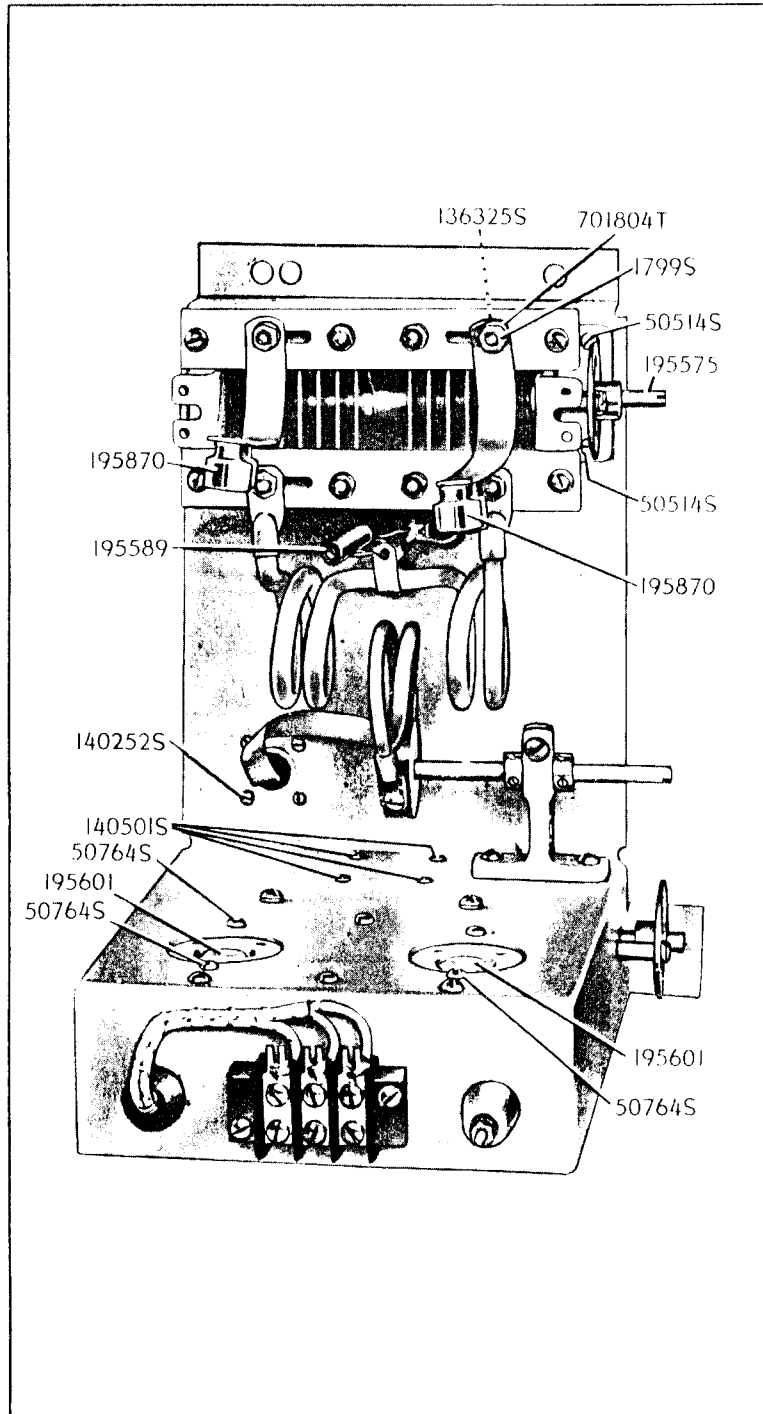

24722

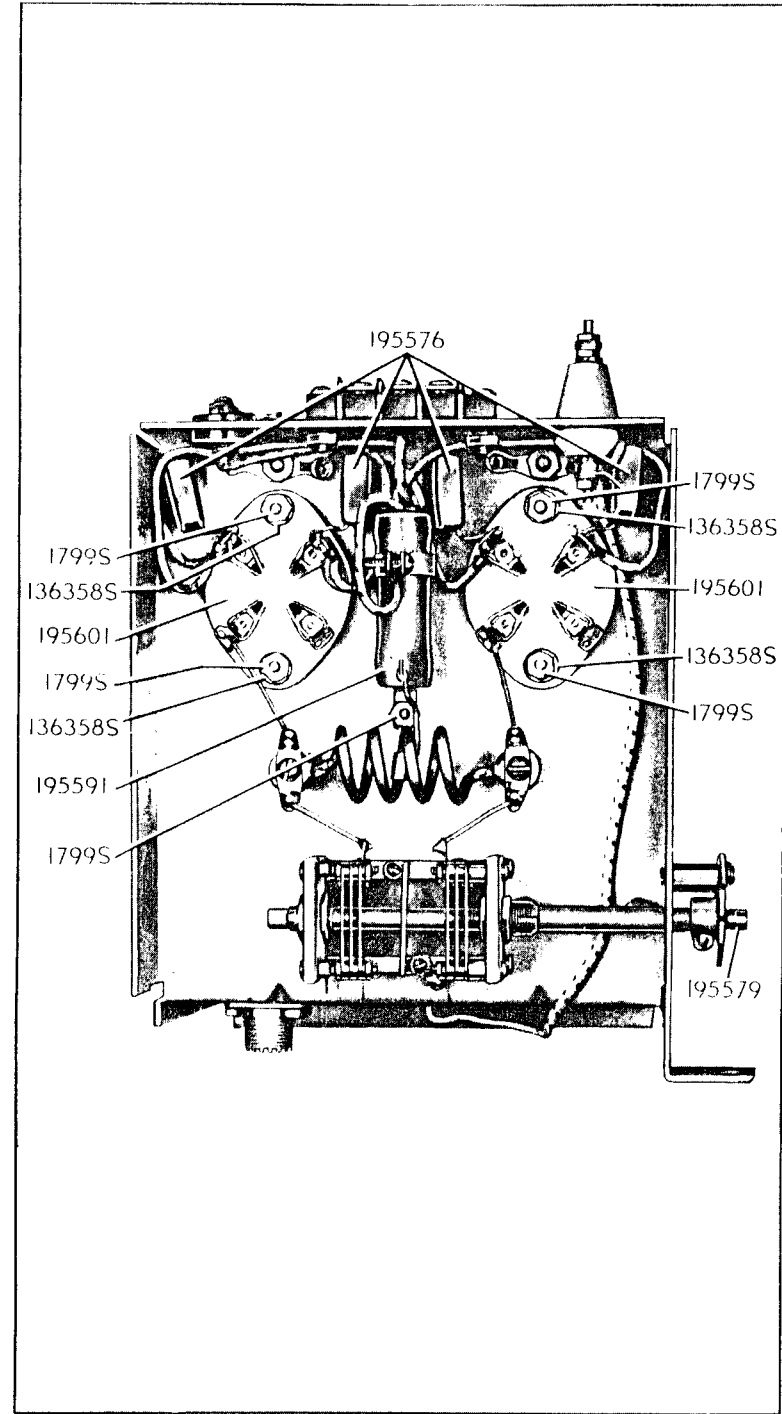

24723

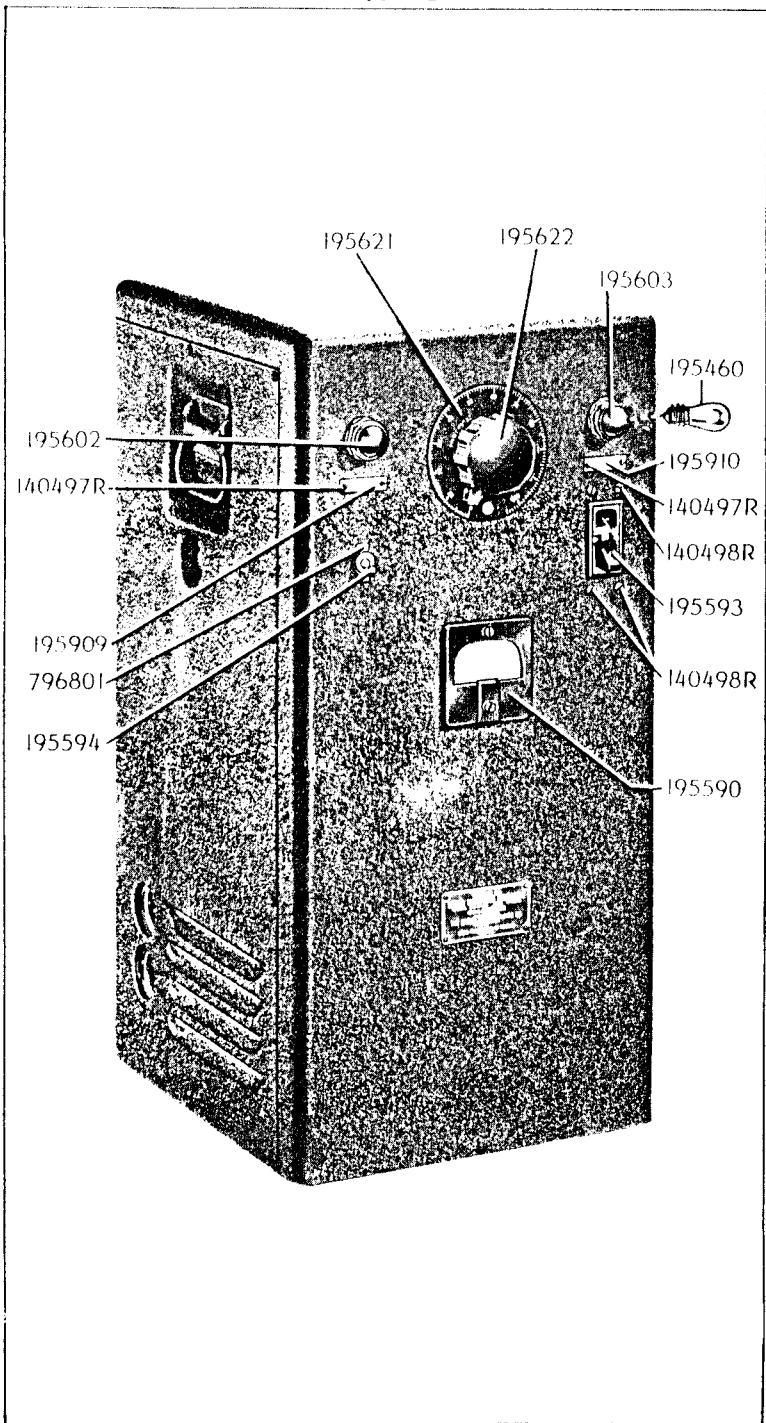

24724

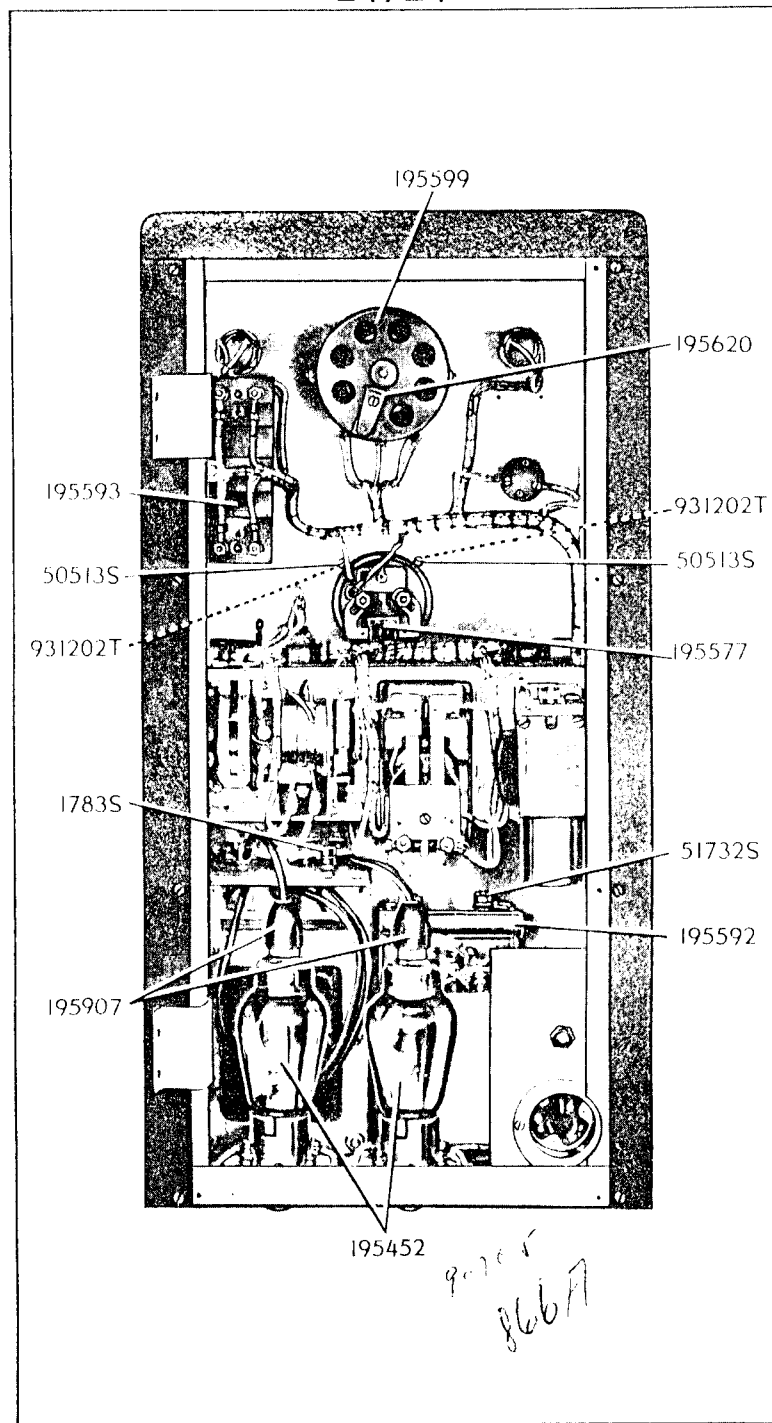

24727-1/3

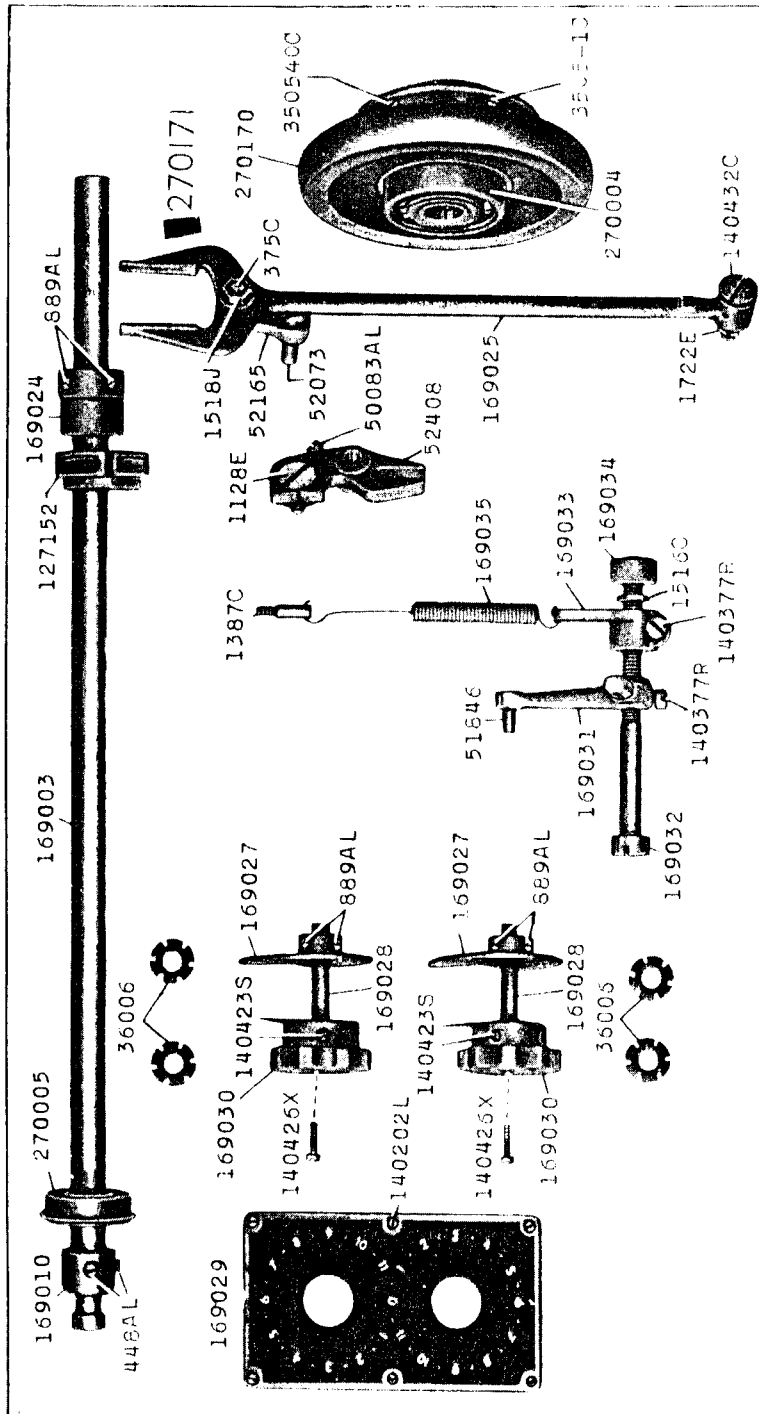

24728.2/3

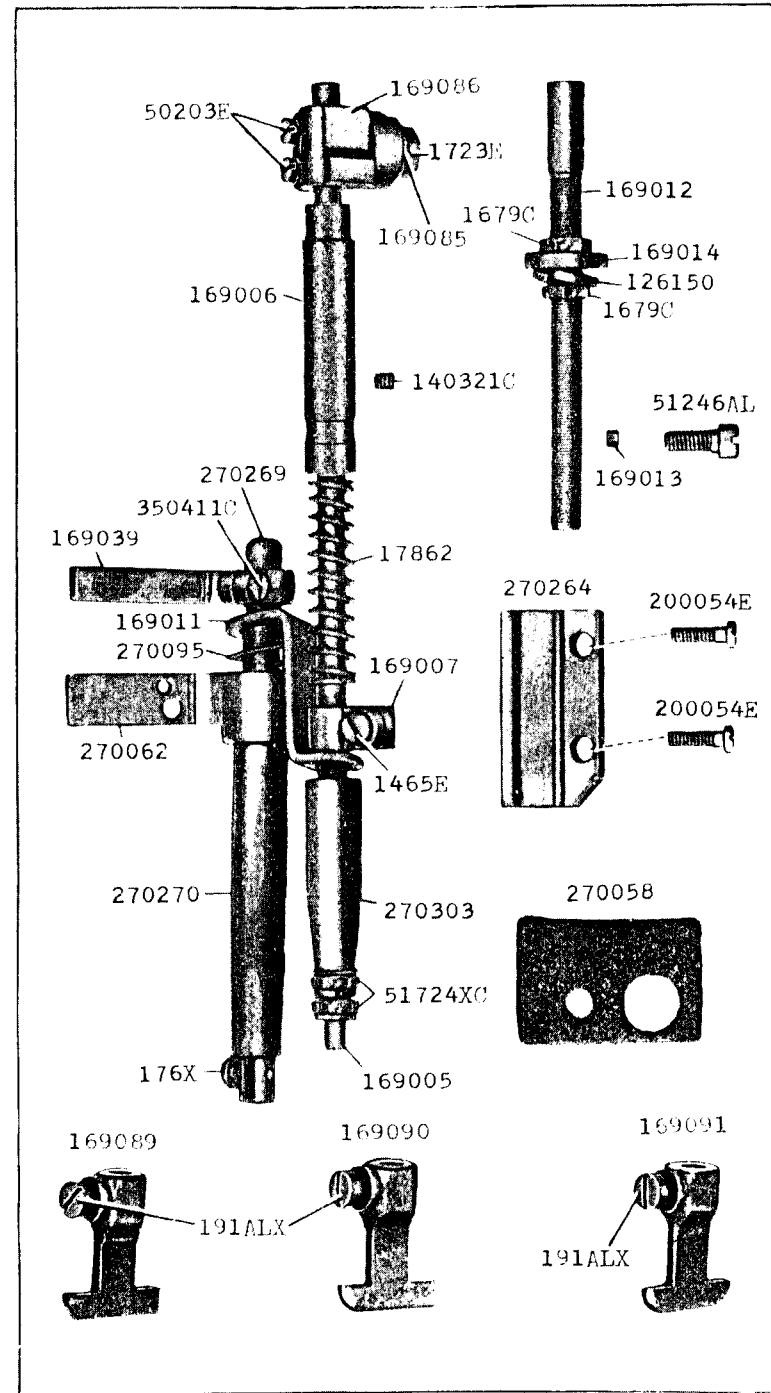

24729-1/2

169050R

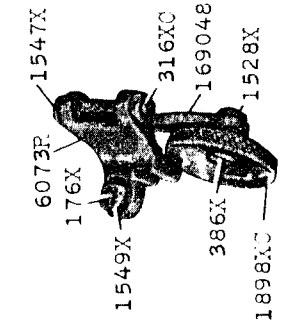

12267R

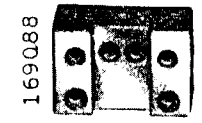
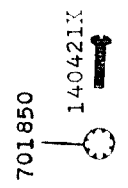
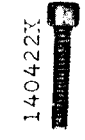
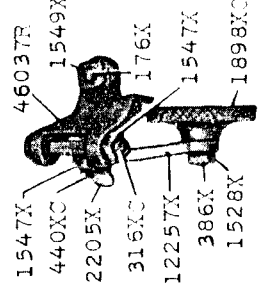

169074

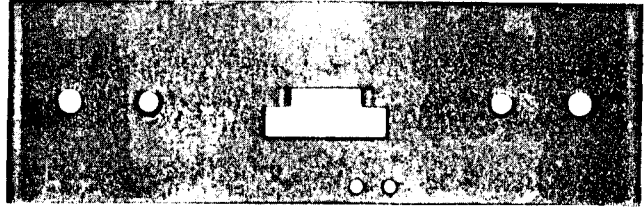

169072

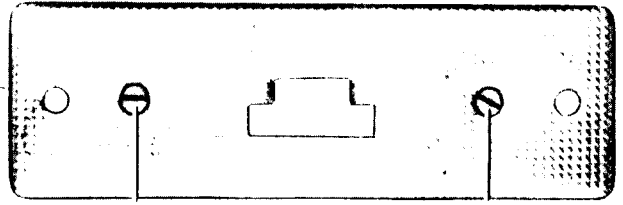

691F

691F

24730-1/3

169041

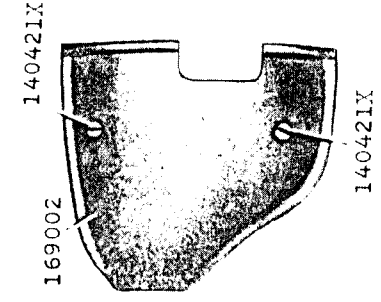
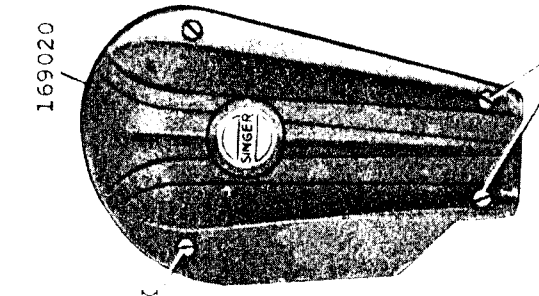
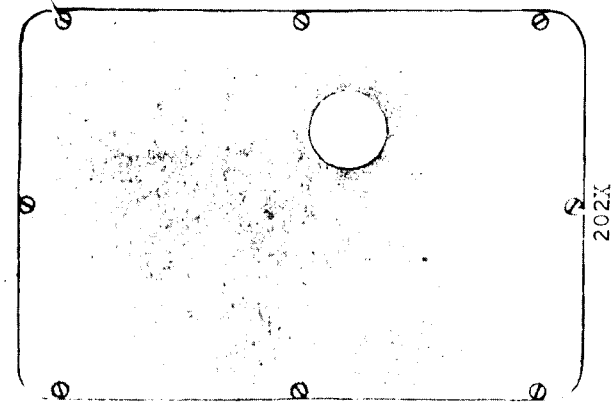

140421X

140421X

24731-1/2

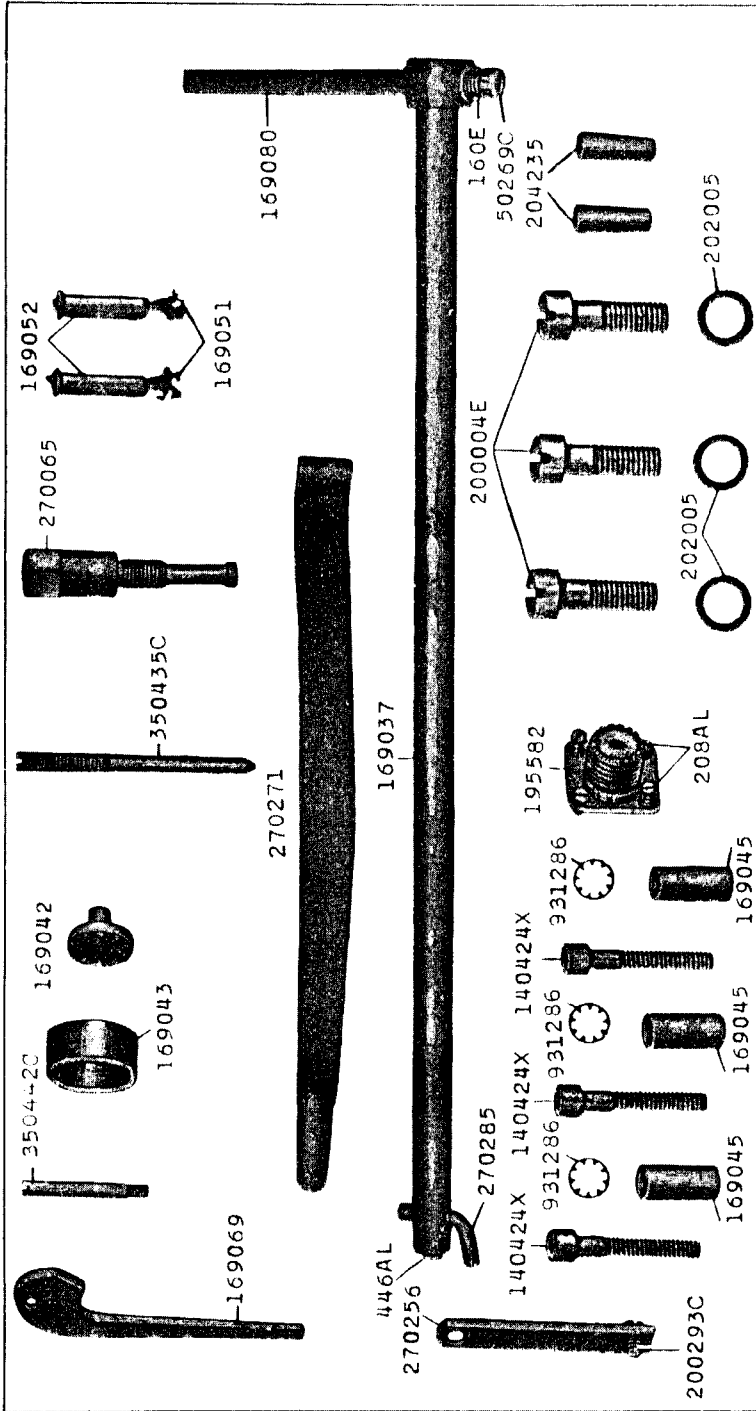

24732-1/3

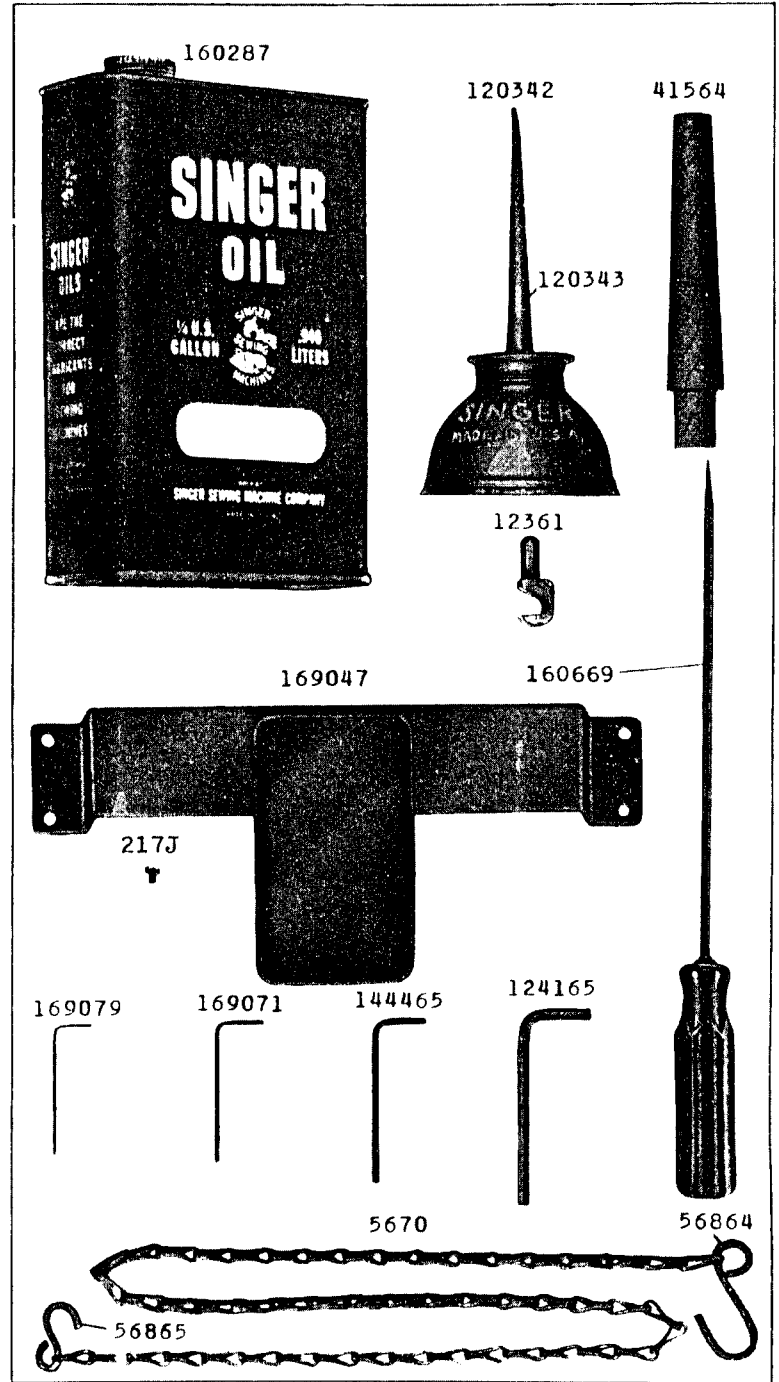

24733-1/3

195453

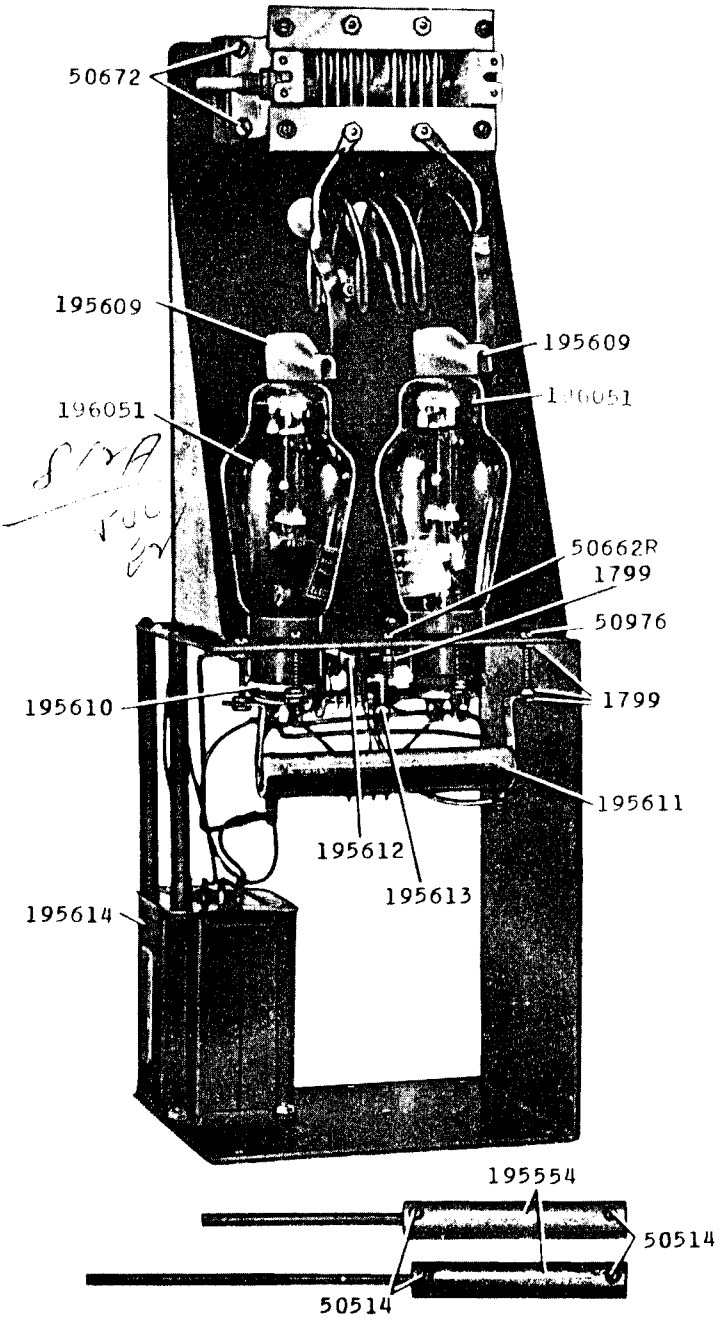

24734-1/3

195458

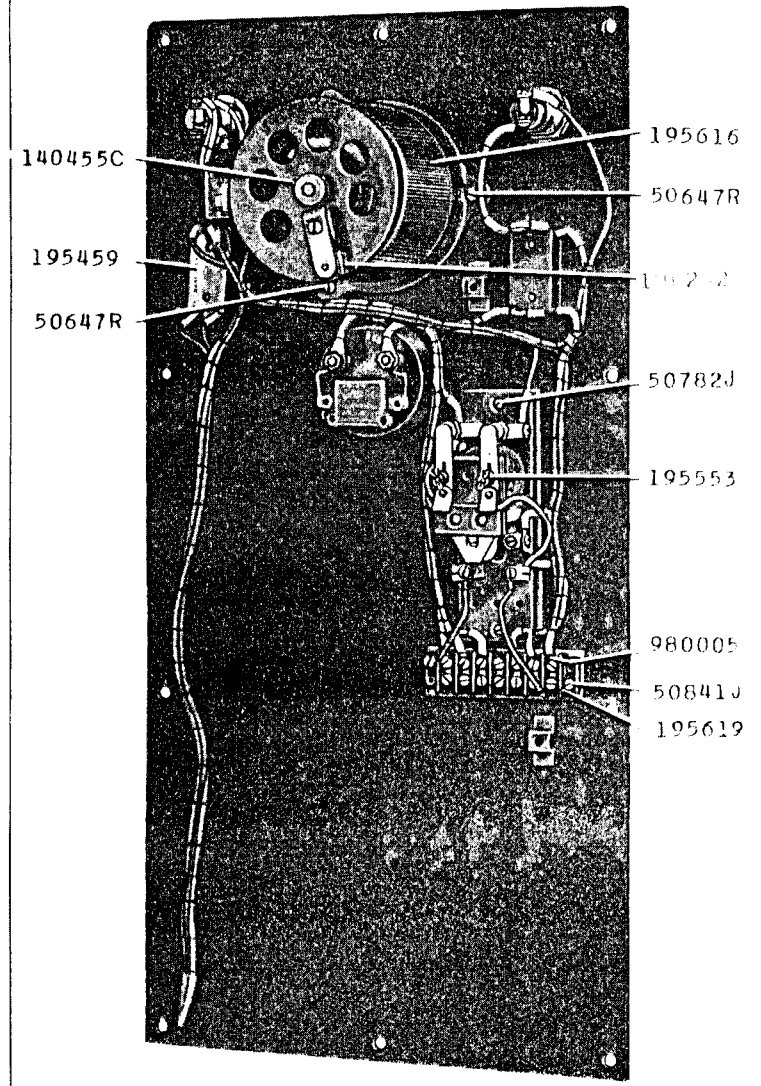

24735-1/2

195454

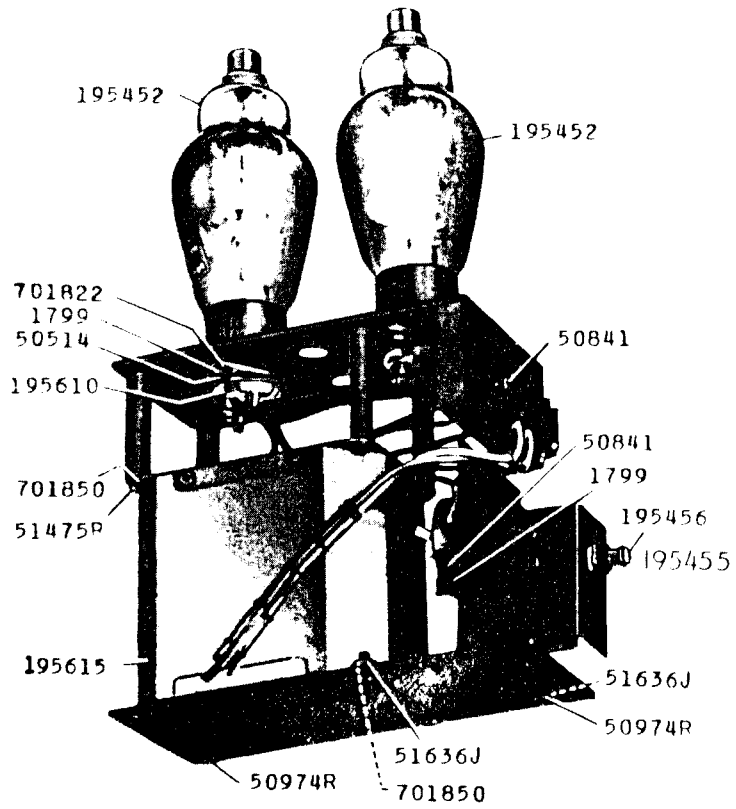

196193

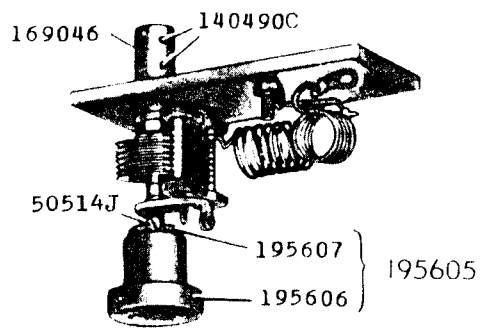

24736-1/2

195447

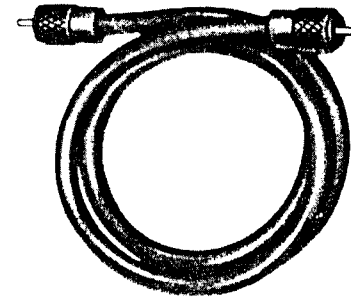

195623

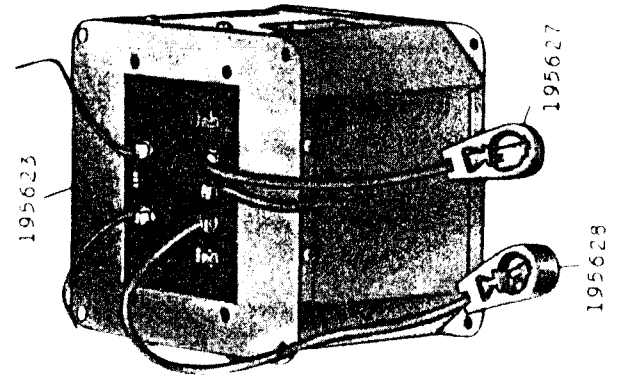

24737

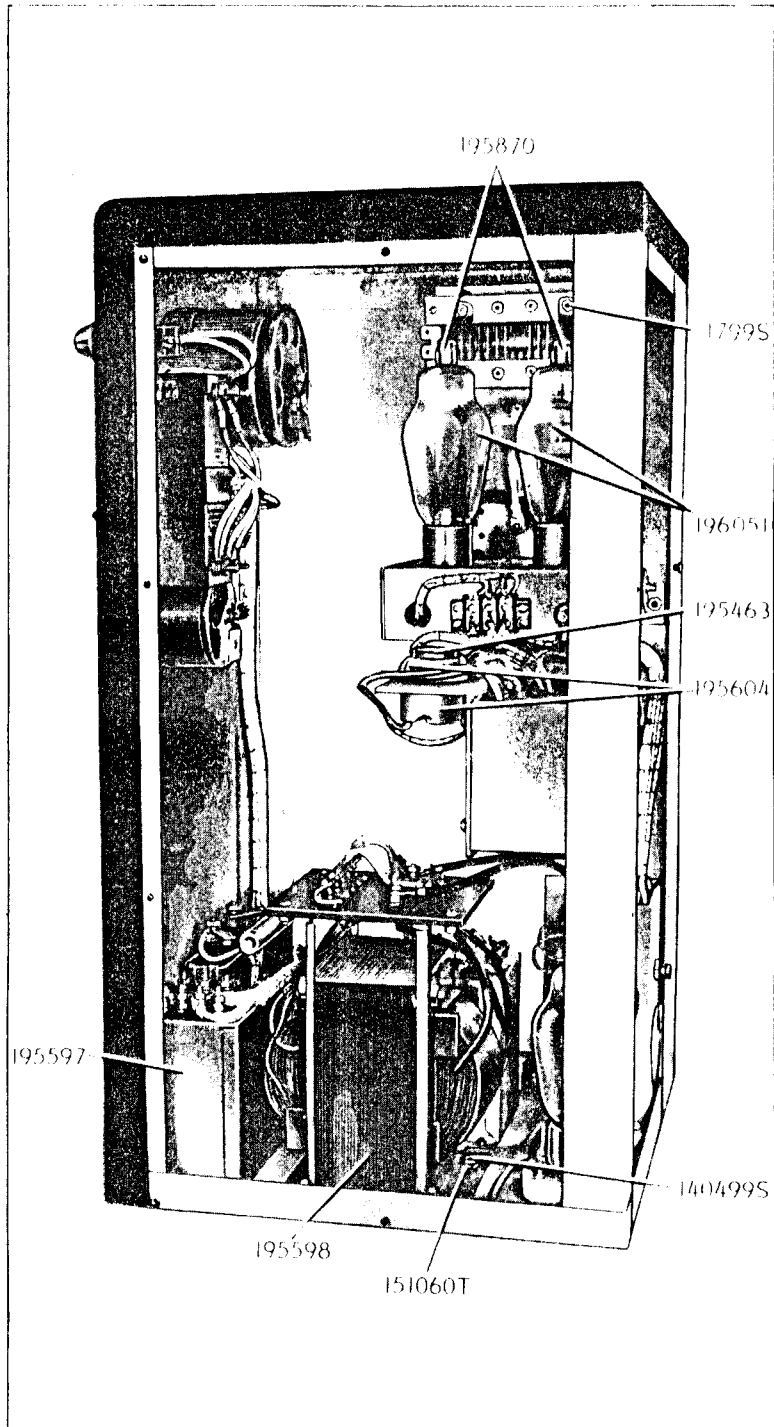

24738

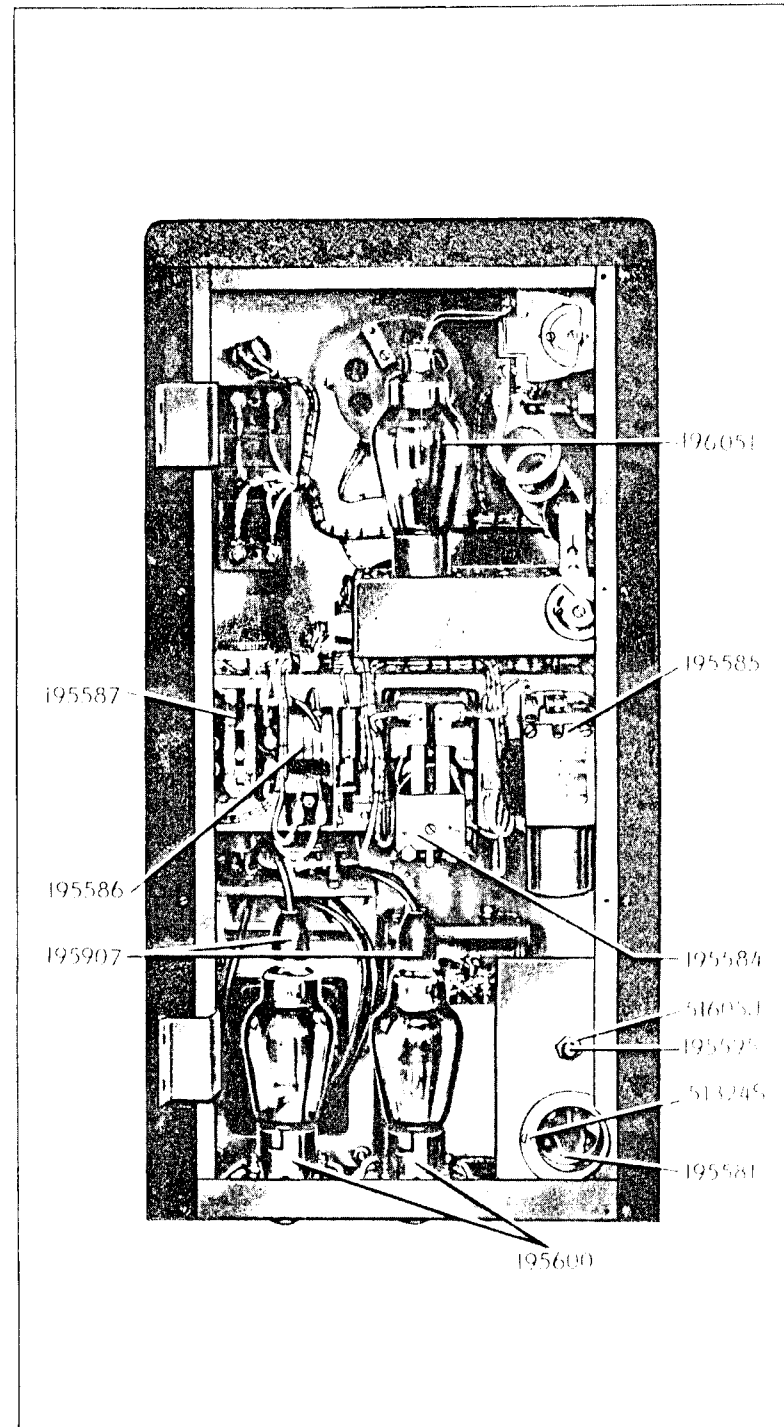

24739

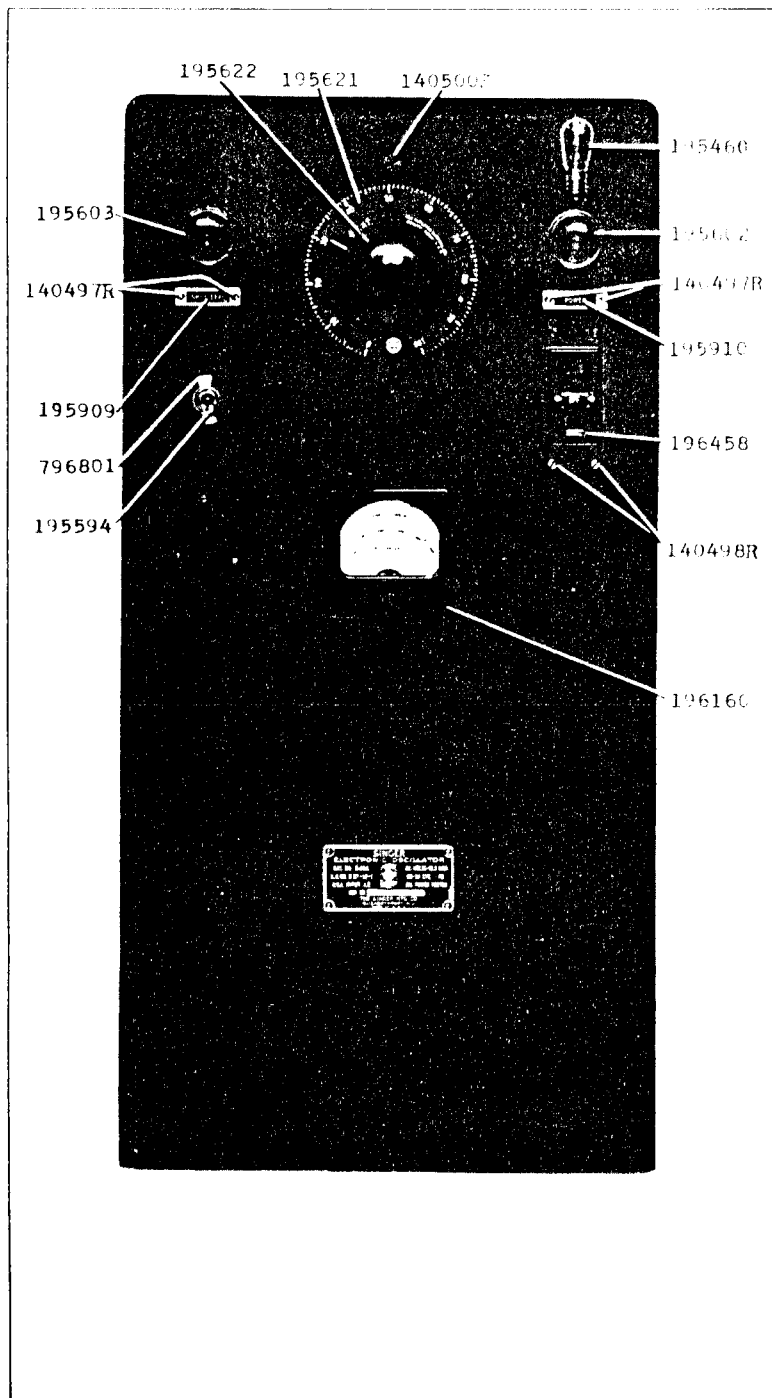

24740

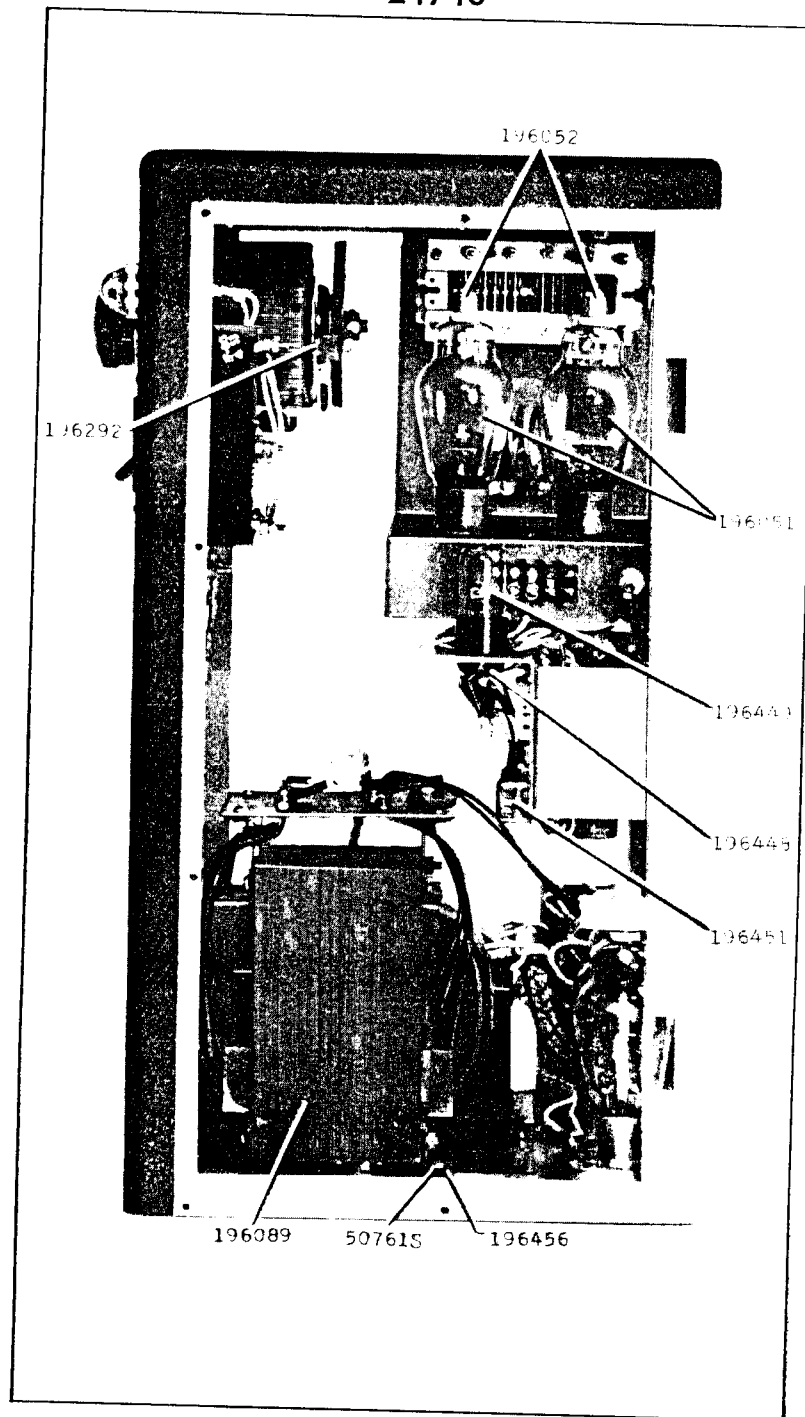

24741

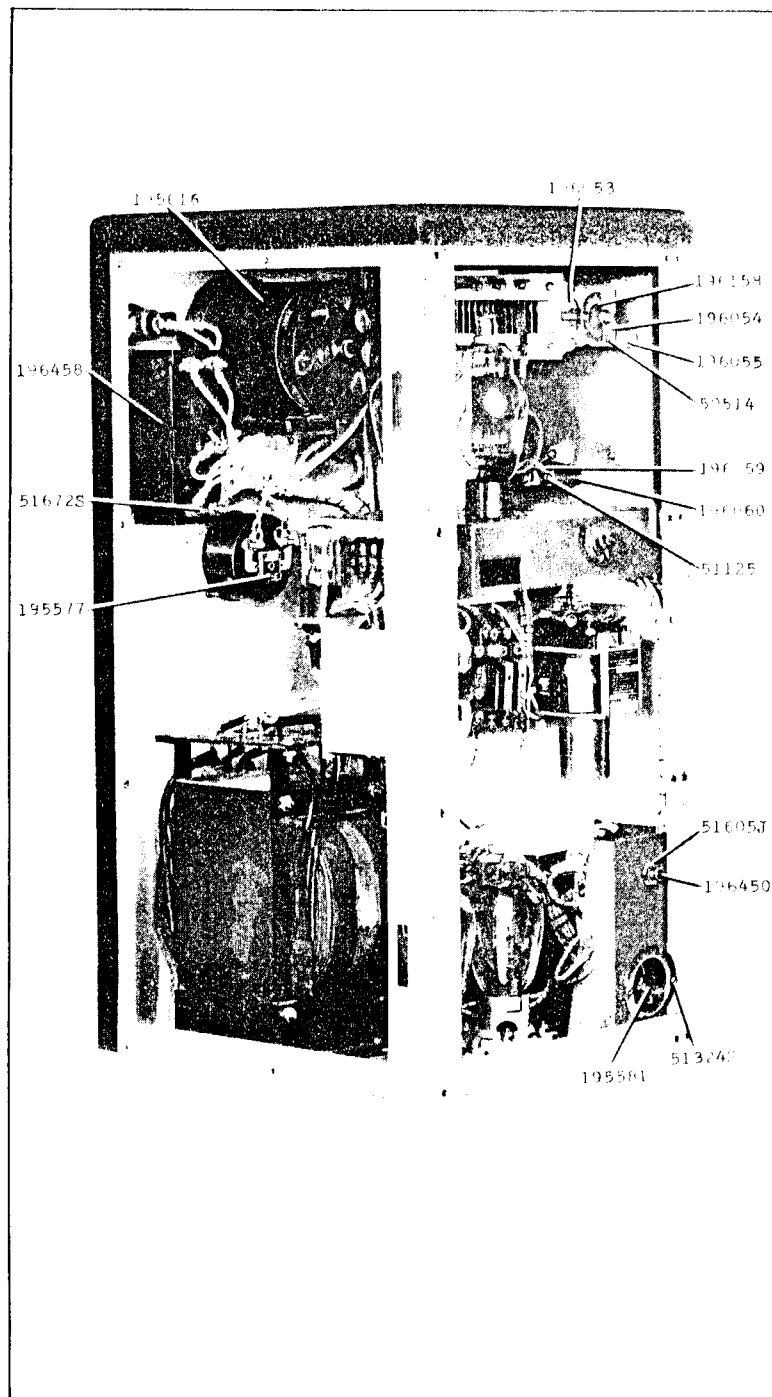

24742

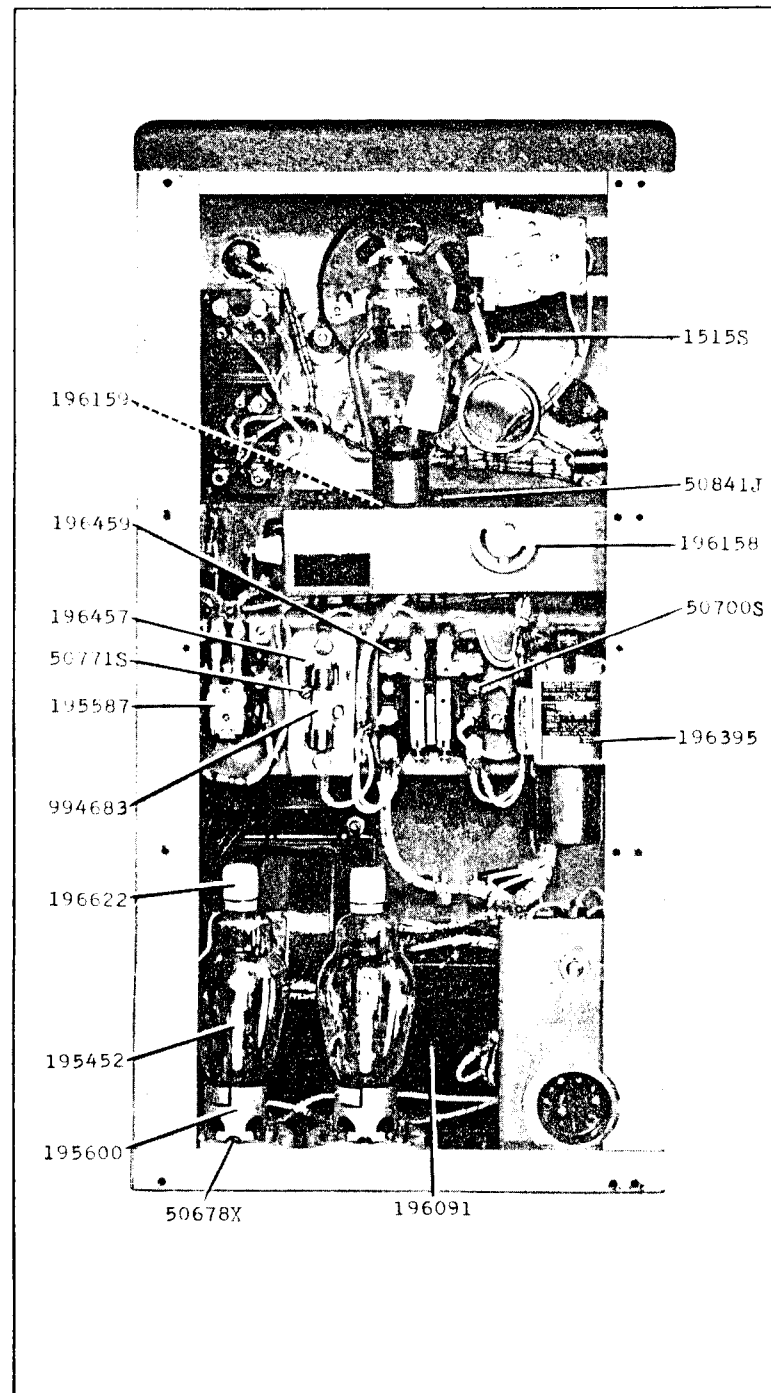

24743

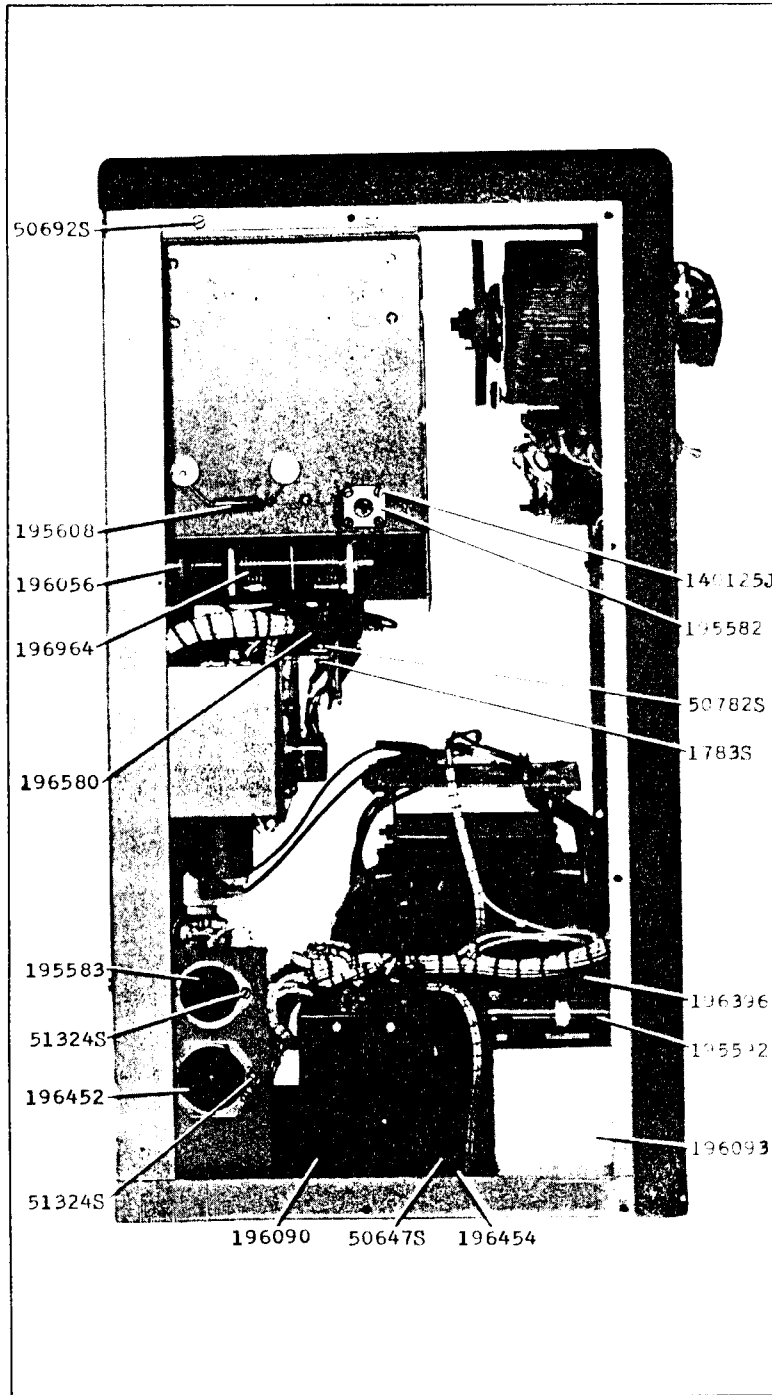

24744-1/3

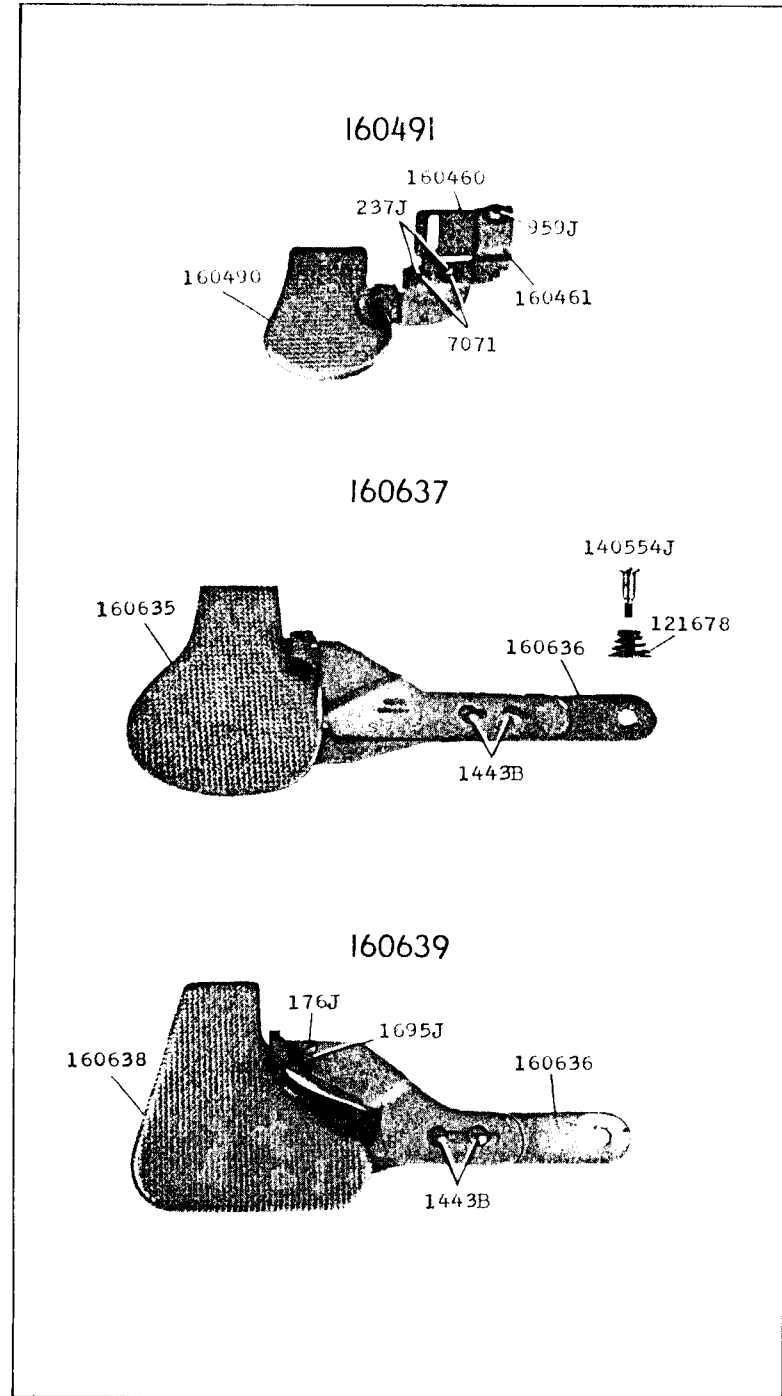

24745-1/3

196635

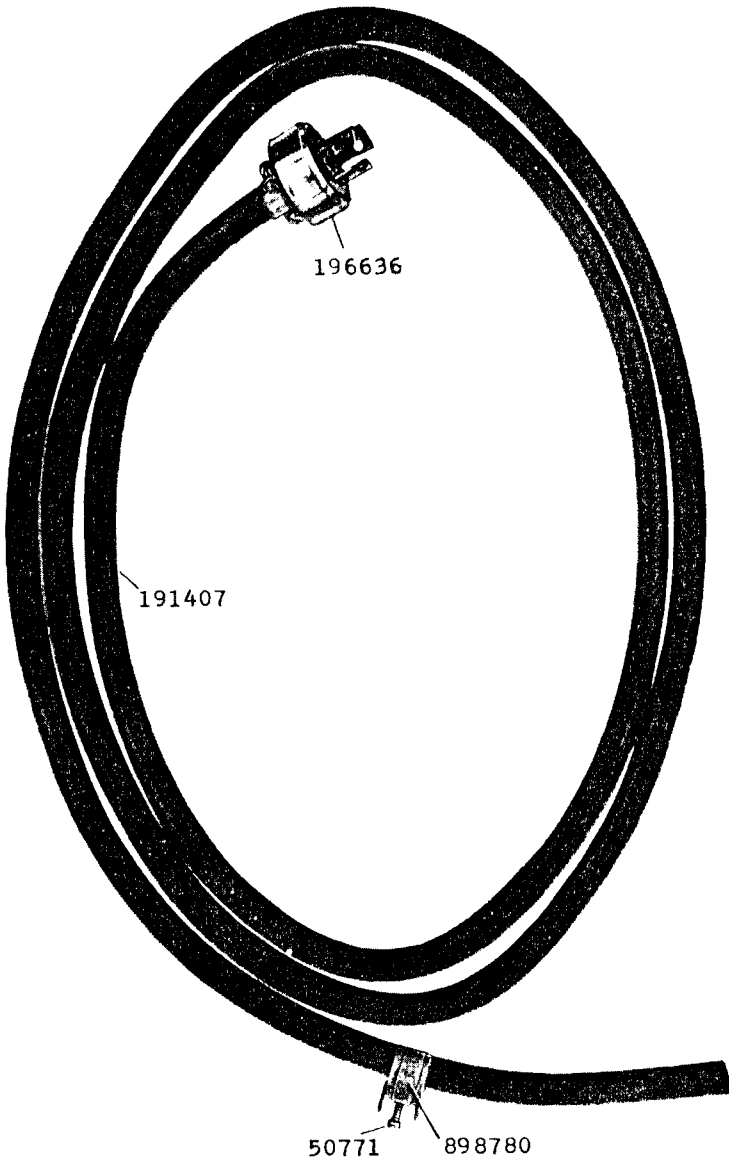

24746-1/3

196445

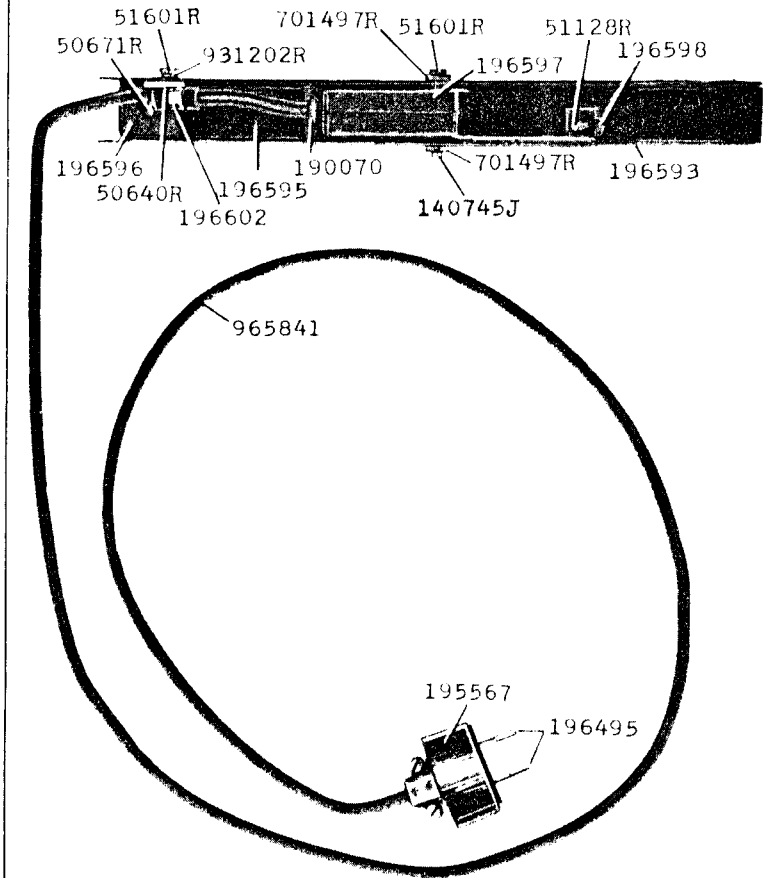

24747-1/3

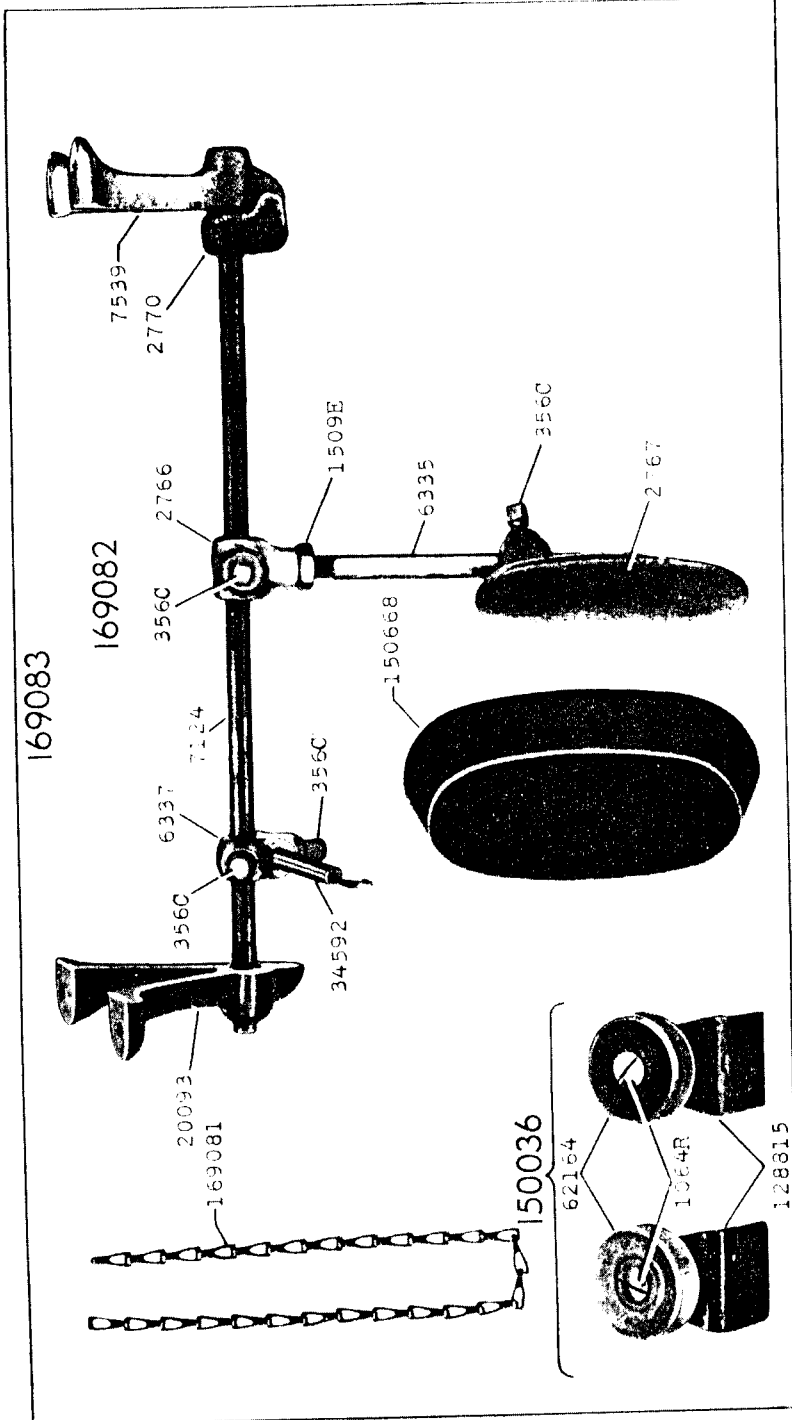

24748-1/2

160464

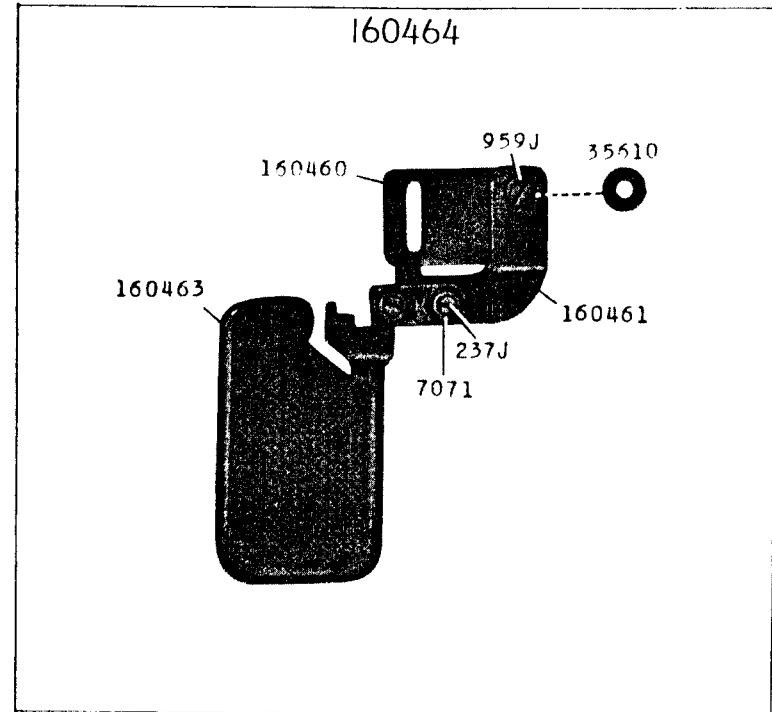

160472

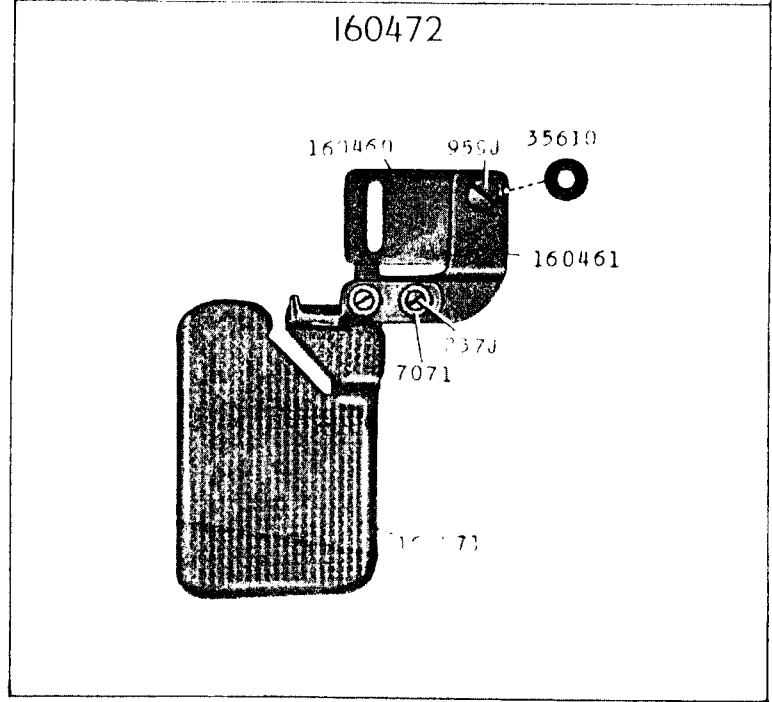

24749-2/3

160475

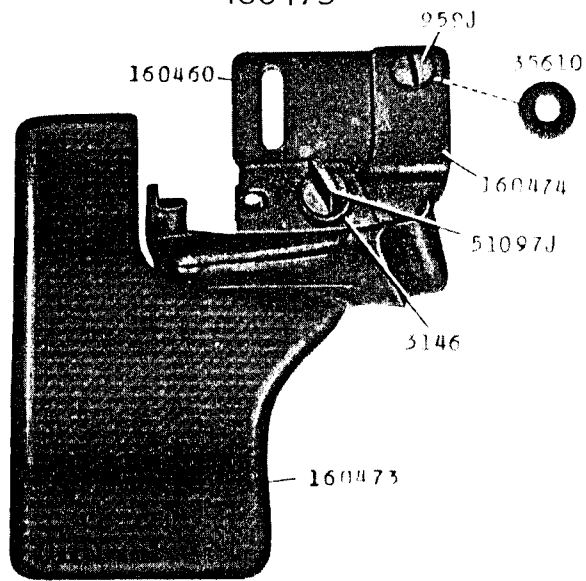

160477

