

Form 18511

July, 1931

Printed in U. S. A.

LIST OF PARTS



MACHINES
Nos. 24-70 and 24-71

** A TRADE MARK OF

THE SINGER MANUFACTURING COMPANY

INSTRUCTIONS FOR OILING

To ensure easy running and prevent unnecessary wear of the parts which are in movable contact, the machine requires oiling and when in continuous use, "TYPE B" or "TYPE D" OIL, sold only by Singer Sewing Machine Company, should be applied at least twice each day to all oil holes marked "OIL", as instructed in Form 18479
"TYPE D" OIL is stainless.

COPYRIGHT, U. S. A., 1922, 1930 and 1931
BY THE SINGER MANUFACTURING Co.
ALL RIGHTS RESERVED FOR ALL COUNTRIES

INDEX

	PAGE
ACCESSORIES.....	18
FOOT LIFTER PARTS.....	19
HAND ATTACHMENT PARTS.....	17
KNEE LIFTER PARTS.....	19
MACHINE No. 24-70.....	7
" " 24-71.....	12
NUMERICAL LIST OF PARTS.....	23
NEEDLE BAR STOP DEVICE PARTS.....	18
TAPE HOLDER.....	20
THREAD UNWINDER.....	20

INSTRUCTIONS FOR ORDERING

In ordering from this list, use **ONLY** the part NUMBER in the **FIRST** column.

The number stamped on a Sewing Machine part is in every case the number of the single part only.

Every combination of parts sent out as such has its specific number, which, although not stamped on the parts, must be used when ordering the combination.

Each number always indicates the **SAME PART** in whatever list it appears, or for whatever machine.

The letters after some of the numbers indicate the style of finish only, as follows:

- A—Hardened, Polished, Nickel Plated and Buffed
- B—Polished, Nickel Plated and Buffed
- C—Hardened Only
- D—Polished Only
- E—Soft, Not Polished
- F—Hardened and Polished
- H—Blued
- J—Nickel Plated Only
- K—Hardened and Nickel Plated
- L—Brass Plated
- M—Oxidized
- N—Japanned, Dull
- P—Japanned, Bright
- R—Merlized
- T—Copper Plated
- T. A.—Hardened, Polished, Copper and Nickel Plated and Buffed
- T. B.—Copper and Nickel Plated and Polished
- T. J.—Copper and Nickel Plated Only
- T. K.—Hardened, Copper and Nickel Plated
- T. M.—Copper Plated and Oxidized
- T. L.—Copper and Brass Plated
- U—Zinc Plated
- V—Silver Plated
- W—Polished and Nickel Plated
- Y—Black Nickel Plated Only
- Z—Chromium Plated
- Z. B.—Polished, Nickel Plated, Buffed and Chromium Plated
- Z. J.—Nickel and Chromium Plated

These letters **MUST BE USED** when they appear in the list; and **AFTER** the number **as** in the list.

In this series:

- 1 to 1500 and 50001 to 51500 are Screw Numbers
- 1501 to 1800 and 51501 to 51800 are Nut Numbers
- 1801 to 2000 and 51801 to 52000 are Roller Numbers
- 2001 to 50000 and 52001 and upward are numbers of Machine Parts

The figures in the second column refer only to the plates, illustrating the parts, and are **NOT TO BE USED** in ordering.

Parts marked with an asterisk (*) are furnished only when repairs are made at factory.

When ordering parts which differ as to **Gauge** (the distance between seams) the Gauge, as well as the **Number must be given** on order.

LIST OF PARTS COMPLETE FOR

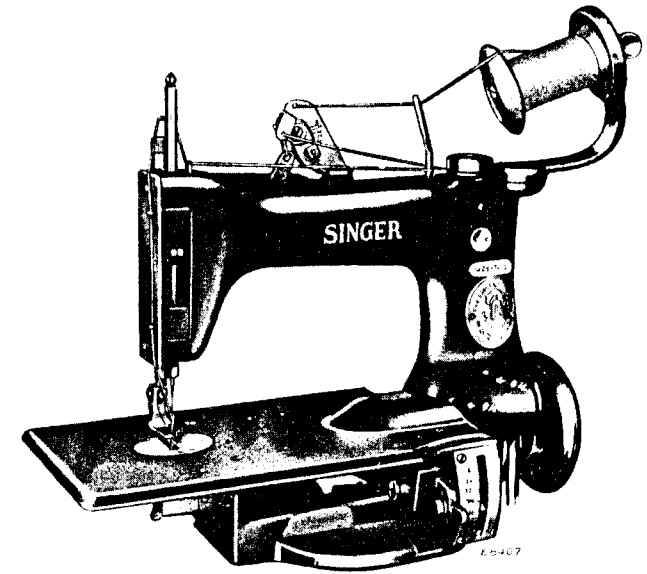

MACHINE No. 24-70

FOR STITCHING IN LABELS. HAS AUTOMATIC TENSION AND GRADUATED THREAD MEASURING DEVICE. THE GRADUATIONS ARE MADE TO AGREE WITH THOSE ON THE FEED REGULATOR INDEX PLATE. BY SETTING THE POINTERS ON THE MEASURING DEVICE AND THE FEED REGULATOR INDEX PLATE ON THE SAME FIGURE, THE EXACT AMOUNT OF THREAD REQUIRED FOR EACH STITCH WILL BE PULLED OFF. A KNIFE IS ATTACHED TO THE LOOPER AND AT THE COMPLETION OF THE OPERATION, THE TURNING OF THE BALANCE WHEEL IN THE REVERSE DIRECTION CUTS THE THREAD CLOSE TO THE MATERIAL. SPEED 2500.

NO.	PLATE	NAME
*34357	—	Arm, upper and lower (solid) with 130D and 22348.....
34589	6861	Arm Rock Shaft.....
32034	6857	" " " Crank (back) with 1259c and 1439c.....

PARTS FOR MACHINE No. 24-70

NO.	PLATE	NAME
1439c	6957	Arm Rock Shaft Crank (back) Position Screw.....
1259c	6857	Arm Rock Shaft Crank (back) Set Screw.....
34116	6857	" " " " (front) with two 1259c.....
1259c	6857	Arm Rock Shaft Crank (front) Set Screw.....
34186	6861	" Rotary Shaft with 1019c.....
199d	6859	" " " " Screw.....
32026	6860	Balance Wheel, 2 in. pulley.....
34086	4222	Cloth Plate with three 1602E.....
1602E	6858	" " Bushing.....
1104F	6859	" " Screw (large).....
219F	6859	" " " (small).....
34433	6861	Connecting Rod with 34434 and two 171E.....
*34434	—	" " Cap.....
171E	6859	" " " " Screw.....
1139c	6859	" " " " Hinge Screw.....
1520J	6858	" " " " " Nut.....
34311	6860	Face Plate with two 2827.....
337D	6859	" " " " Screw.....
2827	6858	" " " " Thread Guard with 8505.....
8505	6858	" " " " " Rivet.....
34088	4224	Feed Bar with 207c.....
22339	4224	" " " " Hinge Pin.....
207c	4224	" " " " " Set Screw.....
9578	6855	" " " " " Dog, 15 teeth (16 teeth to the inch).....
190D	6859	Feed Dog Screw.....
34187	6858	" Eccentric with two 1259c.....
34090	4224	" " " " Collar with 452c.....
452c	4224	" " " " " Set Screw.....
1259c	6857	" " " " " Set Screw.....
34091	4224	" " " " " Sleeve.....
34092	4224	" Forked Connection.....
378c	4224	" " " " " Hinge Screw.....
1520J	6858	" " " " " " Nut.....
1832	4224	" " " " " Roller with 1085c.....
1085c	4224	Feed Forked Connection Roller Screw Stud.....
34189	6858	Feed Lifting Eccentric with two 1259c.....
34093	4224	" " " " " Connection.....
1259c	6857	" " " " " Set Screw.....
34094	4225	" Regulator.....
34095	4225	" " " " Crank with 230F and 34096.....
34096	4225	" " " " " Pin.....
230F	4225	" " " " " Set Screw.....
1215E	4225	" " " " " Hinge Screw.....

PARTS FOR MACHINE No. 24-70

NO.	PLATE	NAME
34097	4225	Feed Regulator Indicator.....
34211	4225	" " " " Hinge Pin.....
34098	4225	" " " " " Plate.....
335D	4225	" " " " " Screw.....
1083c	4225	" " " " Locking Screw.....
34099	4225	" " " " " Washer.....
34100	4225	" " " " " Rock Shaft.....
34101	—	Feed Rock Shaft complete, Nos. 34100 and 34102.....
22348	6862	Feed Rock Shaft Bracket.....
130D	6859	" " " " " Screw.....
34102	4225	" " " " " Crank with 157R.....
157R	4225	" " " " " Clamping Screw.....
307c	4225	" " " " " Screw Center.....
56814	—	" " " " " " 307c with 1513J.....
1513J	4225	Feed Rock Shaft Screw Center Nut.....
35131	6860	Guide.....
286D	6859	" " " " " Thumb Screw.....
34600	6855	Looper with 34601.....
22349	4229	" " " " " Gate.....
1105E	4229	" " " " " Hinge Screw.....
22350	4229	" " " " " Spring.....
1019c	4229	" " " " " Set Screw.....
*34601	—	" " " " " Thread Cutting Knife.....
34418	6855	" " " " " Washer.....
34134	4237	Needle Bar with 22456.....
34170	4229	" " " " " Connecting Link with two 1313E.....
1313E	4229	Needle Bar Connecting Link Adjusting Screw.....
9570	4229	Needle Bar Connecting Stud with 207E.....
207E	4224	" " " " " " Clamping Screw.....
1629c	4229	Needle Clamping Nut.....
34103	4229	Presser Bar.....
34104	4229	" " " " " Guide Bracket with 223E.....
223E	4229	" " " " " " Adjusting Screw.....
34105	4229	Presser Bar Guide Bracket Guide.....
457c	4229	" " " " " " " Set Screw.....
999F	4229	" " " " " " " Set Screw.....
38540	4229	" " " " " " Lifter.....
50293E	6859	Presser Bar Lifter Hinge Screw.....
1521J	6858	" " " " " " " Nut.....
9534	4229	" " " " " " Spring.....
22405	4229	" " " " " " Washer.....

NO.	PLATE	NAME
34602	6855	Presser Foot with 34603 and 50470J.....
34603	6855	" " Spring Guide.....
50470J	6855	" " " " Screw.....
185H	6859	" " " " Screw.....
1121J	4229	Pressure Regulating Thumb Screw.....
34599	6860	Pulley and Thread Nipper Rod Eccentric, 2½ in. diam.
1167E	4224	Pulley and Thread Nipper Rod Eccentric Screw.....
34137	6862	Spool Bracket with 1009c.....
2049	6858	" " Dowel Pin.....
1008D	6859	" " Screw.....
19066	4222	" Spindle.....
1009c	6859	" " Set Screw.....
19067	4222	" Thread Guiding Disc.....
691A	6859	" " " " Screw.....
34169	4237	Thread Controller Post with 22429.....
460c	4237	" " " " Set Screw.....
22429	4237	" " Spring.....
34171	4237	" Eyelet (double).....
34604	6856	" Indicator and Thread Guide.....
34606	—	" " " " " " 34604 with 418D, 1562J, 23258, 34605, 43808, 50222D and two each 1735H and 29939..
50222D	6859	Thread Indicator and Thread Guide Screw
1735H	6858	" " " " " " " "
		Nut.....
23258	6856	Thread Indicator and Thread Guide Screw Washer.....
34605	6856	Thread Indicator Plate.....
190W	6859	" " " " Screw.....
34505	6856	" Nipper Adjusting Stud.....
34506	—	" " " " " " 34505 with 22434 to 22436.
1170H	6858	Thread Nipper Adjusting Stud Hole Plug Screw.....
1754E	6858	Thread Nipper Adjusting Stud Lock Nut.
22434	6856	" " " " Washer (leather) lower.....
22435	6856	Thread Nipper Adjusting Stud Washer (leather) upper.....
22436	6856	Thread Nipper Adjusting Stud Washer (steel).....
34212	6856	Thread Nipper Body with two 34560.....
34292	—	Thread Nipper Body complete, Nos. 22440, 22443, 22446, 34212, 34213, 34432, 34455, 34520 and 34561.....

NO.	PLATE	NAME
1125B	6859	Thread Nipper Body Set Screw.....
34430	—	" " Cap.....
*34431	—	" " Stud.....
34432	6856	" " " " 34431 with 34430
22440	6856	" " Washer.....
34213	6856	" " Disc (grooved).....
22443	6856	" " Locking Washer.....
34520	6856	" " " " Cap (leather).....
22446	6856	Thread Nipper Ring.....
34560	6856	" " " Position Pin.....
22449	6860	" " Rod.....
34580	—	" " " 22449 with 1754E and 34506.....
34455	6856	Thread Nipper Spring.....
34561	6856	" " " Washer (micarda).
19075	4237	" Pull-off Lever with 1933.....
19076	4237	" " " Cam with two 460c
460c	4237	" " " " Set Screw....
701D	6859	" " " Hinge Screw.....
1933	4237	" " " Roller and Stud...
29939	6856	" Retaining Disc.....
1562J	6858	" " Regulating Thumb Nut
418D	6858	" " Screw Stud.....
1735H	6858	" " " " Nut.....
43808	6856	" " Spring.....
22456	4237	" Take-up.....
22458	4237	" Guide (top of arm).....
9606	6855	Throat Plate for 9578.....
244J	6855	" " Screw.....

SINGER Needles should be used
in SINGER Machines.
These Needles and their Containers
are marked with the
Company's Trade Mark "SIMANCO.**" 1

Needles in Containers marked
"FOR SINGER MACHINES"
are NOT **SINGER** made needles. 2

**LIST OF PARTS COMPLETE
FOR**

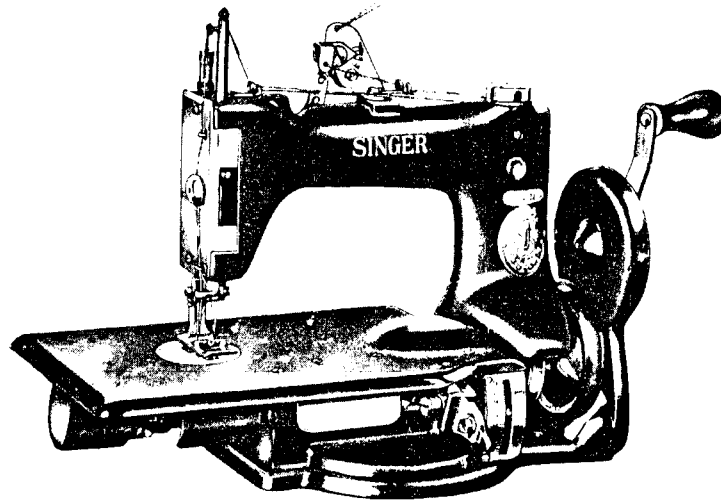

MACHINE No. 24-71

FOR SEWING ON LAUNDRY TAGS. HAS TWO NEEDLES, TWO LOOPERS; GAUGES FROM $\frac{1}{8}$ INCH TO $\frac{5}{8}$ INCH. THE MACHINE IS DESIGNED FOR USE IN LAUNDRIES FOR SEWING THE MARKING TAPE ON VARIOUS ARTICLES. THE TAPE IS STITCHED ON THE SIDES ONLY. THE MACHINE IS OPERATED BY HAND ATTACHMENT NO. 34616. HAS AUTOMATIC TENSION AND GRADUATED THREAD MEASURING DEVICE. THE GRADUATIONS ARE MADE TO AGREE WITH THOSE ON THE FEED REGULATOR INDEX PLATE. BY SETTING THE POINTERS ON THE MEASURING DEVICE AND THE FEED REGULATOR INDEX PLATE ON THE SAME FIGURE, THE EXACT AMOUNT OF THREAD REQUIRED FOR EACH STITCH WILL BE PULLED OFF. A KNIFE IS ATTACHED TO THE LOOPERS AND AT THE COMPLETION OF THE OPERATION, THE TURNING OF THE BALANCE WHEEL IN THE REVERSE DIRECTION CUTS THE THREAD CLOSE TO THE MATERIAL.

NO.	PLATE	NAME
*34607	---	Arm, upper and lower (solid) with 130D and 34007.....

NO.	PLATE	NAME
34589	6861	Arm Rock Shaft.....
32034	6857	" " " Crank (back) with 1259c and 1439c.....
1439c	6857	Arm Rock Shaft Crank (back) Position Screw.....
1259c	6857	Arm Rock Shaft Crank (back) Set Screw
34116	6857	" " " " (front) with two 1259c.....
1259c	6857	Arm Rock Shaft Crank (front) Set Screw
34235	6861	" Rotary Shaft with 1019c.....
34002	4248	" " " Gear with two 462c.....
462c	4248	" " " " Set Screw.....
199D	6859	" " " " Screw.....
34608	6860	Balance Wheel, 2 in. pulley.....
34191	4246	Cloth Plate with three 1602e.....
1602e	6858	" " Bushing.....
1104F	6859	" " " Screw (large).....
219F	6859	" " " " (small).....
34433	6861	Connecting Rod with 34434 and two 171e
*34434	---	" " Cap.....
171e	6859	" " " " Screw.....
1139c	6859	" " " Hinge Screw.....
1520j	6858	" " " " " Nut.....
34192	4248	Face Plate with 2827 and 34079.....
337D	6859	" " " " " Screw.....
34079	4248	" " " " " Thread Guard (lower) with 8505.....
8505	6858	Face Plate Thread Guard (lower) Rivet..
2827	6858	" " " " " (upper) with 8505.....
8505	6858	Face Plate Thread Guard (upper) Rivet..
9543	6857	" " " " " Nipper Disc.....
9544	6857	" " " " " " " Cover....
228D	6857	" " " " " " " " Screw
9600	6857	" " " " " " " " Spring (heavy).....
9545	6857	Face Plate Thread Nipper Disc Spring (light).....
22338	6857	Feed Bar with 152F and 207c.....
152F	6857	" " " " " Adjusting Screw.....
22339	4224	" " " " " Hinge Pin.....
207c	4224	" " " " " " " Set Screw.....
9626	6855	" " " " " Dog, 15 teeth (12 teeth to the inch)

NOTE: When ordering No. 9626 state gauge required.

190D 6859 Feed Dog Screw.....

NO.	PLATE	NAME
34187	6858	Feed Eccentric with two 1259c.....
34090	4224	" " Collar with 452c.....
	452c	" " " Set Screw.....
	1259c	6857 " " Set Screw.....
34091	4224	" " Sleeve.....
34092	4224	" Forked Connection.....
	378c	4224 " " Hinge Screw....
	1520j	6858 " " " " Nut
	1832	4224 " " " Roller with 1085c
	1085c	4224 " " " Screw Stud
34189	6858	" Lifting Eccentric with two 1259c...
	1259c	6857 " " Set Screw.....
34094	4225	" Regulator.....
34095	4225	" " Crank with 230F and 34096.....
34096	4225	Feed Regulator Crank Pin.....
	230F	4225 " " Set Screw.....
	1215E	4225 " " Hinge Screw.....
34097	4225	" " Indicator.....
34211	4225	" " Hinge Pin.....
34098	4225	" " Plate.....
	335D	4225 " " " Screw....
	1083c	4225 " " Locking Screw.....
34099	4225	" " Washer..
34100	4225	" Rock Shaft.....
34101	---	Feed Rock Shaft complete, Nos. 34100 and 34102.....
*34007	---	Feed Rock Shaft and Looper Shaft Bracket with 145E.....
	130D	6859 Feed Rock Shaft and Looper Shaft Bracket Screw.....
34102	4225	Feed Rock Shaft Crank with 157B.....
	157B	4225 " " " Clamping Screw.
	307c	4225 " " " Screw Center.....
56814	---	" " " " " 307c with 1513J.....
	1513J	4225 Feed Rock Shaft Screw Center Nut.....
35131	6860	Guide.....
	286D	6859 " Thumb Screw.....
34287	6860	Looper Cover with 34288.....
34288	6857	" " Stud.....
34609	6855	" (left hand) with 34610.....

Note: When ordering No. 34609 state gauge required.

34008	4248	Looper (left hand) Driving Shaft.....
34009	4248	" " " " Gear (left hand) with two 462c.....

NO.	PLATE	NAME
34010	4246	Looper (left hand) Driving Shaft Gear (left hand) Cover.....
	164D	4248 Looper (left hand) Driving Shaft Gear (left hand) Cover Screw.....
	462c	4248 Looper (left hand) Driving Shaft Gear (left hand) Set Screw.....
34002	4248	Looper (left hand) Driving Shaft Gear (right hand) with two 462c.....
34011	4246	Looper (left hand) Driving Shaft Gear (right hand) Cover.....
	578F	4248 Looper (left hand) Driving Shaft Gear (right hand) Cover Screw.....
	462c	4248 Looper (left hand) Driving Shaft Gear (right hand) Set Screw.....
	460c	4237 Looper (left hand) Set Screw.....
34030	6858	" " " Shaft with 460c.....
	9640	6858 " " " Bushing with 1264E.....
	145E	6859 Looper (left hand) Shaft Bushing Clamping Screw.....
	1264E	6859 Looper (left hand) Shaft Bushing Position Screw.....
34012	6857	Looper (left hand) Shaft Gear with two 462c.....
	462c	4248 Looper (left hand) Shaft Gear Set Screw.
*34610	---	" " " Thread Cutting Knife
34600	6855	" (right hand) with 34601.....

Note: When ordering No. 34600 state gauge required.

	1019c	4229 Looper (right hand) Set Screw.....
*34601	---	" " " Thread Cutting Knife
34080	6856	Needle Bar with 2273.....
34170	4229	" " Connecting Link with two 1313E.....
	1313E	4229 Needle Bar Connecting Link Adjusting Screw.....
	9570	4229 Needle Bar Connecting Stud with 207E...
	207E	4224 " " " Clamping Screw.....
	9611	4229 Needle Bar Thread Tube.....
34013	6857	" Clamp with 230H and two 620F...
	620F	4248 " Set Screw.....
	230H	4225 " Set Screw.....
	2273	6856 " Stop Pin.....
34103	4229	Presser Bar.....
34104	4229	" " Guide Bracket with 223E.....

NO.	PLATE	NAME
223E	4229	Presser Bar Guide Bracket Adjusting Screw.....
34105	4229	Presser Bar Guide Bracket Guide.....
457C	4229	" " " " " Set Screw.....
999F	4229	" " " " " Set Screw.....
38540	4229	" " " " " Lifter.....
50293E	6859	" " " " " Hinge Screw.....
1521J	6858	" " " " " Nut.....
9534	4229	" " " " " Spring.....
22405	4229	" " " " " Washer.....
34611	6855	" " " " " Foot.....
NOTE: When ordering No. 34611 state gauge required and also furnish sample of tape.		
185H	6859	Presser Foot Screw.....
1121J	4229	Pressure Regulating Thumb Screw.....
34599	6860	Pulley and Thread Nipper Rod Eccentric, 2 3/8 in. diam.....
1167E	4224	Pulley and Thread Nipper Rod Eccentric Screw.....
34028	6857	Thread Eyelet (double) top of arm.....
330D	6859	" " " " " Screw.....
34604	6856	" " " " " Indicator and Thread Guide.....
34612	---	" " " " " " " 34604 with 418D, 1562J, 23258, 34605, 34613, 43808, 50222D and two each 1735H and 29939.....
50222D	6859	Thread Indicator and Thread Guide Screw.....
1735H	6858	" " " " " " " " Nut.....
23258	6856	Thread Indicator and Thread Guide Screw Washer.....
34605	6856	Thread Indicator Plate.....
190W	6859	" " " " " Screw.....
34505	6856	" " " " " Nipper Adjusting Stud.....
34506	---	" " " " " " " 34505 with 22434 to 22436.....
1170H	6858	Thread Nipper Adjusting Stud Hole Plug Screw.....
1754E	6858	Thread Nipper Adjusting Stud Lock Nut.....
22434	6856	" " " " " " " Washer (leather) lower.....
22435	6856	Thread Nipper Adjusting Stud Washer (leather) upper.....
22436	6856	Thread Nipper Adjusting Stud Washer (steel).....

NO.	PLATE	NAME
34212	6856	Thread Nipper Body with two 34560.....
34292	---	Thread Nipper Body complete, Nos. 22440, 22443, 22446, 34212, 34213, 34432, 34455, 34520 and 34561.....
1125B	6859	Thread Nipper Body Set Screw.....
34430	---	" " " " " Cap.....
*34431	---	" " " " " Stud.....
34432	6856	" " " " " 34431 with 34430.....
22440	6856	" " " " " Washer.....
34213	6856	" " " " " Disc (grooved).....
22443	6856	" " " " " Locking Washer.....
34520	6856	" " " " " " " C a p (leather).....
22446	6856	Thread Nipper Ring.....
34560	6856	" " " " " Position Pin.....
22449	6860	" " " " " Rod.....
34580	---	" " " " " 22449 with 1754E and 34506.....
34455	6856	Thread Nipper Spring.....
34561	6856	" " " " " Washer (micarda).....
19075	4237	" " " " " Pull-off Lever with 1933.....
19076	4237	" " " " " Cam with two 460C.....
460C	4237	" " " " " " " Set Screw.....
701D	6859	" " " " " " " Hinge Screw.....
1933	4237	" " " " " " " Roller and Stud.....
29939	6856	" " " " " Retaining Disc.....
1562J	6858	" " " " " " " Regulating Thumb Nut.....
418D	6858	" " " " " " " Screw Stud.....
1735H	6858	" " " " " " " " Nut.....
43808	6856	" " " " " " " Spring.....
34613	6856	" " " " " Separating Disc.....
9699	6855	Throat Plate, for 9626.....

NOTE: When ordering No. 9699 state gauge required.

244J 6855 Throat Plate Screw.....

HAND ATTACHMENT PARTS

FOR 24-71 MACHINE

NO.	PLATE	NAME
34614	6863	Base with two 34075.....
34075	6857	" " " " " Position Stud.....
34076	6863	Bracket.....
690D	6859	" " " " " Screw.....

NO.	PLATE	NAME
7962	6861	Crank Handle (wood).....
7963	----	“ “ Stud.....
7964	----	“ “ “ Washer.....
34615	6861	“ Lever.....
50137j	6859	“ “ Screw.....
34617	6861	Crank complete, Nos. 7962 to 7964 and 34615.....
34618	6863	Driver.....
34072	6857	“ Pinion.....
1327F	6859	“ “ Screw Stud.....
1620j	6858	“ “ “ “ Nut.....
240D	6859	“ “ Set Screw.....
34619	6860	Gear.....
9566	6860	“ Cover.....
399A	6859	“ “ Screw.....
659D	6859	“ Screw Stud.....
34073	6857	Pinion (intermediate).....
45F	6859	“ “ Screw Stud.....
34616	6863	Hand Attachment complete, Nos. 45F, 240D, 659D, 1327F, 1620J, 9566, 34072, 34073, 34076, 34614, 34617 to 34619 and two each 399A, 690D, 50137J and wood screws 1 in. No. 13.....

PARTS FOR NEEDLE BAR STOP DEVICE

THESE PARTS ARE FURNISHED WITH THE 24-71 MACHINE
ONLY UPON REQUEST

NO.	PLATE	NAME
34624	6864	Needle Bar Stop Lever.....
701c	6864	“ “ “ “ Hinge Screw.....
34625	6864	“ “ “ “ Spring.....
170j	6864	“ “ “ “ “ Stud.....
34626	6864	“ “ “ “ Stop Collar with two I259c.....
1259c	6864	Needle Bar Stop Lever Stop Collar Set Screw.....

ACCESSORIES

NO.	PLATE	NAME
9843	6862	Machine Cushion (cloth).....
474j	6861	“ Thumb Screw, for power table, for 24-70 Machine.....

NO.	PLATE	NAME
1152j	6861	Machine Thumb Screw, for power table, for 24-71 Machine.....
2015	6857	Machine Thumb Screw Cushion (rubber).
9842	6857	“ “ “ Washer.....
36569	4235	Oiler with 36571.....
36570	----	“ 36569, filled with oil.....
36571	4235	“ Spout, 1¼ in. long, with 36807.....
36807	6857	“ “ Washer (leather).....
26026	4235	Screw Driver.....
25539	4235	Stiletto.....
19079	6858	Wrench for 1629.....

FOOT LIFTER PARTS

NO.	PLATE	NAME
6439	----	Chain, 36 in. to 45 in., with 56864 and 56865.....

NOTE: When ordering 6439, state length required.

4879	4235	Chain Connecting Link.....
56864	6858	“ Hook (large).....
56865	6858	“ “ (small).....
34110	4235	Lifting Lever.....
21D	6859	“ “ Hinge Screw.....
34111	6858	“ “ Link.....
766D	6859	“ “ “ Hinge Screw.....
19081	6858	“ “ Spring.....
184D	6859	“ “ Stop Screw.....
4881	4236	Treadle.....
4882	4235	“ Shaft.....
4883	4235	“ Spring.....
4884	4236	“ Stand.....
4885	4236	Treadle complete, Nos. 4879, 4881 to 4884 and two wood screws 1 in. No. 16.....
34118	----	Foot Lifter complete, Nos. 21D, 184D, 766D, 4885, 6439, 19081, 34110 and 34111.....

KNEE LIFTER PARTS

NO.	PLATE	NAME
14224	----	Chain, length 10¼ in., with 56864.....
56864	6858	“ Hook.....
34110	4235	Lifting Lever.....
21D	6859	“ “ Hinge Screw.....
34111	6858	“ “ Link.....

KNEE LIFTER PARTS

NO.	PLATE	NAME
766d	6859	Lifting Lever Link Hinge Screw.....
19081	6858	" " Spring.....
184d	6859	" " Stop Screw.....
7124	4236	Rock Shaft.....
2764	4236	" " Hanger with two wood screws 1 in. No. 10.....
6335	4236	Rock Shaft Knee Arm.....
6336	—	" " " " 6335 with 2766 and 2767.....
2766	4236	Rock Shaft Knee Arm Hub with 356c....
356c	6859	" " " " " Set Screw....
2767	4236	" " " " Plate with 356c....
356c	6859	" " " " " Set Screw....
6337	4236	" " Lifting Bracket with two 356c
7125	4236	" " " " Hook.....
356c	6859	" " " " " Set Screw....
356c	6859	" " " " " Set Screw....
2770	4236	" " Stop Dog with 356c.....
356c	6859	" " " " " Set Screw.....
7126	4236	Rock Shaft complete, Nos. 2770, 6336, 6337, 7124, 7125 and two 2764.....
34204	—	Knee Lifter complete (power table) Nos. 21d, 184d, 766d, 7126, 14224, 19081, 34110 and 34111.....

TAPE HOLDER

1/8 IN. DISC

NO.	PLATE	NAME
26056	2785	Bracket with tape guide.....
26057	2785	Disc.....
26058	6858	" Sleeve.....
1541d	6858	Tension Regulating Thumb Nut.....
26059	6858	" Spring.....
26060	2785	Tape Holder complete, Nos. 1520j, 1541d and 26056 to 26059.....
1520j	6858	Tape Holder Nut.....

THREAD UNWINDER

(FOR TWO SPOOLS)

FOR 24-71 MACHINE

NO.	PLATE	NAME
225395	7233	Spool Rest with 201018c.....
225388	7233	" " Rod.....

THREAD UNWINDER

NO.	PLATE	NAME
200383c	6859	Spool Rest Rod Set Screw.....
201018c	6859	" " Set Screw.....
202490	7233	" Stand with 200383c.....
225391	7233	Thread Guide.....
201696j	6858	" " Lock Nut.....
225326	6862	" " Position Cup.....
225324	6862	" " Rod with 208E and 225322
208E	6859	" " " Screw.....
225322	6857	" " " Washer.....
225396	7233	Thread Unwinder complete, Nos. 201696i, 202490, 225324, 225326, 225388, 225395, two 225391 and three wood screws 1/8 in. No. 12.....
27739	6862	Thread Cone (wood) for large cones.....
225390	6862	" " Holder, for inverted cones..

NOTE: Nos. 27739 and 225390 are used with,
but not included in 225396.

SINGER Needles should be used
in SINGER Machines.
These Needles and their Containers
are marked with the
Company's Trade Mark "SIMANCO.***" 1

Needles in Containers marked
"FOR SINGER MACHINES"
are NOT **SINGER** made needles. 2

NUMERICAL LIST OF PARTS

NO. PLATE	NAME
21d 6859	Lifting Lever Hinge Screw for 34118 and 34204.....
45f 6859	Hand Attachment Pinion (intermediate) Screw Stud for 34616.....
130d 6859	Feed Rock Shaft Bracket Screw for 34357
130d 6859	" " " and Looper Shaft Bracket Screw for 34607.....
145e 6859	Looper (left hand) Shaft Bushing Clamping Screw for 34007.....
152f 6857	Feed Bar Adjusting Screw for 22338.....
157b 4225	" Rock Shaft Crank Clamping Screw for 34102.....
164d 4248	Looper (left hand) Driving Shaft Gear (left hand) Cover Screw for 24-71 Machine.....
170j 6864	Needle Bar Stop Lever Spring Stud for 24-71 Machine.....
171e 6859	Connecting Rod Cap Screw for 34433.....
184d 6859	Lifting Lever Stop Screw for 34118 and 34204.....
185h 6859	Presser Foot Screw.....
190d 6859	Feed Dog Screw.....
190w 6859	Thread Indicator Plate Screw.....
199d 6859	Arm Rotary Shaft Screw.....
207c 4224	Feed Bar Hinge Pin Set Screw for 22338 and 34088.....
207e 4224	Needle Bar Connecting Stud Clamping Screw for 9570.....
208e 6859	Thread Unwinder Thread Guide Rod Screw for 225324.....
219f 6859	Cloth Plate Screw (small).....
223e 4229	Presser Bar Guide Bracket Adjusting Screw for 34104.....
228d 6857	Face Plate Thread Nipper Disc Cover Screw for 24-71 Machine.....
230f 4225	Feed Regulator Crank Set Screw for 34095
230h 4225	Needle Set Screw for 34013.....
240b 6859	Hand Attachment Driver Pinion Set Screw for 34616.....
244j 6855	Throat Plate Screw.....
286d 6859	Guide Thumb Screw.....
307c 4225	Feed Rock Shaft Screw Center for 56814.
330d 6859	Thread Eyelet Screw for 24-71 Machine..

NUMERICAL LIST OF PARTS

NO. PLATE	NAME
335D 4225	Feed Regulator Indicator Plate Screw...
337D 6859	Face Plate Screw.....
356c 6859	Rock Shaft Knee Arm Hub Set Screw for 2766.....
356c 6859	Rock Shaft Knee Arm Plate Set Screw for 2767.....
356c 6859	Rock Shaft Lifting Bracket Hook Set Screw for 6337.....
356c 6859	Rock Shaft Lifting Bracket Set Screw for 6337.....
356c 6859	Rock Shaft Stop Dog Set Screw for 2770
378c 4224	Feed Forked Connection Hinge Screw....
399A 6859	Hand Attachment Gear Cover Screw for 34616.....
418D 6858	Thread Retaining Screw Stud for 34606 and 34612.....
452c 4224	Feed Eccentric Collar Set Screw for 34090
457c 4229	Presser Bar Guide Bracket Guide Set Screw.....
460c 4237	Looper (left hand) Set Screw for 34030...
460c 4237	Thread Controller Post Set Screw for 24-70 Machine.....
460c 4237	Thread Pull-off Lever Cam Set Screw for 19076.....
462c 4248	Arm Rotary Shaft Gear Set Screw for 34002.....
462c 4248	Looper (left hand) Driving Shaft Gear (left hand) Set Screw for 34009.....
462c 4248	Looper (left hand) Driving Shaft Gear (right hand) Set Screw for 34002.....
462c 4248	Looper (left hand) Shaft Gear Set Screw for 34012.....
474J 6861	Machine Thumb Screw, for power table, for 24-70 Machine (Accessories).....
578F 4248	Looper (left hand) Driving Shaft Gear (right hand) Cover Screw for 24-71 Ma- chine.....
620F 4248	Needle Clamp Set Screw for 34013.....
659D 6859	Hand Attachment Gear Screw Stud for 34616.....
690D 6859	Hand Attachment Bracket Screw for 34616
691A 6859	Spool Thread Guiding Disc Screw for 24-70 Machine.....
701c 6864	Needle Bar Stop Lever Hinge Screw for 24-71 Machine.....
701D 6859	Thread Pull-off Lever Hinge Screw.....

NUMERICAL LIST OF PARTS

NO. PLATE	NAME
766D 6859	Lifting Lever Link Hinge Screw for 34118 and 34204.....
999F 4229	Presser Bar Guide Bracket Set Screw.....
1008D 6859	Spool Bracket Screw for 24-70 Machine...
1009c 6859	" Spindle Set Screw for 34137.....
1019c 4229	Looper Set Screw for 34186.....
1019c 4229	" (right hand) Set Screw for 34235..
1083c 4225	Feed Regulator Locking Screw.....
1085c 4224	" Forked Connection Roller Screw Stud for 1832.....
1104F 6859	Cloth Plate Screw (large).....
1105E 4229	Looper Gate Hinge Screw for 24-70 Ma- chine.....
1121J 4229	Pressure Regulating Thumb Screw.....
1125B 6859	Thread Nipper Body Set Screw.....
1139c 6859	Connecting Rod Hinge Screw.....
1152J 6861	Machine Thumb Screw, for power table, for 24-71 Machine (Accessories).....
1167E 4224	Pulley and Thread Nipper Rod Eccentric Screw.....
1170H 6858	Thread Nipper Adjusting Stud Hole Plug Screw.....
1215E 4225	Feed Regulator Hinge Screw.....
1259c 6857	Arm Rock Shaft Crank (back) Set Screw for 32034.....
1259c 6857	Arm Rock Shaft Crank (front) Set Screw for 34116.....
1259c 6857	Feed Eccentric Set Screw for 34187.....
1259c 6857	" Lifting Eccentric Set Screw for 34189
1259c 6864	Needle Bar Stop Lever Stop Collar Set Screw for 34626.....
1264E 6859	Looper (left hand) Shaft Bushing Position Screw for 9640.....
1313E 4229	Needle Bar Connecting Link Adjusting Screw for 34170.....
1327F 6859	Hand Attachment Driver Pinion Screw Stud for 34616.....
1439c 6857	Arm Rock Shaft Crank (back) Position Screw for 32034.....
1513J 4225	Feed Rock Shaft Screw Center Nut for 56814.....
1520J 6858	Connecting Rod Hinge Screw Nut.....
1520J 6858	Feed Forked Connection Hinge Screw Nut
1520J 6858	Tape Holder Nut for 26060.....
1521J 6858	Presser Bar Lifter Hinge Screw Nut.....
1511D 6858	Tape Holder Tension Regulating Thumb Nut for 26060.....

NO.	PLATE	NAME
1562j	6858	Thread Retaining Regulating Thumb Nut for 34606 and 34612.....
1602E	6858	Cloth Plate Bushing for 34086 and 34191
1620j	6858	Hand Attachment Driver Pinion Screw Stud Nut for 34616.....
1629c	4229	Needle Clamping Nut for 24-70 Machine
1735H	6858	Thread Indicator and Thread Guide Screw Nut for 34606 and 34612.....
1735H	6858	Thread Retaining Screw Stud Nut for 34606 and 34612.....
1754E	6858	Thread Nipper Adjusting Stud Lock Nut for 34580.....
1832	4224	Feed Forked Connection Roller with 1085c
1933	4237	Thread Pull-off Lever Roller and Stud for 19075.....
2015	6857	Machine Thumb Screw Cushion, rubber (Accessories).....
2049	6858	Spool Bracket Dowel Pin for 24-70 Machine.....
2273	6856	Needle Stop Pin for 34080.....
2764	4236	Rock Shaft Hanger with two wood screws 1 in. No. 10, for 7126.....
2766	4236	Rock Shaft Knee Arm Hub with 356c, for 6336.....
2767	4236	Rock Shaft Knee Arm Plate with 356c, for 6336.....
2770	4236	Rock Shaft Stop Dog with 356c, for 7126
2827	6858	Face Plate Thread Guard with 8505, for 34311.....
2827	6858	Face Plate Thread Guard (upper) with 8505, for 34192.....
4879	4235	Chain Connecting Link for 4885.....
		Nos. 4881 to 4884 for 4885
4881	4236	Treadle.....
4882	4235	" Shaft.....
4883	4235	" Spring.....
4884	4236	" Stand.....
4885	4236	Treadle complete for 34118, Nos. 4879, 4881 to 4884 and two wood screws 1 in. No. 16.....
6335	4236	Rock Shaft Knee Arm for 6336.....
6336	—	" " " " 6335 with 2766 and 2767 for 7126.....
6337	4236	Rock Shaft Lifting Bracket with two 356c, for 7126.....

NO.	PLATE	NAME
6439	—	Chain, 36 in. to 45 in., with 56864 and 56865, for 34118.....
7124	4236	Rock Shaft for 7126.....
7125	4236	" " Lifting Bracket Hook for 7126
7126	4236	Rock Shaft complete for 34204, Nos. 2770, 6336, 6337, 7124, 7125 and two 2764...
7962	6861	Hand Attachment Crank Handle (wood) for 34617.....
7963	—	Hand Attachment Crank Handle Stud for 34617.....
7964	—	Hand Attachment Crank Handle Stud Washer for 34617.....
8505	6858	Face Plate Thread Guard Rivet for 2827
8505	6858	" " " " (lower) Rivet for 34079.....
8505	6858	Face Plate Thread Guard (upper) Rivet for 2827.....
9534	4229	Presser Bar Spring.....
9543	6857	Face Plate Thread Nipper Disc for 24-71 Machine.....
9544	6857	Face Plate Thread Nipper Disc Cover for 24-71 Machine.....
9545	6857	Face Plate Thread Nipper Disc Spring (light) for 24-71 Machine.....
9566	6860	Hand Attachment Gear Cover for 34616
9570	4229	Needle Bar Connecting Stud with 207E...
9578	6855	Feed Dog, 15 teeth (16 teeth to the inch) for 24-70 Machine.....
9600	6857	Face Plate Thread Nipper Disc Spring (heavy) for 24-71 Machine.....
9606	6855	Throat Plate for 9578, for 24-70 Machine
9611	4229	Needle Bar Thread Tube for 24-71 Machine.....
9626	6855	Feed Dog, 15 teeth (12 teeth to the inch) for 24-71 Machine.....
9640	6858	Looper (left hand) Shaft Bushing with 1264E, for 24-71 Machine.....
9699	6855	Throat Plate, for 9626, for 24-71 Machine
9842	6857	Machine Thumb Screw Washer (Accessories).....
9843	6862	Machine Cushion, cloth (Accessories)...
14224	—	Chain, length 10¼ in., with 56864, for 34204.....
19066	4222	Spool Spindle for 24-70 Machine.....
19067	4222	" Thread Guiding Disc for 24-70 Machine.....

NO.	PLATE	NAME
19075	4237	Thread Pull-off Lever with 1933.....
19076	4237	" " " Cam with two 460c
19079	6858	Wrench for 1629 (Accessories).....
19081	6858	Lifting Lever Spring for 34118 and 34204
22338	6857	Feed Bar with 152F and 207c, for 24-71 Machine.....
22339	4224	Feed Bar Hinge Pin.....
22348	6862	" Rock Shaft Bracket for 34357.....
22349	4229	Looper Gate for 24-70 Machine.....
22350	4229	" " Spring for 24-70 Machine ..
22405	4229	Presser Bar Spring Washer.....
22429	4237	Thread Controller Spring for 34169.....
22434	6856	" Nipper Adjusting Stud Washer (leather) lower, for 34506.....
22435	6856	Thread Nipper Adjusting Stud Washer (leather) upper, for 34506.....
22436	6856	Thread Nipper Adjusting Stud Washer (steel) for 34506.....
22440	6856	Thread Nipper Cap Washer for 34292.....
22443	6856	" " Locking Washer for 34292.....
22446	6856	" " Ring for 34292.....
22449	6860	" " Rod for 34580.....
22456	4237	" Take-up for 34134.....
22458	4237	" Guide (top of arm) for 24-70 Ma- chine.....
23258	6856	Thread Indicator and Thread Guide Screw Washer for 34606 and 34612.....
25539	4235	Stiletto (Accessories).....
26026	4235	Screw Driver (Accessories).....
Nos. 26056 to 26059 FOR 26060		
26056	2785	Tape Holder Bracket with tape guide....
26057	2785	" " Disc.....
26058	6858	" " " Sleeve.....
26059	6858	" " " Tension Spring.....
26060	2785	Tape Holder, 1 7/8 in. disc, complete, Nos. 1520j, 1541b and 26056 to 26059.....
27739	6862	Thread Unwinder Thread Cone (wood) for large cones, for 225396.....
29939	6856	Thread Retaining Disc for 34606 and 34612.....
32026	6860	Balance Wheel, 2 in. pulley, for 24-70 Machine.....
32034	6857	Arm Rock Shaft Crank (back) with 1259c and 1439c.....
34002	4248	Arm Rotary Shaft Gear with two 462c, for 24-71 Machine.....

NO.	PLATE	NAME
34002	4248	Looper (left hand) Driving Shaft Gear (right hand) with two 462c, for 24-71 Machine.....
*34007	—	Feed Rock Shaft and Looper Shaft Bracket with 145E, for 34607.....
Nos. 34008 to 34013 FOR 24-71 MACHINE		
34008	4248	Looper (left hand) Driving Shaft.....
34009	4248	" " " " Gear (left hand) with two 462c.....
34010	4246	Looper (left hand) Driving Shaft Gear (left hand) Cover.....
34011	4246	Looper (left hand) Driving Shaft Gear (right hand) Cover.....
34012	6857	Looper (left hand) Shaft Gear with two 462c.....
34013	6857	Needle Clamp with 230H and two 620F... ..
34028	6857	Thread Eyelet (double) top of arm, for 24-71 Machine.....
34030	6858	Looper (left hand) Shaft with 460c, for 24-71 Machine.....
34072	6857	Hand Attachment Driver Pinion for 34616.....
34073	6857	Hand Attachment Pinion (intermediate) for 34616.....
34075	6857	Hand Attachment Base Position Stud for 34614.....
34076	6863	Hand Attachment Bracket for 34616.....
34079	4248	Face Plate Thread Guard (lower) with 8505, for 34192.....
34080	6856	Needle Bar with 2273, for 24-71 Machine.
34086	4222	Cloth Plate with three 1602E, for 24-70 Machine.....
34088	4224	Feed Bar with 207c, for 24-70 Machine..
34090	4224	" Eccentric Collar with 452c.....
34091	4224	" " Sleeve.....
34092	4224	" Forked Connection.....
34093	4224	" Lifting Eccentric Connection for 24-70 Machine.....
34094	4225	Feed Regulator.....
34095	4225	" " Crank with 230F and 34096
34096	4225	" " Pin for 34095.....
34097	4225	" " Indicator.....
34098	4225	" " " Plate.....
34099	4225	" " Locking Screw Washer...
34100	4225	" Rock Shaft for 34101.....

NUMERICAL LIST OF PARTS

NO.	PLATE	NAME
34101	—	Feed Rock Shaft complete, Nos. 34100 and 34102.....
34102	4225	Feed Rock Shaft Crank with 157B, for 34101.....
34103	4229	Presser Bar.....
34104	4229	" " Guide Bracket with 223E.....
34105	4229	" " " " Guide.....
34110	4235	Lifting Lever for 34118 and 34204.....
34111	6858	" " Link for 34118 and 34204.....
34116	6857	Arm Rock Shaft Crank (front) with two 1259c.....
34118	—	Foot Lifter complete, Nos. 21D, 184D, 766D, 4885, 6439, 19081, 34110 and 34111.....
34134	4237	Needle Bar with 22456, for 24-70 Machine.....
34137	6862	Spool Bracket with 1009c, for 24-70 Machine.....
34169	4237	Thread Controller Post with 22429, for 24-70 Machine.....
34170	4229	Needle Bar Connecting Link with two 1313E.....
34171	4237	Thread Eyelet (double) for 24-70 Machine.....
34186	6861	Arm Rotary Shaft with 1019c, for 24-70 Machine.....
34187	6858	Feed Eccentric with two 1259c.....
34189	6858	" Lifting Eccentric with two 1259c.....
34191	4246	Cloth Plate with three 1602E, for 24-71 Machine.....
34192	4248	Face Plate with 2827 and 34079, for 24-71 Machine.....
34204	—	Knee Lifter complete (power table) Nos. 21D, 184D, 766D, 7126, 14224, 19081, 34110 and 34111.....
34211	4225	Feed Regulator Indicator Hinge Pin.....
34212	6856	Thread Nipper Body with two 34560, for 34292.....
34213	6856	Thread Nipper Disc (grooved) for 34292.....
34235	6861	Arm Rotary Shaft with 1019c, for 24-71 Machine.....
34287	6860	Looper Cover with 34288, for 24-71 Machine.....
34288	6857	Looper Cover Stud for 34287.....
34292	—	Thread Nipper Body complete, Nos. 22440, 22443, 22446, 34212, 34213, 34432, 34455, 34520 and 34561.....
34311	6860	Face Plate with two 2827, for 24-70 Machine.....

NUMERICAL LIST OF PARTS

NO.	PLATE	NAME
*34357	—	Arm, upper and lower (solid) with 130D and 22348, for 24-70 Machine.....
34418	6855	Looper Washer for 24-70 Machine.....
34430	—	Thread Nipper Cap for 34432.....
*34431	—	" " " Stud for 34432.....
34432	6856	" " " " 34431 with 34430, for 34292.....
34433	6861	Connecting Rod with 34434 and two 171E.....
*34434	—	" " Cap for 34433.....
34455	6856	Thread Nipper Spring for 34292.....
34505	6856	" " Adjusting Stud for 34506.....
34506	—	" " " " 34505 with 22434 to 22436, for 34580.....
34520	6856	Thread Nipper Locking Washer Cap (leather) for 34292.....
34560	6856	Thread Nipper Ring Position Pin for 34212.....
34561	6856	" " Spring Washer (micarda) for 34292.....
34580	—	Thread Nipper Rod 22449 with 1754E and 34506.....
34589	6861	Arm Rock Shaft.....
34599	6860	Pulley and Thread Nipper Rod Eccentric, 2 $\frac{3}{8}$ in. diam.....
34600	6855	Looper with 34601, for 24-70 Machine.....
34600	6855	" (right hand) with 34601, for 24-71 Machine.....
*34601	—	Looper Thread Cutting Knife for 34600.....
*34601	—	" (right hand) Thread Cutting Knife for 34600.....
34602	6855	Presser Foot with 34603 and 50470J, for 24-70 Machine.....
34603	6855	Presser Foot Spring Guide for 34602.....
34604	6856	Thread Indicator and Thread Guide for 34606 and 34612.....
34605	6856	Thread Indicator Plate for 34606 and 34612.....
34606	—	Thread Indicator and Thread Guide 34604 with 418D, 1562J, 23258, 34605, 43808, 50222D and two each 1735H and 29939, for 24-70 Machine.....
*34607	—	Arm, upper and lower (solid) with 130D 34007, for 24-71 Machine.....
34608	6860	Balance Wheel, 2 in. pulley, for 24-71 Machine.....
34609	6855	Looper (left hand) with 34610, for 24-71 Machine.....

NUMERICAL LIST OF PARTS

NO.	PLATE	NAME
*34610	---	Looper (left hand) Thread Cutting Knife for 34609.....
34611	6855	Presser Foot for 24-71 Machine.....
34612	---	Thread Indicator and Thread Guide 34604 with 418d, 1562j, 23258, 34605, 34613, 43808, 50222d and two each 1735h and 29939, for 24-71 Machine.....
34613	6856	Thread Separating Disc for 34612.....
34614	6863	Hand Attachment Base with two 34075, for 34616.....
34615	6861	Hand Attachment Crank Lever for 34617
34616	6863	Hand Attachment complete for 24-71 Machine, Nos. 45F, 240D, 659D, 1327F, 1620J, 9566, 34072, 34073, 34076, 34614, 34617 to 34619 and two each 399A, 690D, 50137J and wood screws 1 in. No. 13....
34617	6861	Hand Attachment Crank complete for 34616, Nos. 7962 to 7964 and 34615....
34618	6863	Hand Attachment Driver for 34616.....
34619	6860	" " Gear for 34616.....
34624	6864	Needle Bar Stop Lever for 24-71 Machine
34625	6864	" " " " Spring for 24-71 Machine.....
34626	6864	Needle Bar Stop Lever Stop Collar for 24-71 Machine.....
35131	6860	Guide.....
36569	4235	Oiler with 36571, for 36570.....
36570	---	" 36569, filled with oil (Accessories)...
36571	4235	" Spout, 1 $\frac{3}{4}$ in. long, with 36807, for 36569.....
36807	6857	Oiler Spout Washer (leather) for 36571....
38540	4229	Presser Bar Lifter.....
43808	6856	Thread Retaining Spring for 34606 and 34612.....
50137J	6859	Hand Attachment Crank Lever Screw for 34616.....
50222D	6859	Thread Indicator and Thread Guide Screw for 34606 and 34612.....
50293E	6859	Presser Bar Lifter Hinge Screw.....
50470J	6855	" Foot Spring Guide Screw for 34602
56814	---	Feed Rock Shaft Screw Center 307c with 1513J.....
56861	6858	Chain Hook for 14224.....
56864	6858	" " (large) for 6439.....
56865	6858	" " (small) for 6439.....
200383c	6859	Thread Unwinder Spool Rest Rod Set Screw for 202490.....

NUMERICAL LIST OF PARTS

NO.	PLATE	NAME
201018c	6859	Thread Unwinder Spool Rest Set Screw for 225395.....
201696j	6858	Thread Unwinder Thread Guide Lock Nut for 225396.....
202490	7233	Thread Unwinder Spool Stand with 200383c, for 225396.....
225322	6857	Thread Unwinder Thread Guide Rod Washer, for 225324.....
225324	6862	Thread Unwinder Thread Guide Rod with 208E and 225322, for 225396.....
225326	6862	Thread Unwinder Thread Guide Position Cup for 225396.....
225388	7233	Thread Unwinder Spool Rest Rod for 225396.....
225390	6862	Thread Unwinder Thread Cone Holder, for inverted cones, for 225396.....
225391	7233	Thread Unwinder Thread Guide for 225396.....
225395	7233	Thread Unwinder Spool Rest with 201018c, for 225396.....
225396	7233	Thread Unwinder complete, for two spools, for 24-71 Machine, Nos. 201696j, 202490, 225324, 225326, 225388, 225395, two 225391 and three wood screws $\frac{7}{8}$ in. No. 12.....

SINGER Needles should be used
in SINGER Machines.
These Needles and their Containers
are marked with the
Company's Trade Mark "SIMANCO.**" 1

Needles in Containers marked
"FOR SINGER MACHINES"
are NOT **SINGER** made needles. 2

PLATE 2785 - ONE-HALF SIZE

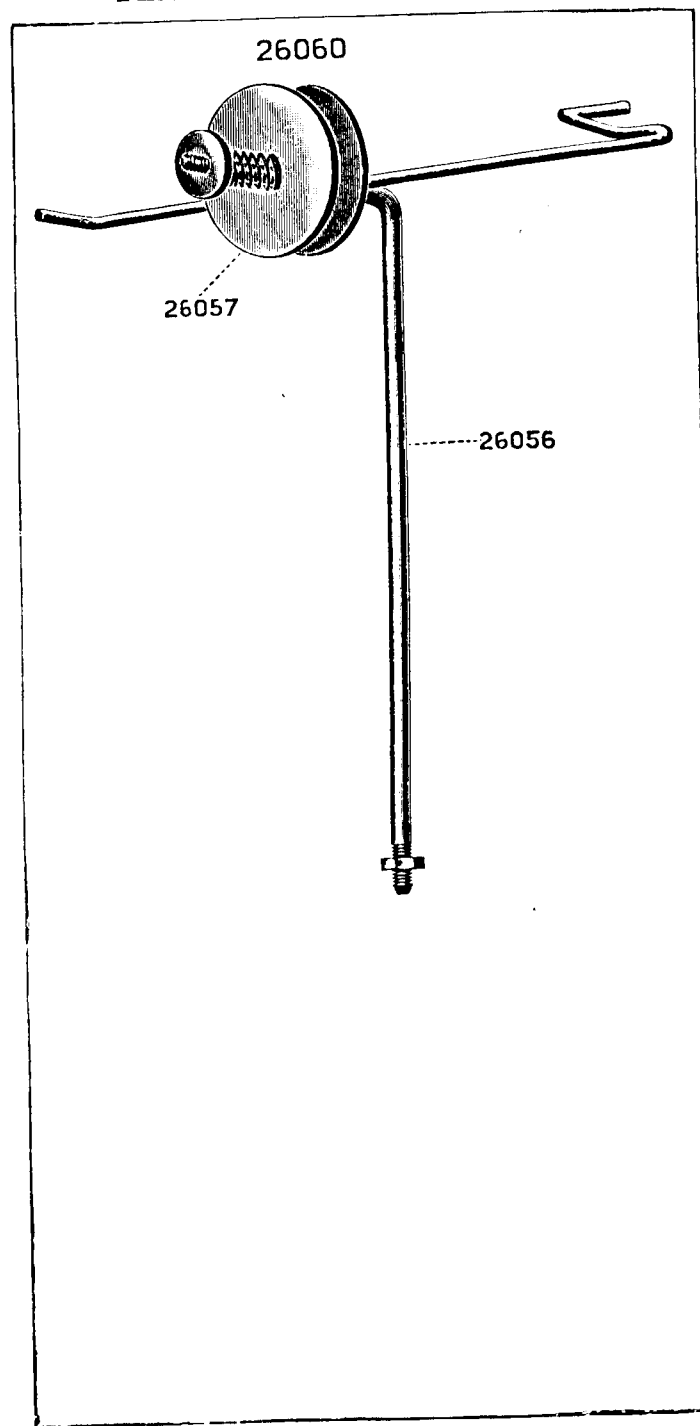

INDUSTRIAL

2785

PLATE 4222—ONE-HALF SIZE

34086

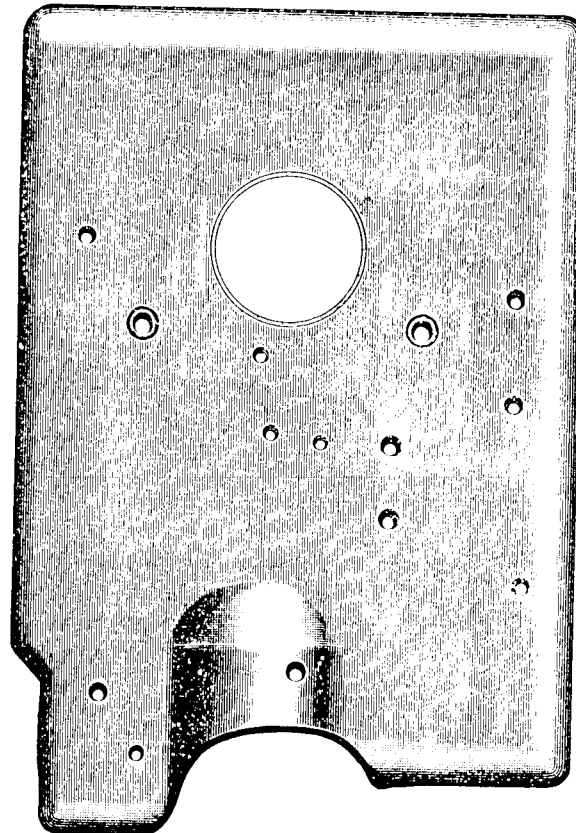

19066



19067

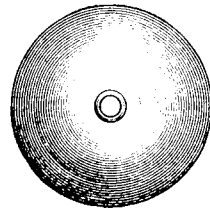

19064

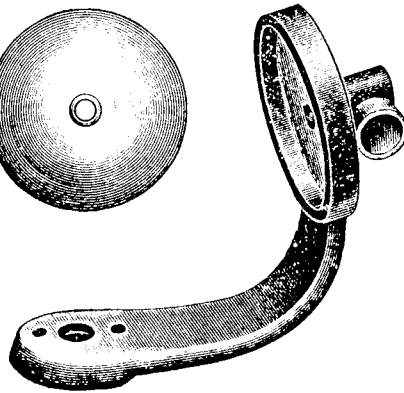
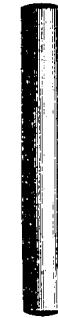
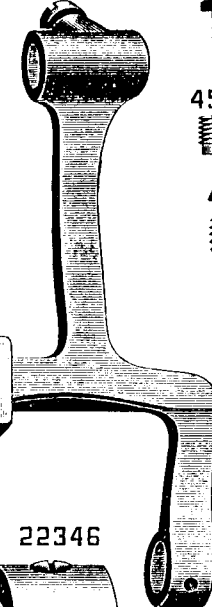

PLATE 4224—FULL SIZE

22339



34088



207



34089

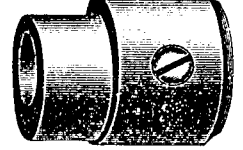

452



34090

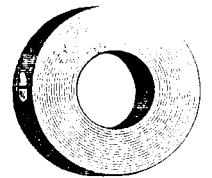

453



34092

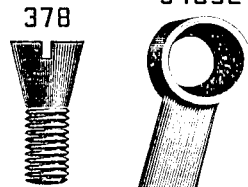

22346

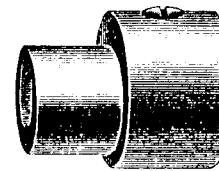

34091

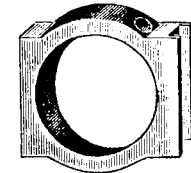

34093

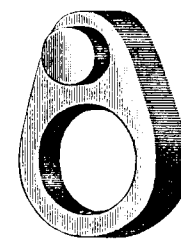

1167



1832

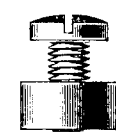

15182

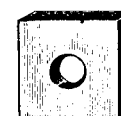

1085



PLATE 4225—FULL SIZE

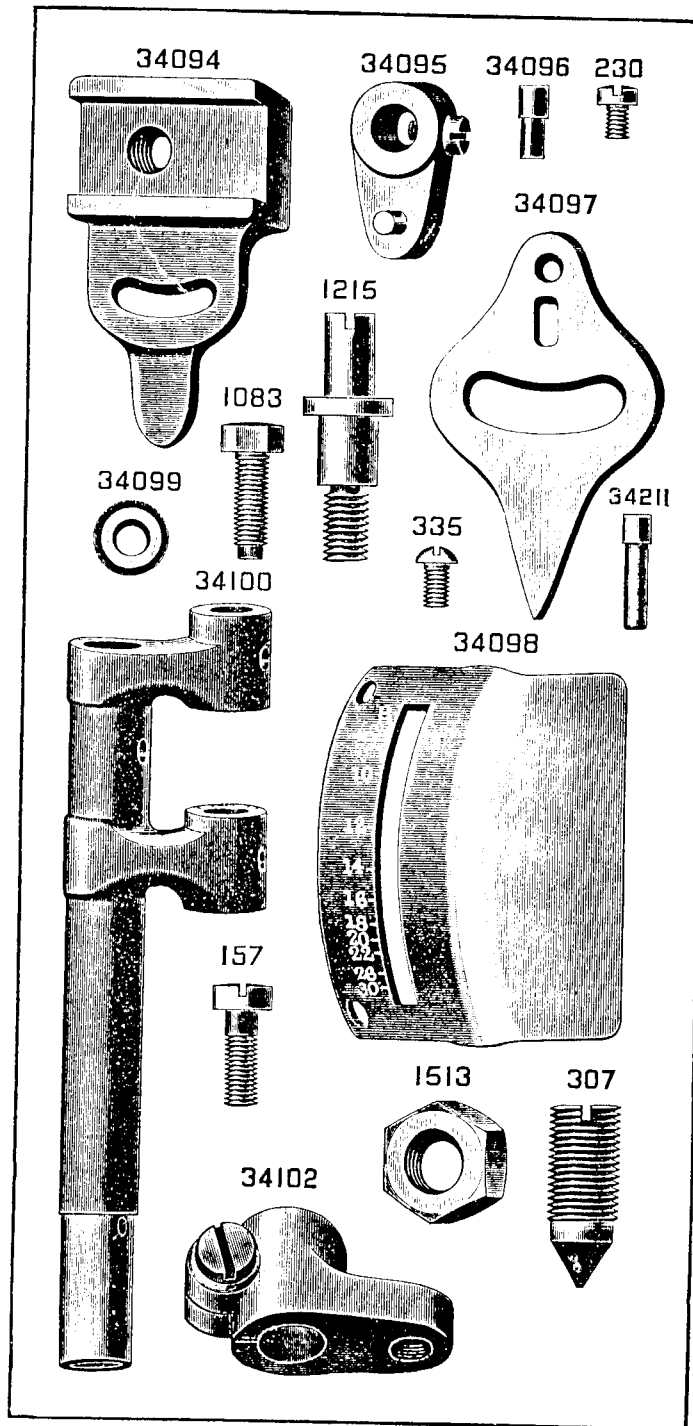

PLATE 4229—FULL SIZE

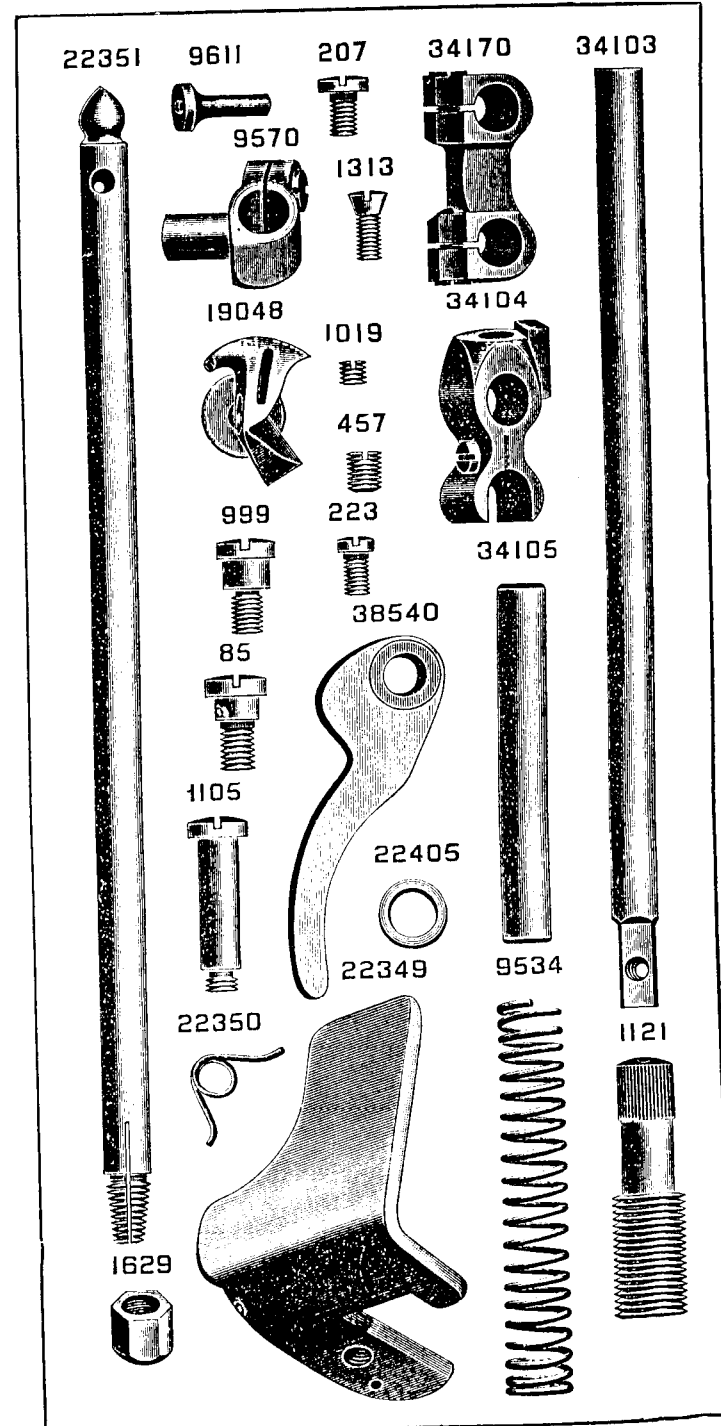

PLATE 4235—ONE-HALF SIZE

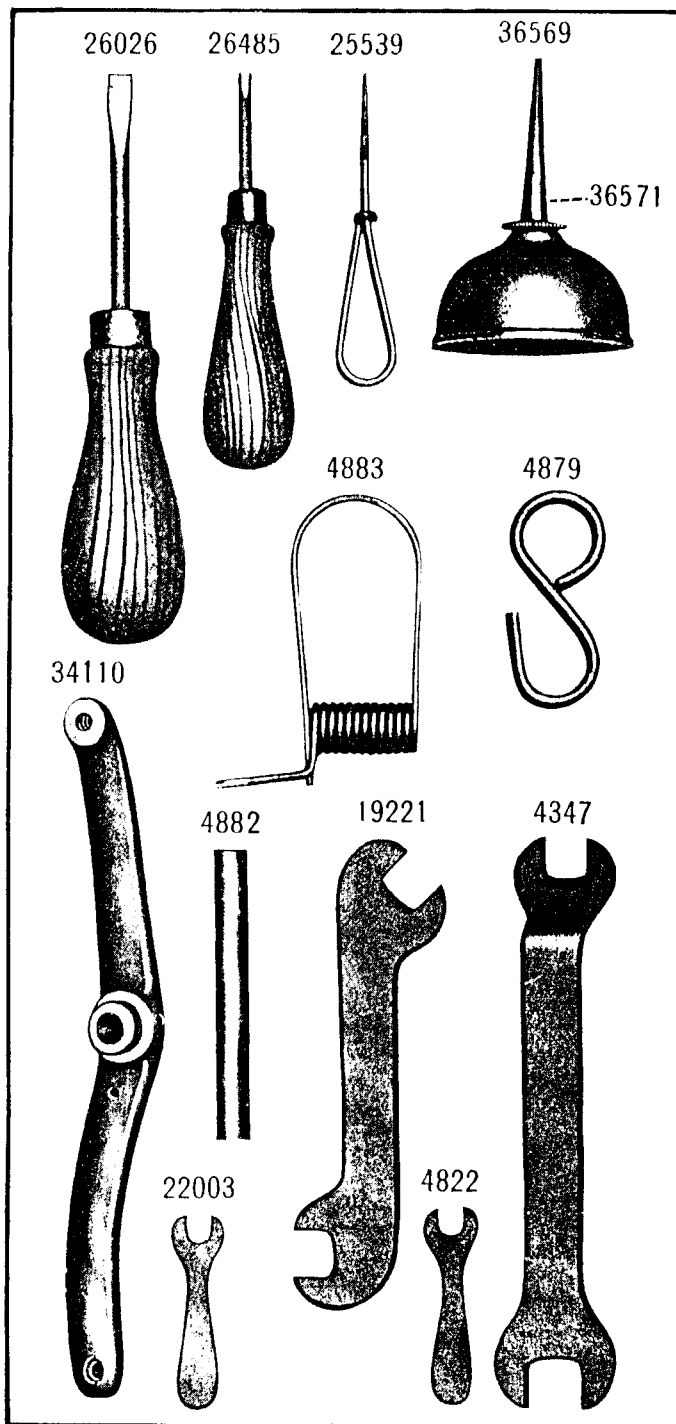

PLATE 4236—ONE-FOURTH SIZE

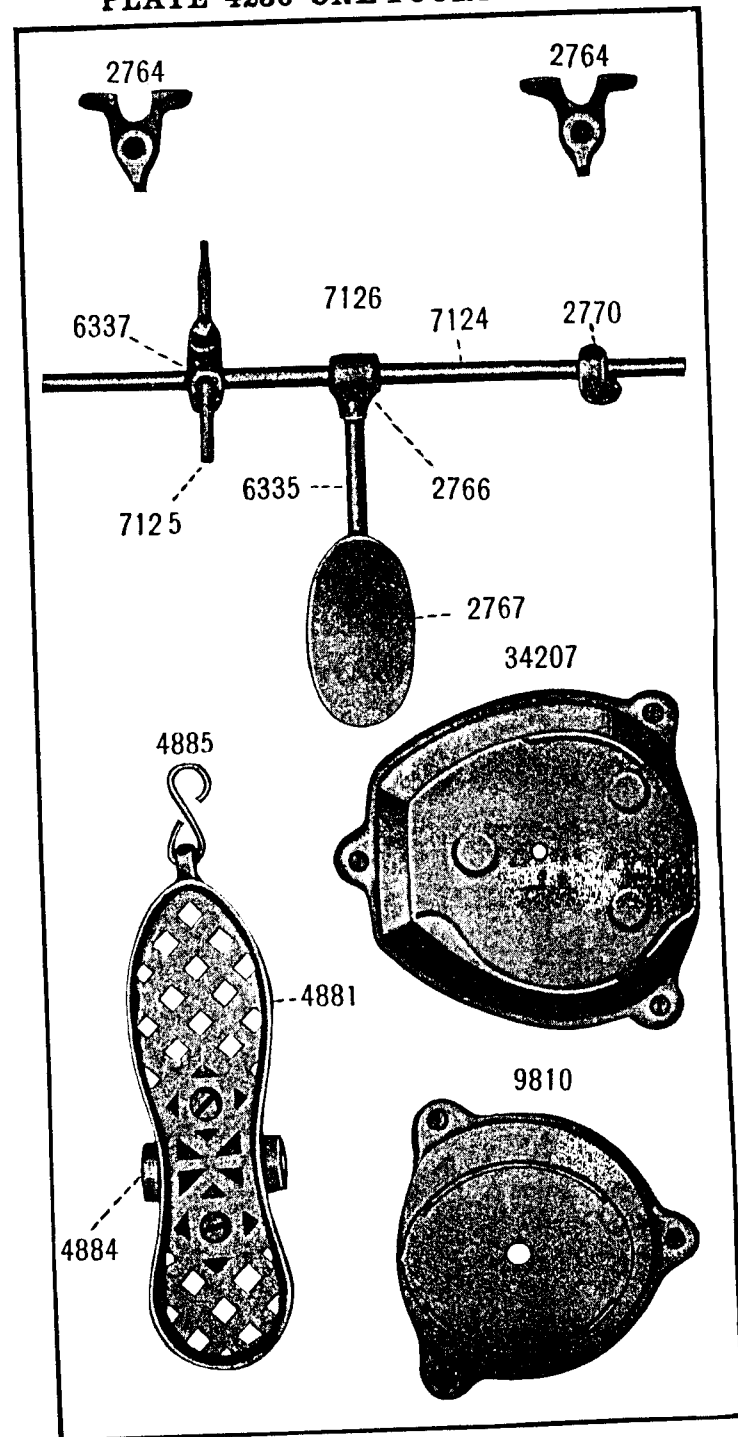

PLATE 4237—FULL SIZE

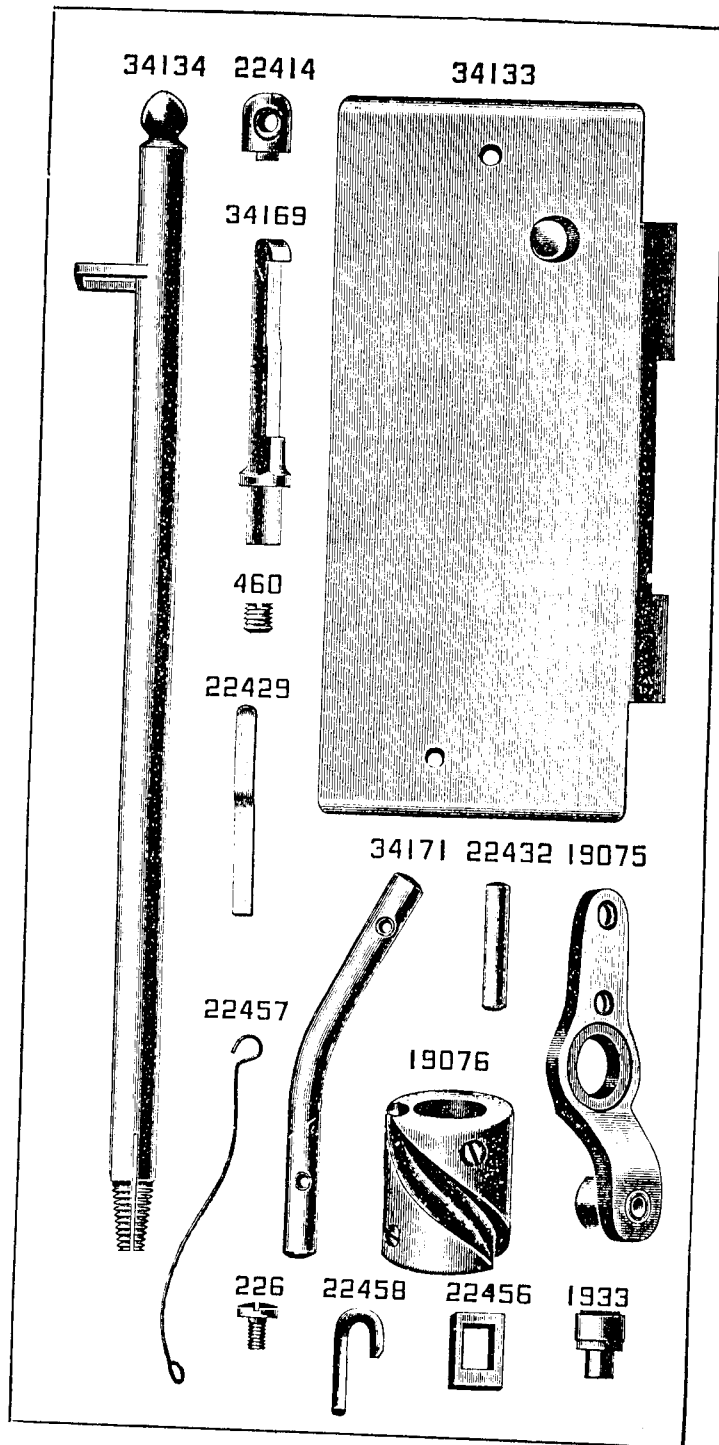

PLATE 4246—ONE-HALF SIZE

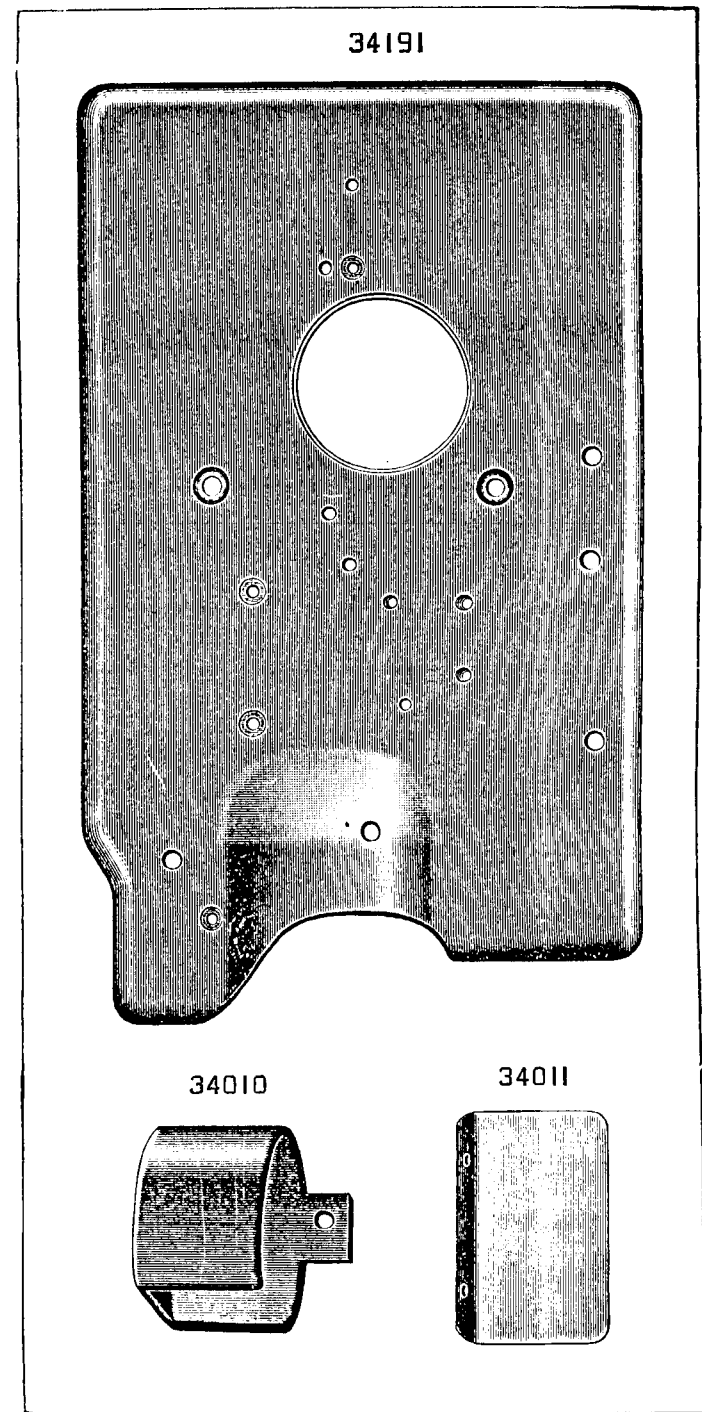

PLATE 4248—FULL SIZE

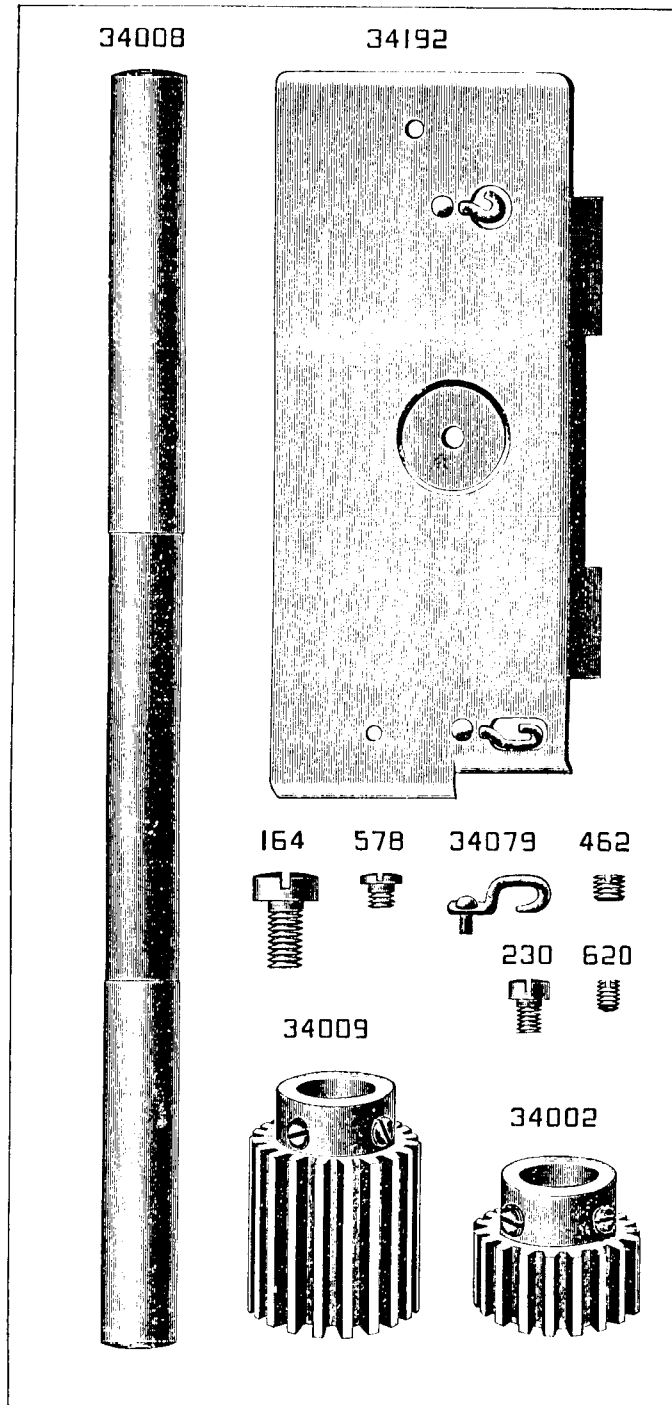

PLATE 6855—FULL SIZE

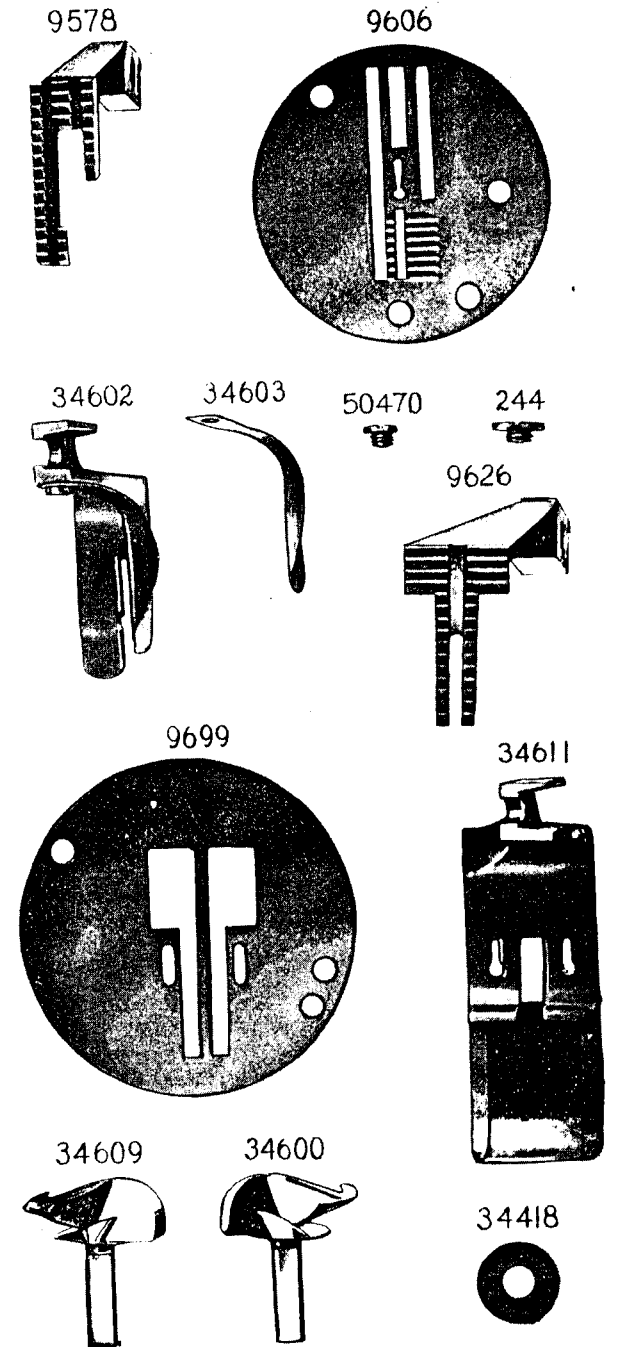

PLATE 6856—FULL SIZE

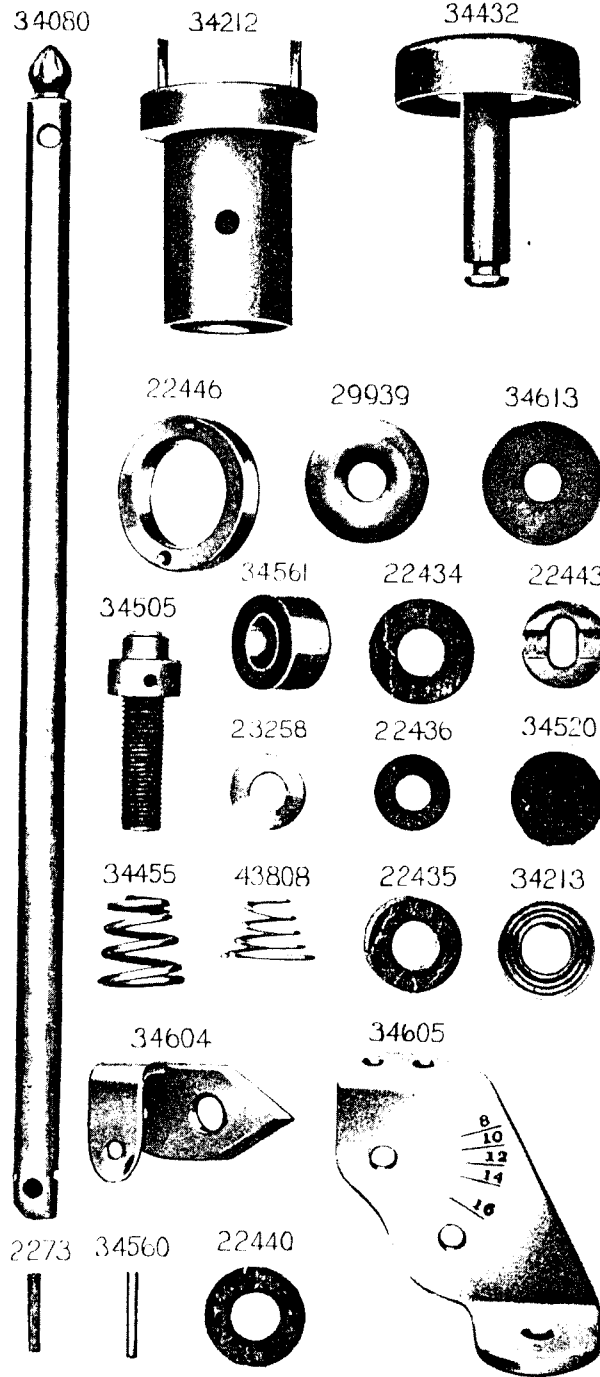

PLATE 6857—FULL SIZE

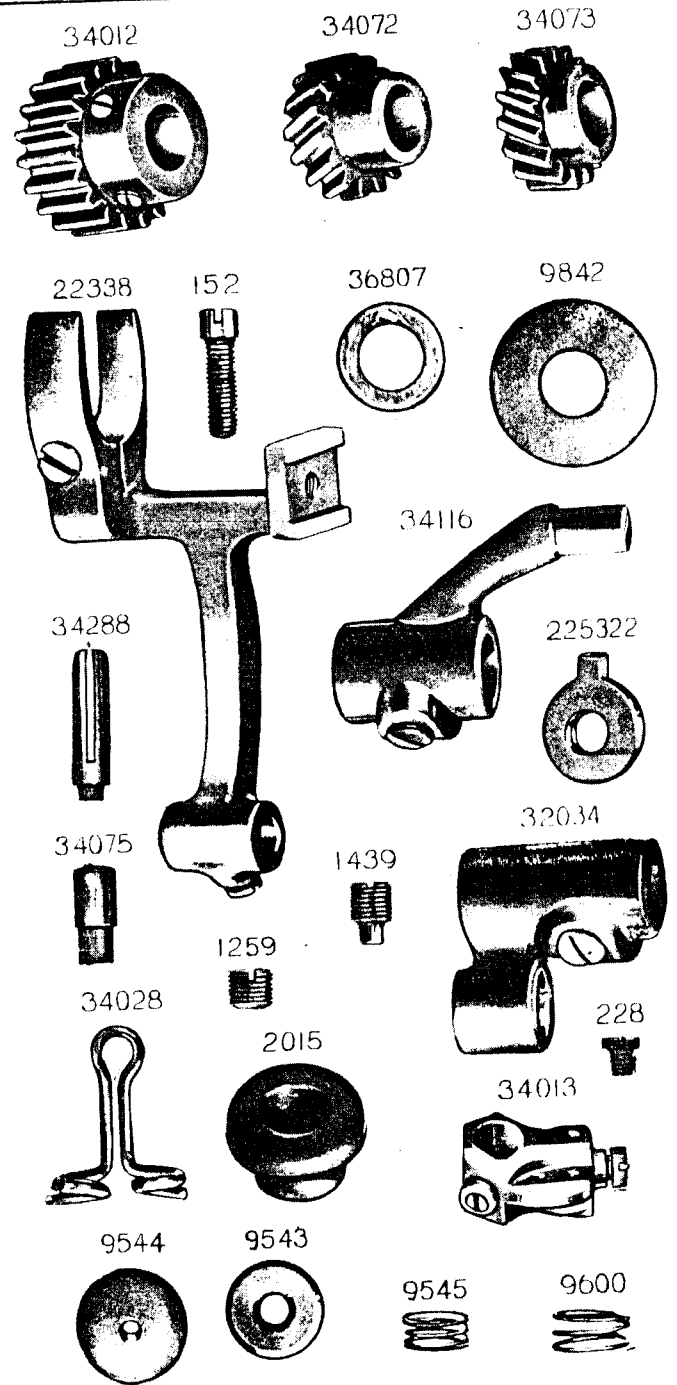

PLATE 6858—FULL SIZE

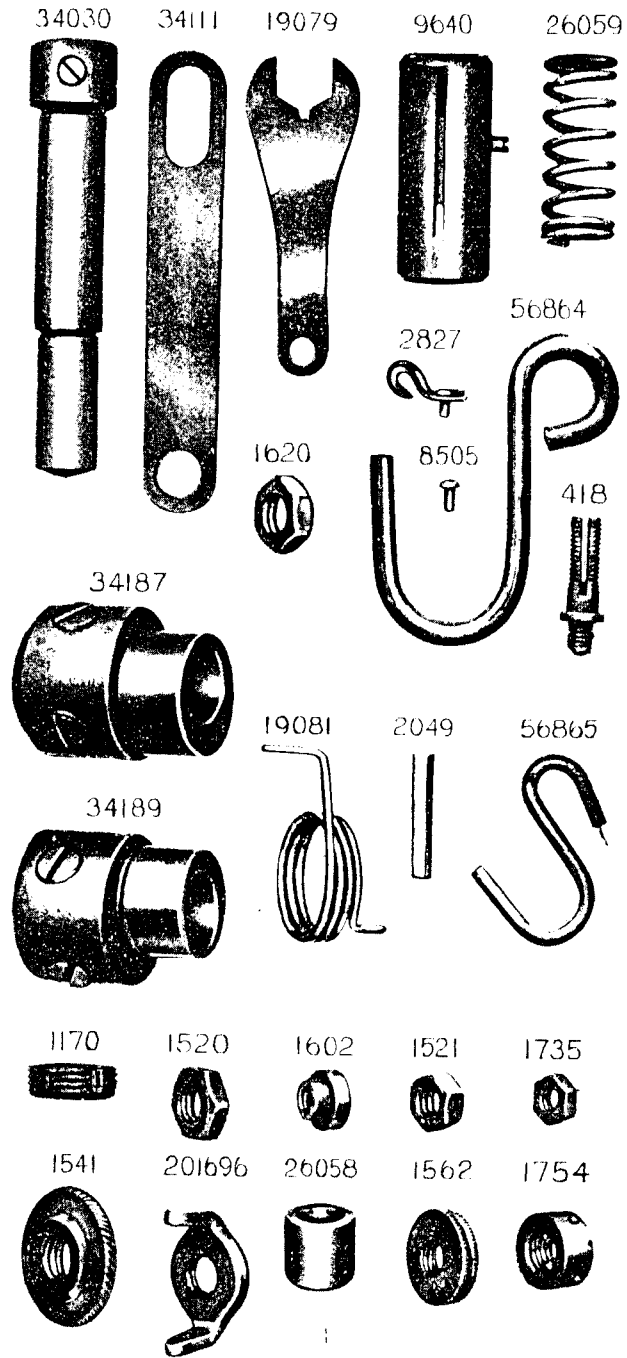

PLATE 6859—FULL SIZE

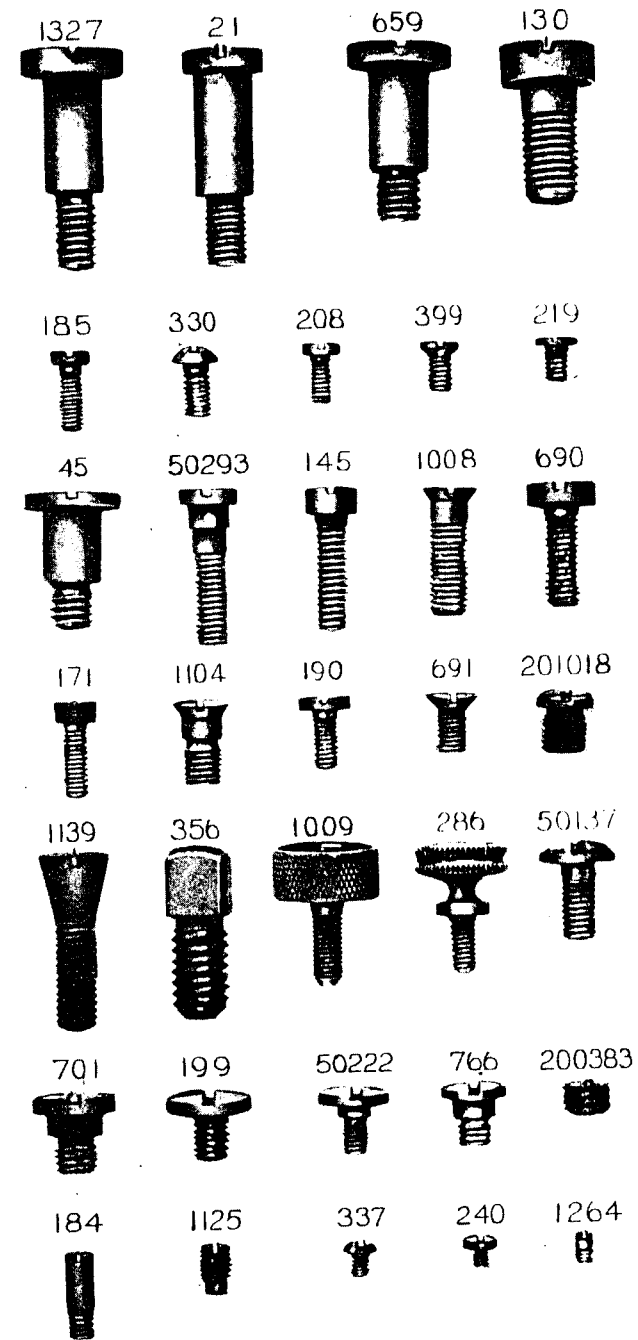
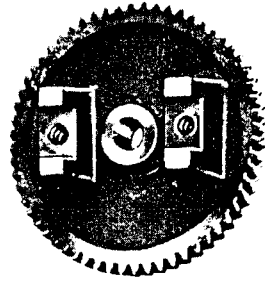
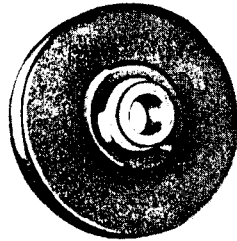

PLATE 6860—ONE-HALF SIZE

34619



34599



32026

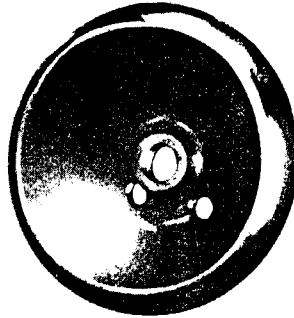

34608

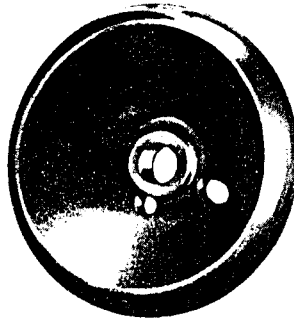

22449



9566

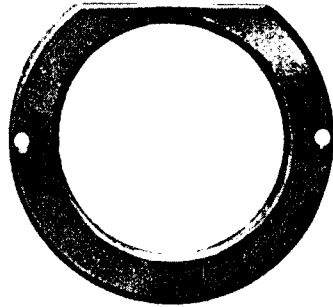

34311



35131

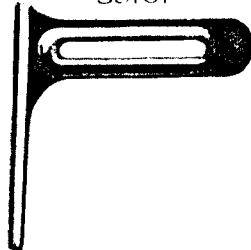

34287

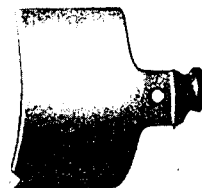

PLATE 6861—ONE-HALF SIZE

34235



34186



34589



34433



34617

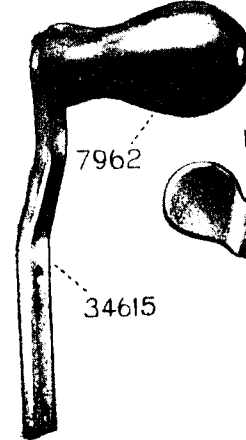

7962

34615

1152

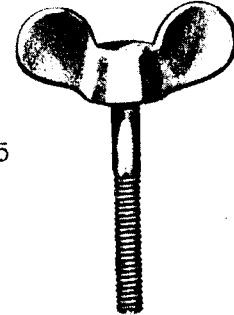

474

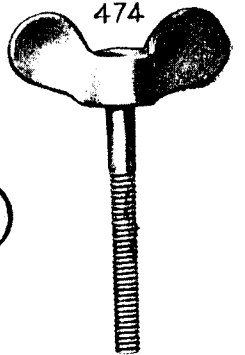
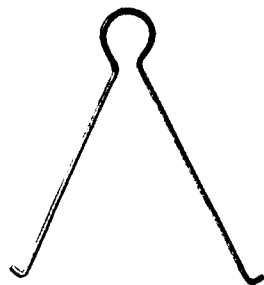

PLATE 6862—ONE-HALF SIZE

225324



225390



34137

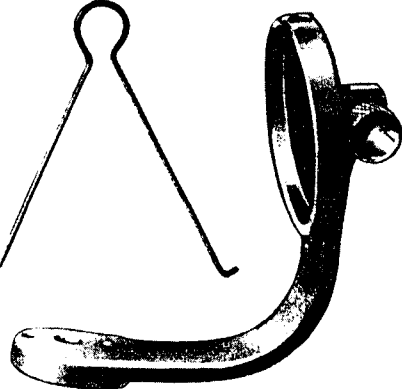

22348

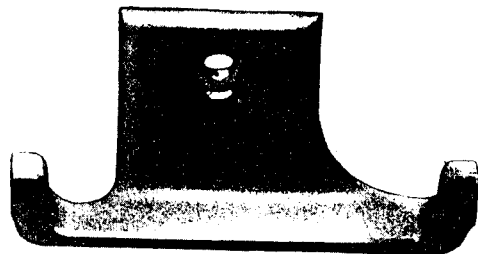

27739



225326



9843

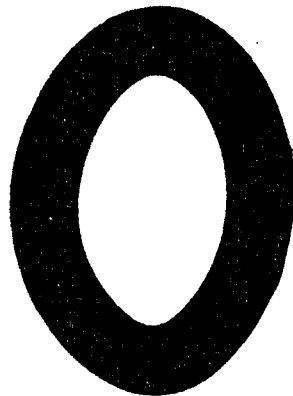

PLATE 6863—ONE-HALF SIZE

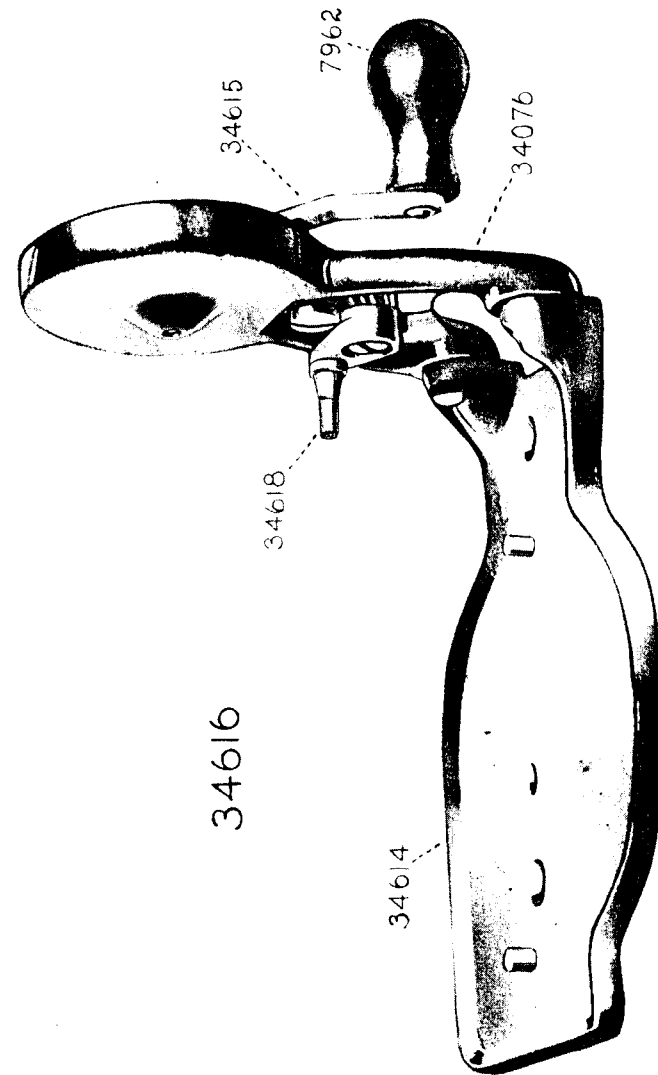

PLATE 6864—FULL SIZE

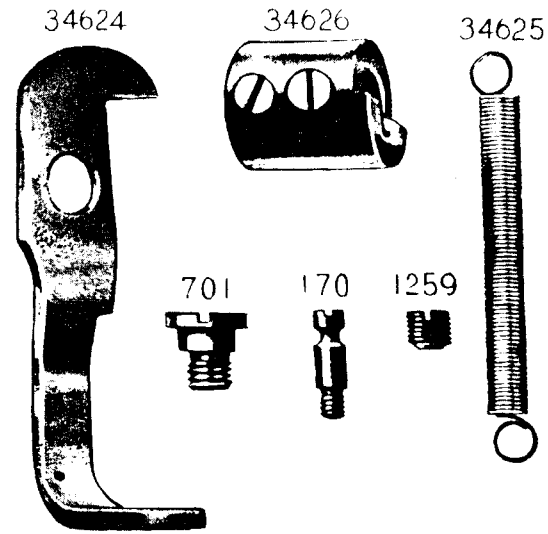

PLATE 7233—ONE-FOURTH SIZE

