

# PFAFF

## 1181

## 1183

Teileliste

Parts list

Lista de piezas

零件表

## 1181-D

## 1183-D

Diese Teileliste hat für Maschinen ab nachfolgender  
Seriennummer Gültigkeit:

This parts list applies to machines from the following  
serial numbers onwards:

Esta lista de piezas tiene validez para máquinas a partir del  
número de serie siguiente:

本零件表对从下列系列号起的机器有效:

# 6001000 →

Alle Informationen und Abbildungen waren zum Zeitpunkt der Druckgebung auf dem neusten Stand.

Technische Änderungen vorbehalten!

Der Nachdruck, die Vervielfältigung sowie die Übersetzung - auch auszugsweise - aus PFAFF-Teilelisten ist nur mit unserer vorherigen Zustimmung und mit der Quellenangabe gestattet.

At the time of printing, all information and illustrations contained in this document were up to date.

Subject to alteration!

The reprinting, copying or translation of PFAFF Parts lists whether in whole or in part, is only permitted with our previous permission and with written reference to the source.

Todas las informaciones e ilustraciones de este manual estaban al día en el momento de entregarse para su impresión.

¡ Salvo modificaciones técnicas!

La reimpresión, reproducción y traducción - aunque sólo sea parcial - de las listas de piezas PFAFF sólo está permitida con nuestro permiso previo e indicando la fuente.

所有信息和图片在付印时都是最新的。

保留技术更改的权力！

全部或部分翻印、复制以及翻译PFAFF-零件表  
必须事先经由我们同意并且注明来源。

## **PFAFF Industrie Maschinen AG**

Postfach 3020

D-67653 Kaiserslautern

Königstr. 154

D-67655 Kaiserslautern

	Seite Page Página 页
<b>0</b> <b>Wichtiger Hinweis</b> .....	0 - 1
Important note	
Observación importante	
重要提示	
<b>1</b> <b>Vorwort</b> .....	1 - 1
Foreword	
Notas preliminares	
前言	
<b>2</b> <b>Erläuterungen der Schlüsselzeichen</b> .....	2 - 1
Explanation of key markings	
Explicaciones de los signos clave	
标记说明	
<b>3</b> <b>Basismaschine</b>	
Basic machine	
Máquina básicas	
基础机器	
<b>3.01</b> <b>Gehäuseteile</b> .....	3 - 1
Housing sections	
Piezas del cárter	
机身零件	
<b>3.02</b> <b>Kopfteile</b> .....	3 - 2
Needle head parts	
Piezas de la cabeza	
机头零件	
<b>3.03</b> <b>Armteile</b> .....	3 - 6
Arm parts	
Piezas del brazo	
机臂零件	
<b>3.04</b> <b>Grundplattenteile</b> .....	3 - 12
Bedplate parts	
Piezas del cárter	
底板零件	
<b>4</b> <b>SRP</b> .....	4 - 1
SRP	
SRP	
SRP	
<b>5</b> <b>Kanten-Beschneideinrichtung (-731/01)</b> .....	5 - 1
Edge trimmer (-731/01)	
Recortador (-731/01)	
切边器 (-731/01)	

	Seite Page Página 页
<b>6</b> Fadenabschneid-Einrichtung (-900/24) ..... Thread trimmer (-900/24) Cortahilos (-900/24) 切线器 (-900/24)	6 - 1
<b>7</b> Fadenabstreif-Einrichtung (-909/04) ..... Thread wiper (-909/04) Retirahilos (-909/04) 拨线器 (-909/04)	7 - 1
<b>8</b> Presserfuß-Automatik (-910/06) ..... Automatic presser foot lifter (-910/06) Grupo acondicionador del aire comprimido (-910/06) 压脚自动提升器 (-910/06)	8 - 1
<b>9</b> Verriegelungs-Einrichtung (-911/37) ..... Backtacking mechanism (-911/37) Rematador (-911/37) 锁紧装置 (-911/37)	9 - 1
<b>10</b> Absaugeinrichtung (-920/06) ..... Vacuum waste disposal unit (-920/06) Dispositivo de aspiración (-920/06) 吹风装置 (-920/06)	10 - 1
<b>11</b> Spulenfadenvorratswächter (-926/06) ..... Bobbin thread supply monitor (-926/06) Detector del hilo de la canilla (-926/06) 底线余量监视器 (-926/06)	11 - 1
<b>12</b> Walzentransport-Einrichtung (-948/51) ..... Puller feed (-948/51) Puller (-948/51) 滚筒送料器 (-948/51)	12 - 1
<b>13</b> Elektrische Ausrüstung Electrical equipment Equipo eléctrico 电设备	
<b>13.01</b> Kabelbaum zum Oberteil ..... Cable tree to sewing head Mazo de cables para el cabezal 上部机器电缆束	13 - 1
<b>13.02</b> Tastschalter ..... Push-button Interruptor pulsador 按钮开关	13 - 2

	Seite Page Página 页
<b>13.03 Bedienfeld</b> .....	<b>13 - 3</b>
Control panel	
Panel de mandos	
操作板	
<b>13.04 Einbaumotor</b> .....	<b>13 - 5</b>
Built-in motor	
Motor incorporado	
内装式电机	
<b>13.05 Oberteilerkennung und Einschaltsperr</b> .....	<b>13 - 6</b>
Sewing head identification and start inhibitor	
Detección de la parte superior y bloqueo de arranque	
上部机器识别和起动机闭锁	
<b>13.06 Sollwertgeber</b> .....	<b>13 - 7</b>
Set-point generator	
Emisor del valor teórico	
给定值发生器	
<b>13.07 Motor-Hauptschalter</b> .....	<b>13 - 8</b>
Main switch	
Interruptor principal	
电机主开关	
<b>13.08 Knieaster mit Leitung</b> .....	<b>13 - 8</b>
Knee switch with cable	
Interruptor de rodillera con cable	
带电缆膝键	
<b>13.09 Steuerkasten</b> .....	<b>13 - 9</b>
Control box	
Caja de mandos	
控制箱	
<b>14</b> <b>Wartungseinheit</b> .....	<b>14 - 1</b>
Air filter / lubricator	
Grupo acondicionador del aire comprimido	
保养单元	
<b>15</b> <b>Garnrollenständer</b> .....	<b>15 - 1</b>
Reel stands	
Portacarretes	
线轴支架	
<b>16</b> <b>Einstellehren</b> .....	<b>16 - 1</b>
Adjustment gauges	
Calibres de ajuste	
设置量规	

	Seite Page Página 页
<b>17</b> Teile zur Tischplatte .....16 - 1 Parts for table top Piezas para el tablero 用于台板的零件	
<b>18</b> Keilriemen .....18 - 1 V-belt Correa trapezoidal 三角皮带	
<b>19</b> Knielüfterteile .....18 - 1 Knee lifter parts Piezas del alzaprensateles por rodillera 膝松线器零件	
<b>20</b> Anbausatz für externen Motor.....20 - 1 Mounting kit for external motor Juego de piezas acoplables para motor externo 外部电机安装组件	
<b>21</b> Schmiermittel-Übersicht .....21 - 1 Overview of lubricants Tabla de lubricantes 润滑剂一览	
<b>22</b> Index (Teilenummern / Seitenzahlen) .....22 - 1 Index (part numbers / page numbers) Index (números de pieza / números de página) 注脚(零件号/页号)	
<b>23</b> Unterklassen-Ausstattung Subclass parts Composición de las subclases 子机型-设备	
<b>23.01</b> Nähwerkzeuge (PFAFF 1181).....23 - 2 Gauge parts (PFAFF 1181) Organos de costura (PFAFF 1181) 缝纫工具	
<b>23.02</b> Nähwerkzeuge (PFAFF 1183).....23 - 5 Gauge parts (PFAFF 1183) Organos de costura (PFAFF 1183) 缝纫工具	

### Achtung!



Wir machen ausdrücklich darauf aufmerksam, daß Ersatz- und Zubehörteile, die nicht von uns geliefert werden, auch nicht von uns geprüft und freigegeben sind. Der Einbau und / oder die Verwendung solcher Produkte kann daher u. Umständen konstruktiv vorgegebene Eigenschaften Ihrer Maschine negativ verändern. Für Schäden, die durch die Verwendung von Nicht-Originalteilen entstehen, übernehmen wir keine Haftung!

### Caution!



We warn you expressively that spare parts and accessories that are not supplied by us are not tested and released by us. Fitting or using these products may therefore have negative influences on features that depend on the machine design. We are not liable for any damage caused by the use of non-Pfaff parts!

### ¡Atención!



Se hace observar que en el caso de piezas de recambio y accesorios que no hayan sido suministrados por nosotros, quiere decir que non han sido sometidas por nuestra parte a un control y que no se les ha dado el visto bueno. Por esta razón, el montaje y/o empleo de tales productos puede repercutir negativamente en las características previstas en su máquina. ¡Para los daños que eventualmente pudiesen presentarse al utilizar piezas no originales, no asumimos ninguna garantía!

### 注意!



我们必须明确指出，所有不是由我们供货的备件和附件都未经我们检查，也没有被我们批准使用。装入和/或使用这些产品可能在一定的情况下会对机器的设计特性造成负面改变。对由于使用非原装件所造成的损失，我们不负任何责任!

- Die Seriennummer der Maschine, für die diese Teileliste Gültigkeit hat, ist auf der Titelseite aufgeführt.
  - Alle Teile sind so abgebildet, wie sie in der Maschine funktionsmäßig zusammengehören.
  - Gestrichelt dargestellte Teile zeigen angrenzende Teile aus anderen Funktionsgruppen.
  - Im oberen Teil der Bildseiten befindet sich eine Gesamtansicht der Maschine .
  - Der Einbauort der dargestellten Teile wird durch eine gerasterte Fläche gekennzeichnet.
  - Einrahmungen auf den Bildseiten zeigen, aus welchen Einzelteilen sich die Gruppenteile zusammensetzen.
  - Die auf den Bildseiten verwendeten Schlüsselzeichen (  ;  2 ;  3 usw.) sind im Kapitel "Erläuterungen der Schlüsselzeichen" aufgelistet.
- 
- The serial number of the machine to which this parts list applies is indicated on the cover page.
  - All parts are illustrated in function groups with the parts which they function together with in the machine.
  - Parts illustrated with broken lines are parts from other function groups which border on the illustrated function group.
  - The above section of the page of illustrations contains a total view of the machine. The place for the installation of the parts pictured here is marked by the grid.
  - The framed-in sections on the illustration pages show the individual parts comprising a group.
  - The key markings used on the illustrated pages (  ;  2 ;  3 etc.) are listed in the chapter "Explanation of key markings".
- 
- El número de serie de la máquina para la cual tiene validez esta lista de piezas va indicado en la página de título.
  - Todas las piezas están ilustradas tal como aparecen en la máquina para su funcionamiento.
  - Las piezas representadas con rayitas muestran piezas colindantes de otros grupos de funciones.
  - En la parte superior de las páginas ilustradas se puede ver una vista en conjunto de la máquina.
  - El lugar de montaje de la pieza representada va caracterizada mediante una superficie reticulada.
  - Los recuadros en las páginas ilustradas indican las piezas individuales de que se componen los grupos.
  - Los signos clave (  ;  2 ;  3 etc.) empleados en las páginas con ilustraciones van listados en el capítulo "Explicaciones de los signos clave".
- 
- 适用于本零件表的机器系列号列在首页上。
  - 所有的零件都按照其在机器中的功能情况合在一起表达。
  - 用虚线表示的零件为相邻功能组中的零件。
  - 图的上部为机器全景。
  - 所示零件的安装部位用影格面表示。
  - 页上的框表示这套组件都由哪些零件所组成。
  - 图页上所使用的标记 (  ;  2 ;  3 等) 列表在“标记说明”中。



- [ ]** Unterklassenabhängig, Teilenummer siehe Unterklassen-Ausstattung.  
Subclas-dependent, for part number see subclass parts listing.  
Dependientes de la subclase, para el número de pieza véase "Dotación de subclases".  
取决于子机型，零件号见子机型设备。
- A** **Maschinen-Ausstattung für feine Materialien.**  
Model A for sewing thin and light-weight materials.  
Tipo A para materiales ligeros.  
用于薄料的机器设备。
- B** **Maschinen-Ausstattung für mittlere Materialien.**  
Model B for sewing thin and medium-weight materials.  
Tipo B para materiales semiligeros.  
用于中厚料的机器设备。
- C** **Maschinen-Ausstattung für mittelschwere Materialien.**  
Model C for sewing medium-heavy materials.  
Tipo C para materiales semipesados.  
用于中偏厚料的机器设备。
- N** **Stichlänge 6,0 mm.**  
Stitch lenght 6.0 mm.  
Largo de puntada 6,0 mm  
针距6.0 mm。
- 3/3** **Selbstklebende Folie**  
Self-adhesive foil  
Hoja autoadhesiva  
自粘式薄膜
- 3/4** **Selbstklebend**  
Self-adhesive  
Autoadhesivo  
自粘的
- 6** **Nadeldicke und Spitzenform bei Bestellung angeben.**  
Needle size and style of point to be stated on order.  
Grosor de aguja y forma de la punta, indíquese en los pedidos.  
在订货时给出针厚和针尖型式。
- 27/5** **Eingeklammerte Zahl = Länge in mm.**  
Number in brackets = length in mm.  
Cifra entre paréntesis = largura en mm.  
被括起的数字=长度，单位mm。

- 27/12**      **Eingeklammerte Zahl = Durchmesser x breite in mm.**  
Number in brackets = diameter x width in mm.  
Cifra entre paréntesis = diámetro x anchura en mm.  
被括起的数字=直径 x 宽度, 单位 mm。
- 28**            **Sonderausführung**  
Special version  
Tipo especial  
特殊款式
- 38/7**           **Kunststoffbeschichtet**  
Plastic-coated  
Con revestimiento de plástico  
塑料涂层的
- 40/3**           **Fetten mit 28-011 202-47; Bestellnummer siehe Seite 21 - 1.**  
Grease with 28-011 202-47; for part number see page 21 - 1.  
Engrase con grasa 28-011 202-47; para el número de pedido véase la página 21 - 1.  
上脂用 28-011 202-47; 订货号见 21 - 1页。
- 40/13**          **Fetten mit 28-011 202-05; Bestellnummer siehe Seite 21 - 1.**  
Grease with 28-011 202-05; for part number see page 21 - 1.  
Graisser avec de la graisse 28-011 202-05; n° de commande, voir page 21 - 1.  
上脂用 28-011 202-05; 订货号见 21 - 1页。
- 40/24**          **Ölen mit 28-011 201-05; Bestellnummer siehe Seite 21 - 1.**  
Oil with 28-011 201-05; for part number see page 21 - 1.  
Lubrifique con grasa 28-011 201-05; para el número de pedido véase la página 21 - 1.  
上油用 28-011 201-05; 订货号见 21 - 1页。
- 40/26**          **Füllen mit 28-011 201-05; Bestellnummer siehe Seite 21 - 1.**  
Top up with 28-011 201-05; for part number see page 21 - 1.  
Rellene con 28-011 201-05; para el número de pedido véase la página 21 - 1.  
注油用 28-011 201-05; 订货号见 21 - 1页。
- 40/27**          **Tränken mit 28-011 201-05; Bestellnummer siehe Seite 21 - 1.**  
Grease with 28-011 201-05; for part number see page 21 - 1.  
Engrase con grasa 28-011 201-05; para el número de pedido véase la página 21 - 1.  
浸油用 28-011 201-05; 订货号见 21 - 1
- 90/1**           **Für Wechselstrom**  
For single-phase A.C.  
Para corriente alterna monofásica  
适用于交流电

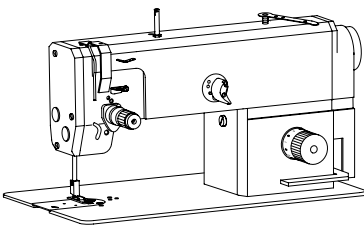

Gehäuseteile  
Housing sections  
Piezas del cárter  
机身零件

PFAFF 1181;1181- D  
PFAFF 1183;1183- D

3.01

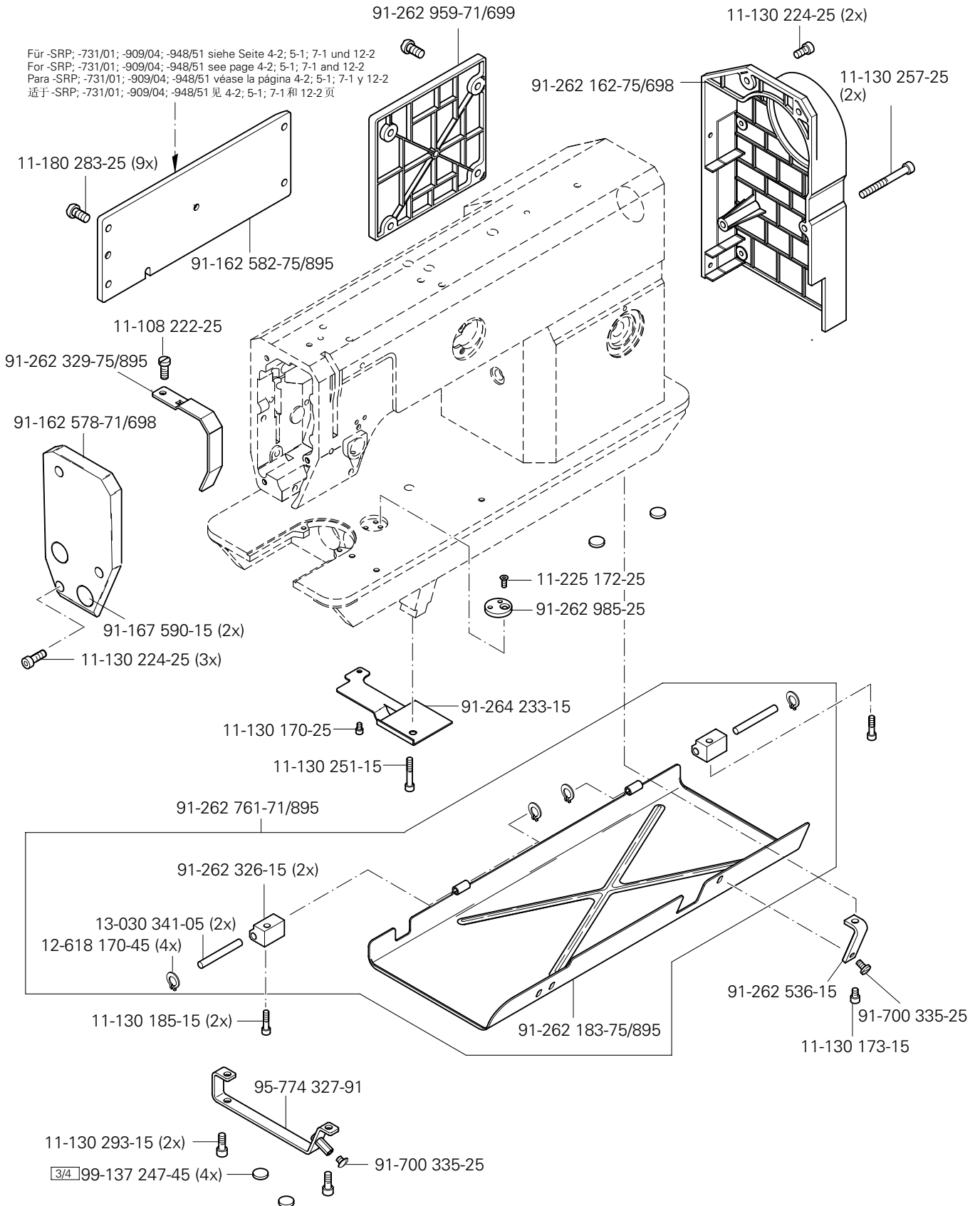

# 3.02

## Kopfteile Needle head parts Piezas de la cabeza 机头零件

PFAFF 1181;1181- D  
PFAFF 1183;1183- D

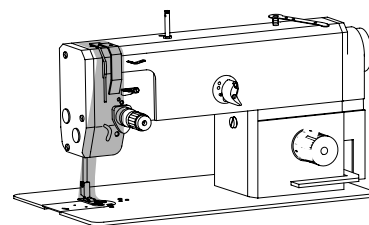

Für -909/04; -948/51 siehe Seite 7-1 und 12-1  
For -909/04; -948/51 see page 7-1 and 12-1  
Para -909/04; -948/51 véase la página 7-1 y 12-1  
适于 -909/04; -948/51 见 7-1 和 12-1 页

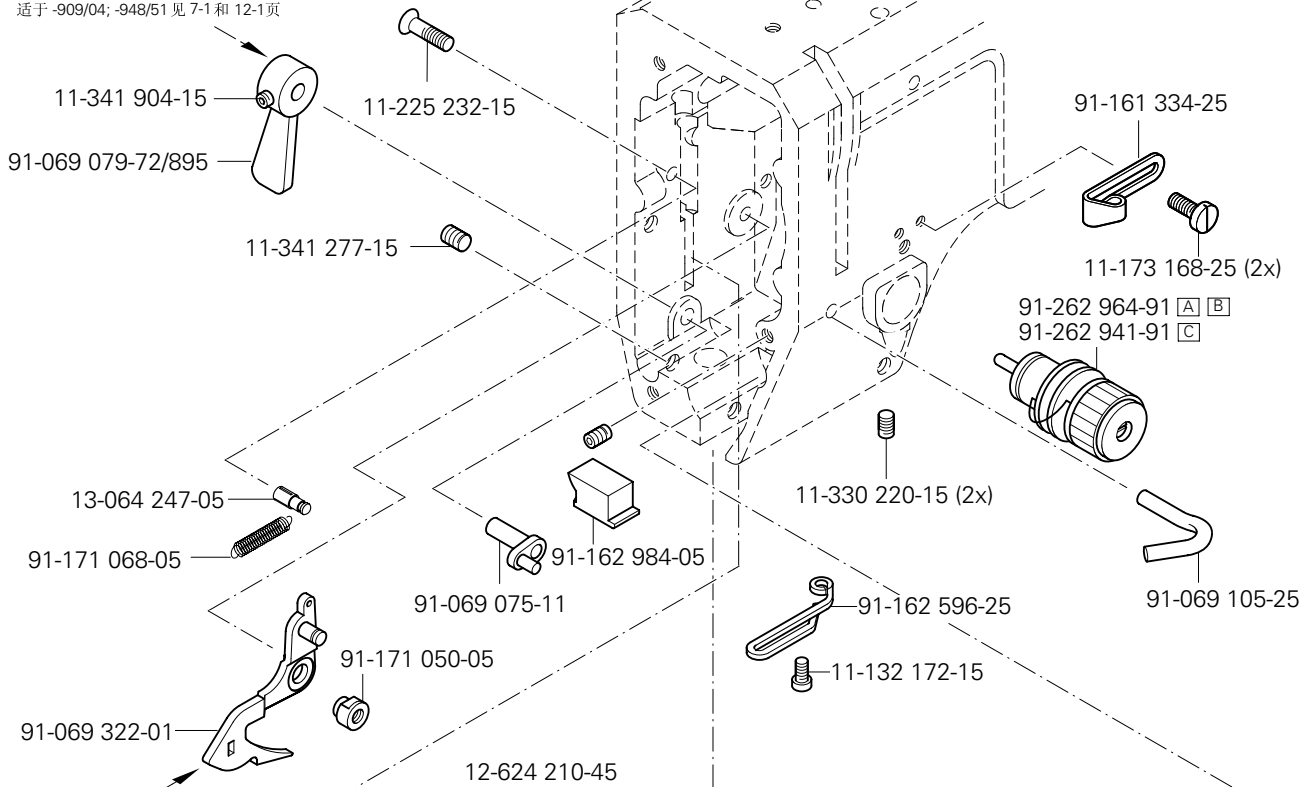

Für -SRP; -900/24 siehe Seite 4-1 und 6-1  
For -SRP; -900/24 see page 4-1 and 6-1  
Para -SRP; -900/24 véase la página 4-1 y 6-1  
适于 -SRP; -900/24 见 4-1 和 6-1 页

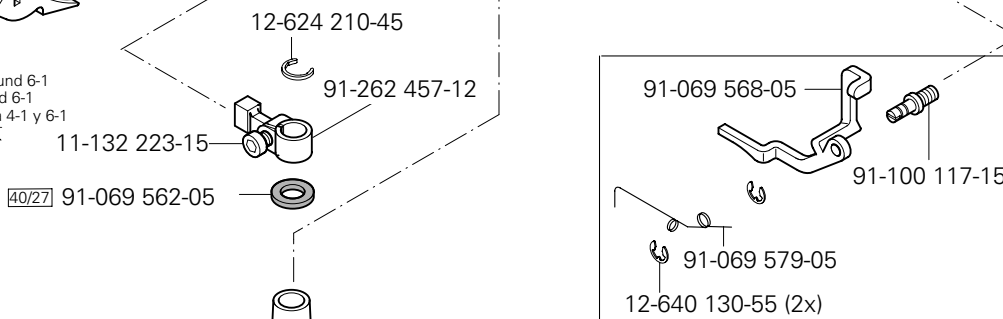

Für -8/44; -948/51 siehe Seite 12-2 und 23-6  
For -8/44; -948/51 see page 12-2 and 23-6  
Para -8/44; -948/51 véase la página 12-2 y 23-6  
适于 -8/44; -948/51 见 12-2 和 23-6 页

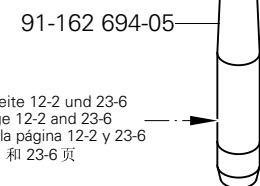

Für -8/44; -948/51 siehe Seite 12-2 und 23-6  
For -8/44; -948/51 see page 12-2 and 23-6  
Para -8/44; -948/51 véase la página 12-2 y 23-6  
适于 -8/44; -948/51 见 12-2 和 23-6 页

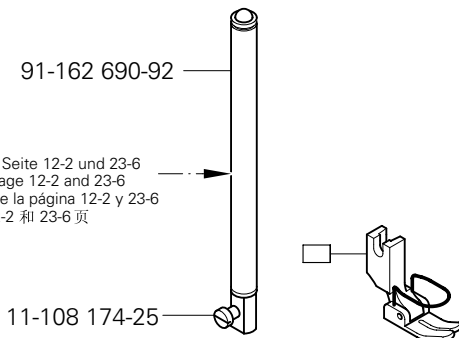

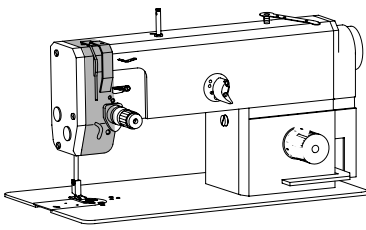

Kopfteile  
Needle head parts  
Piezas de la cabeza  
机头零件

PFAFF 1181;1181- D  
PFAFF 1183;1183- D

3.02

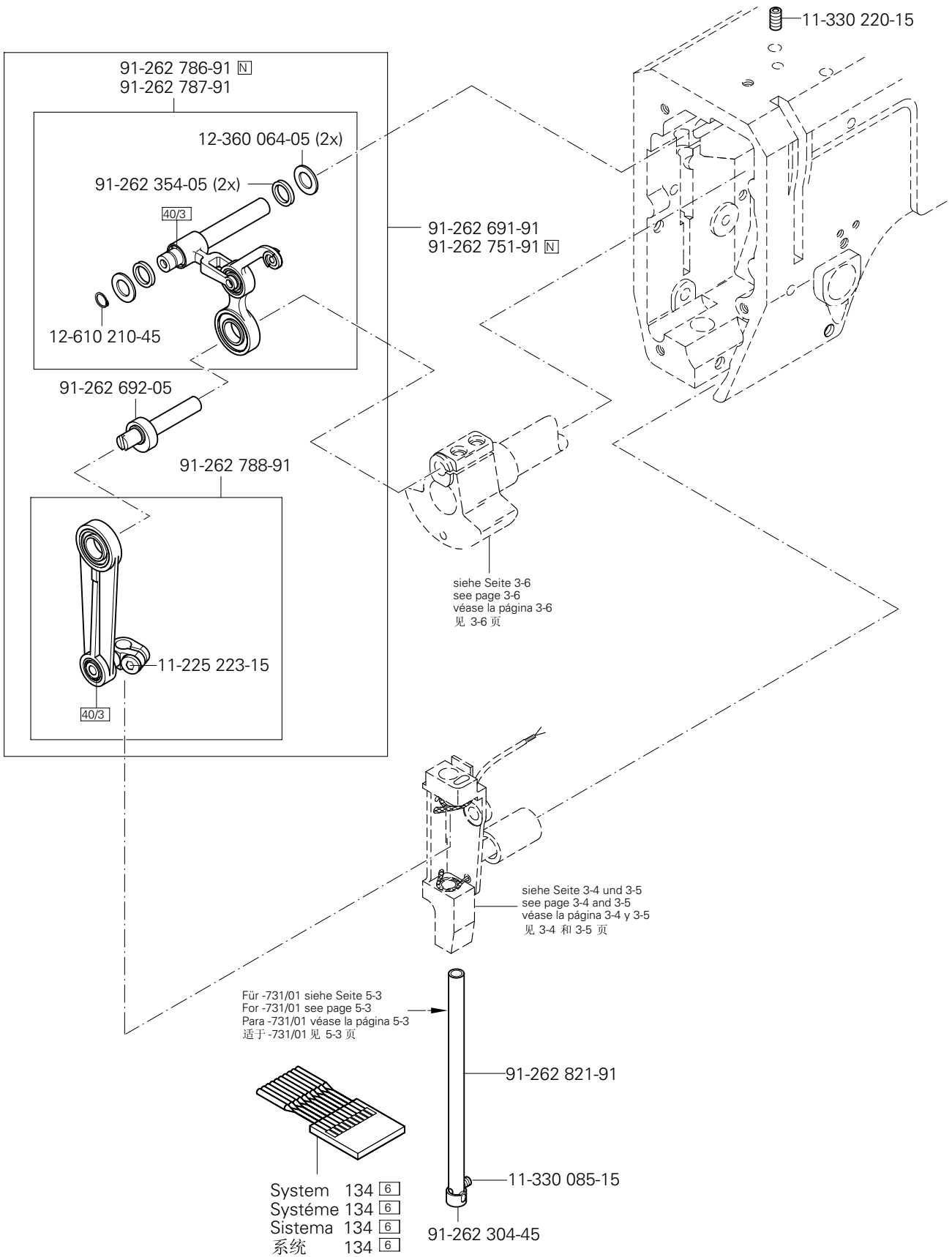

# 3.02

Kopfteile  
Needle head parts  
Piezas de la cabeza  
机头零件

PFAFF 1181;1181-D

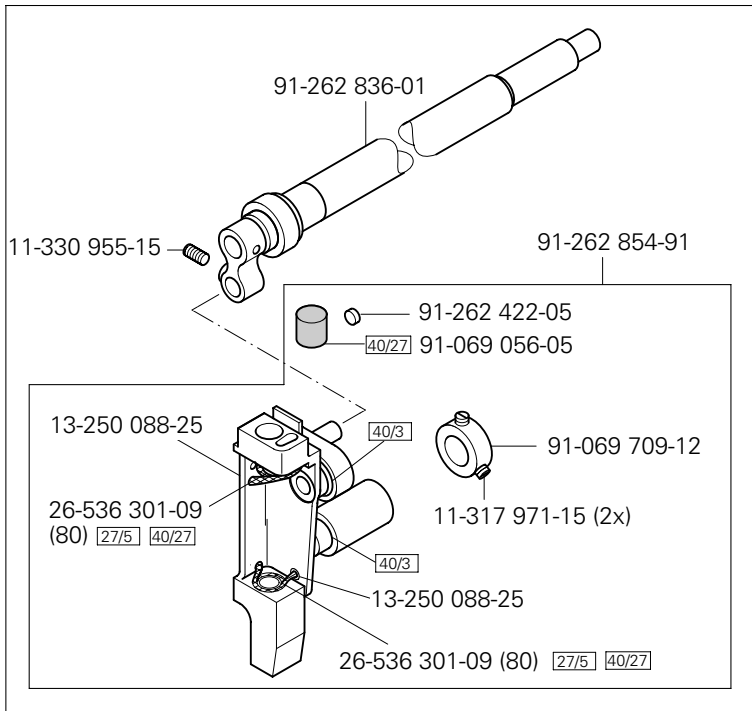
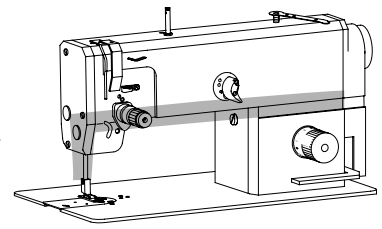

91-262 551-91 (PFAFF 1181-D)

siehe Seite 3-8  
see page 3-8  
véase la página 3-8  
见 3-8 页

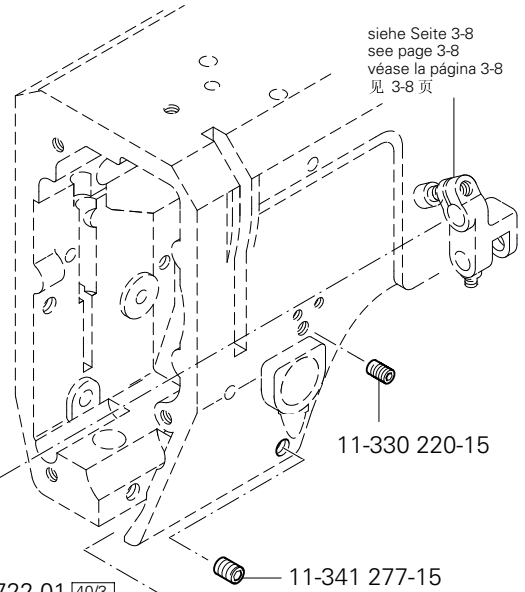

91-262 336-91 (PFAFF 1181)

11-341 901-15

99-133 220-01 (40/3)



99-069 722-01 (40/3)

91-169 457-12

11-330 220-15

11-341 277-15

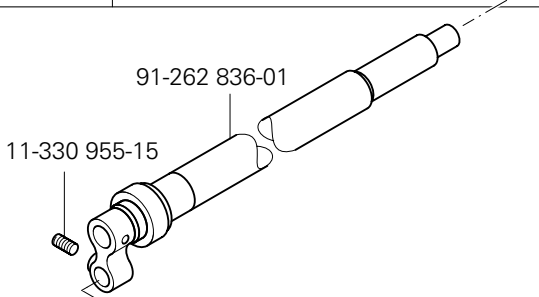

Anschluß siehe Seite 3-19  
For connection see page 3-19  
Para la conexión, véase la pág. 3-19  
接口见 3-19 页

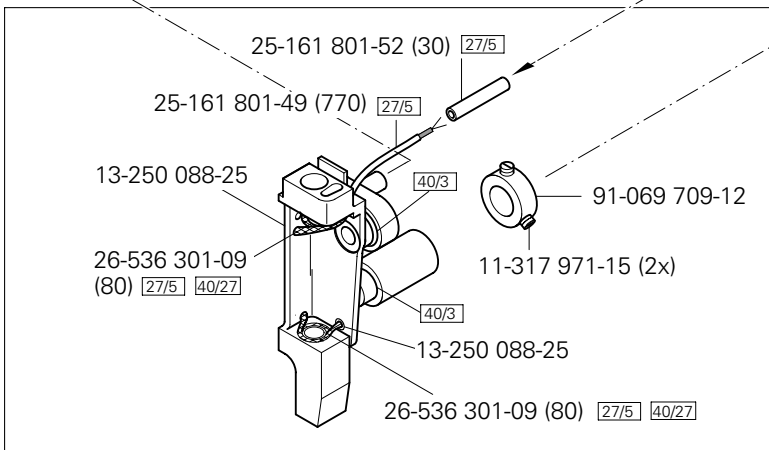

91-262 837-91

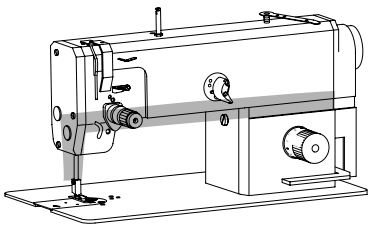

Kopfteile  
Needle head parts  
Piezas de la cabeza  
机头零件

PFAFF 1183;1183- D

3.02

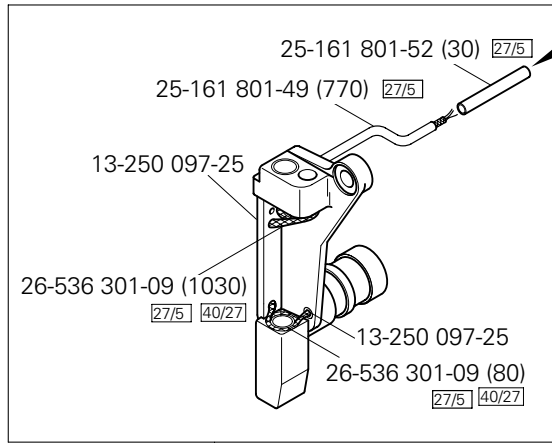

91-262 320-91 (PFAFF 1183)

Anschluß siehe Seite 3-19  
For connection see page 3-19  
Para la conexión, véase la pág. 3-19  
接口见 3-19 页

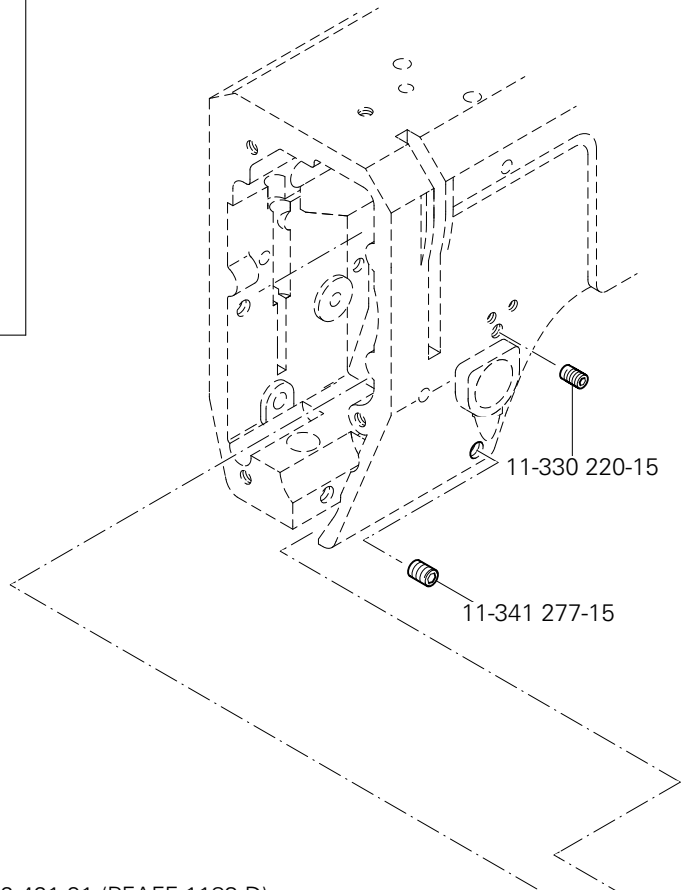

siehe Seite 3-3  
see page 3-3  
véase la página 3-3  
见 3-3 页

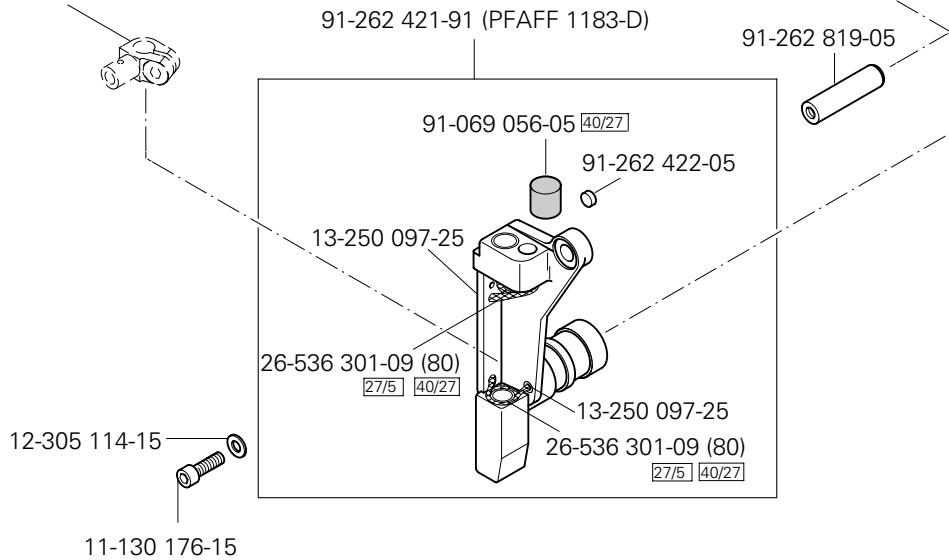

# 3.03

Armteile  
 Arm parts  
 Piezas del brazo  
 机臂零件

PFAFF 1181;1181- D  
 PFAFF 1183;1183- D

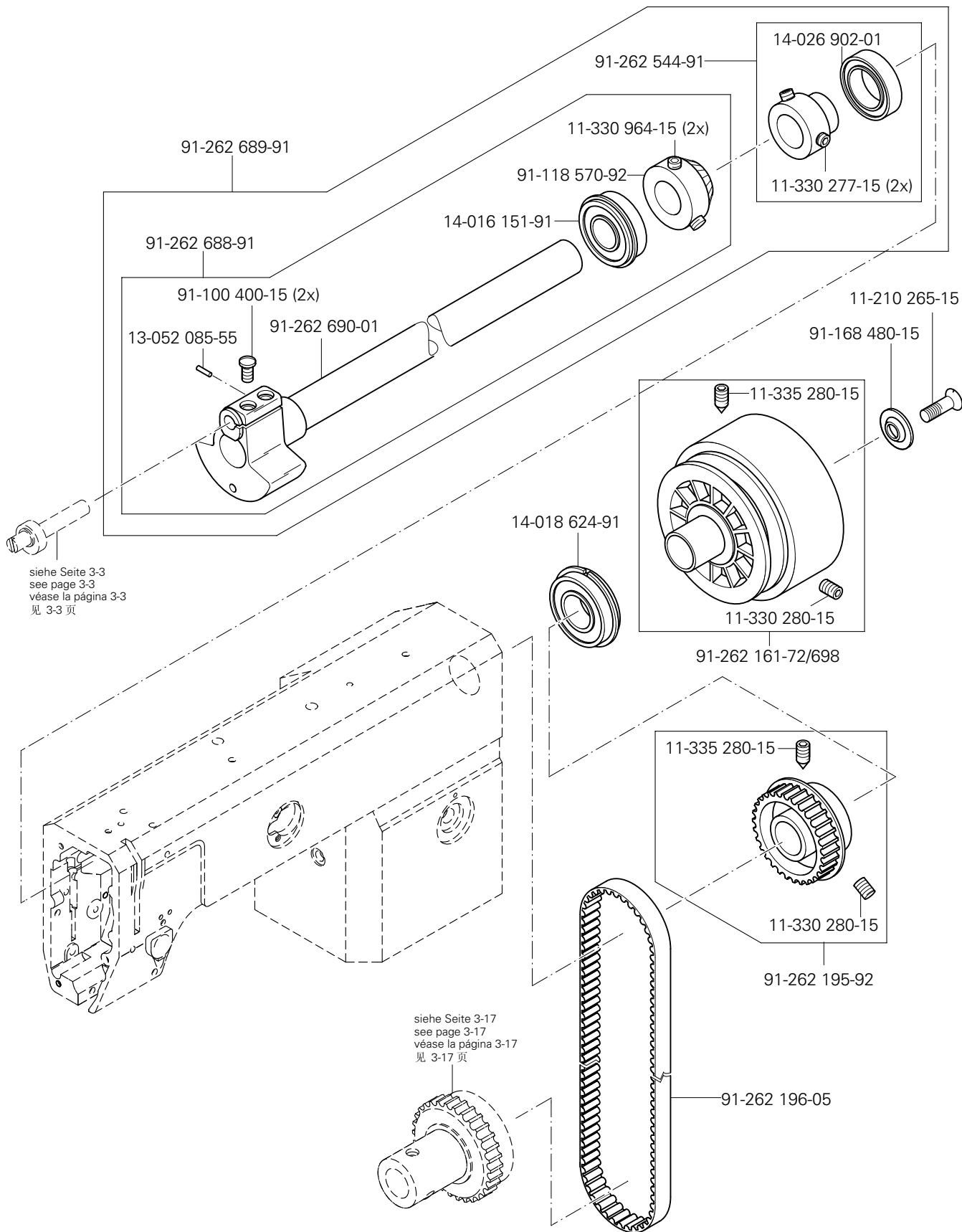
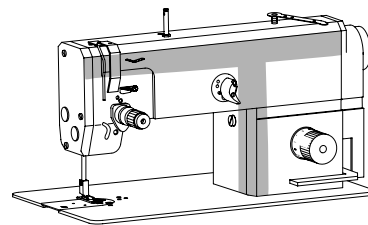



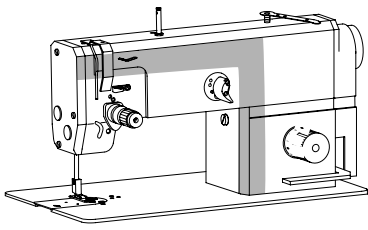

Armteile  
 Arm parts  
 Piezas del brazo  
 机臂零件

PFAFF 1181;1181- D  
 PFAFF 1183;1183- D

# 3.03

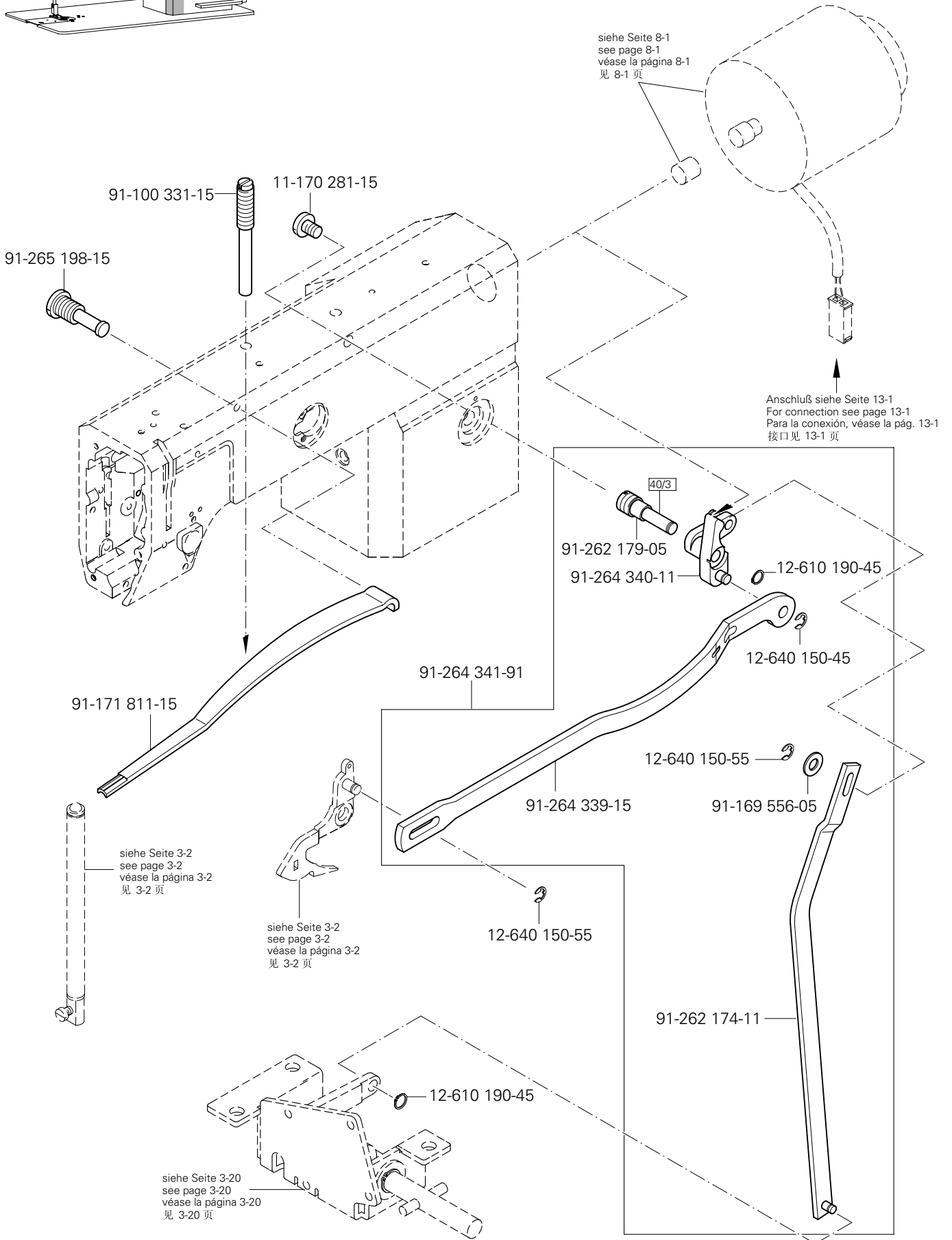

# 3.03

Armteile  
 Arm parts  
 Piezas del brazo  
 机臂零件

PFAFF 1181;1181- D

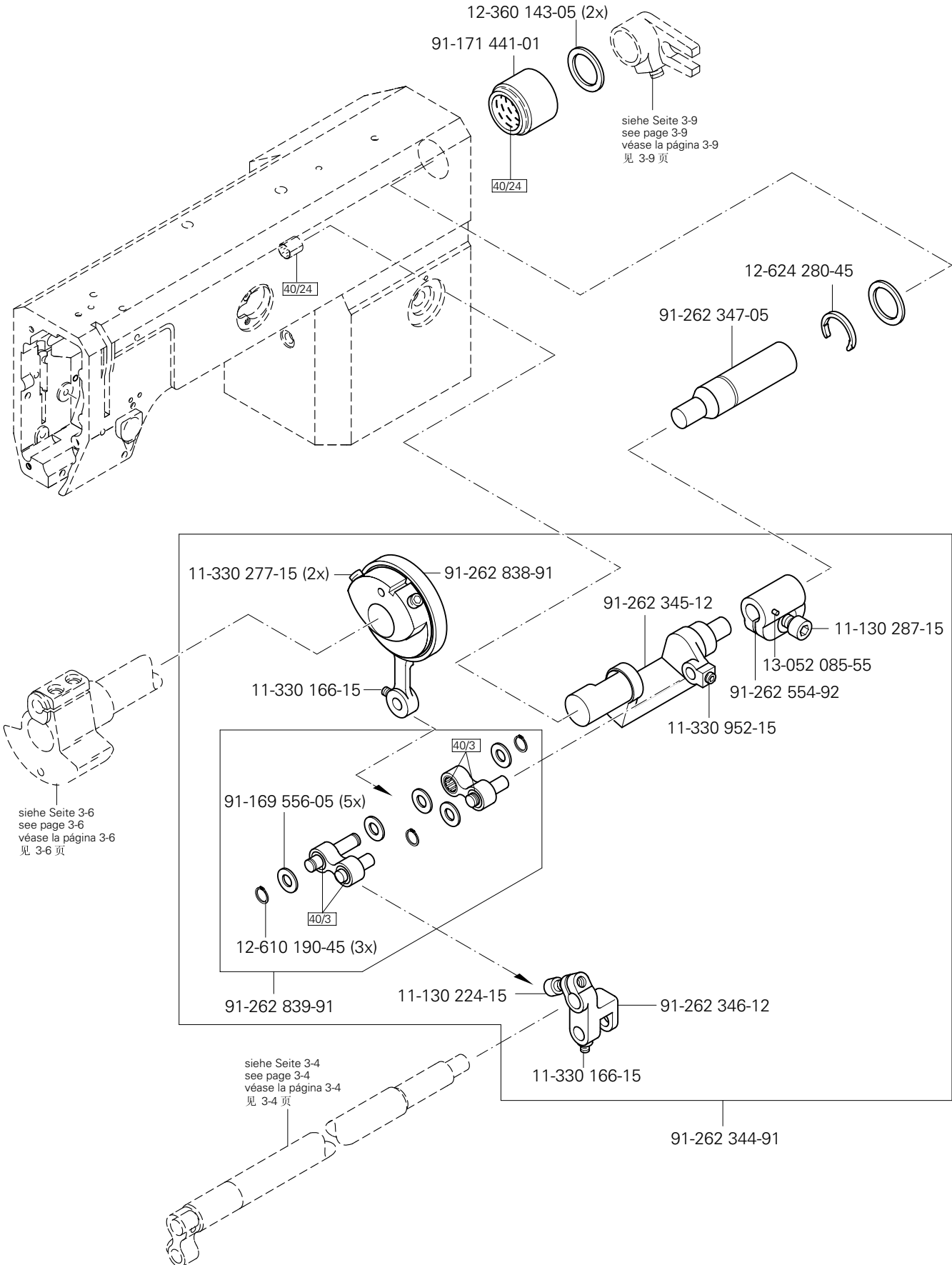
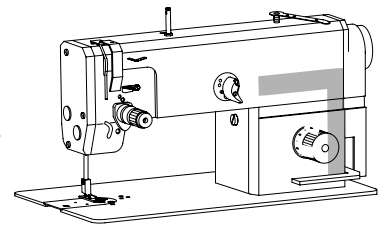

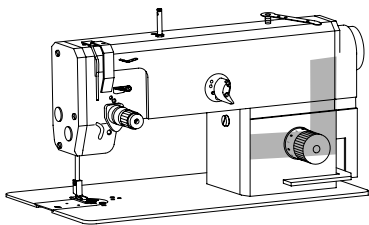

Armteile  
 Arm parts  
 Piezas del brazo  
 机臂零件

PFAFF 1181;1181- D

3.03

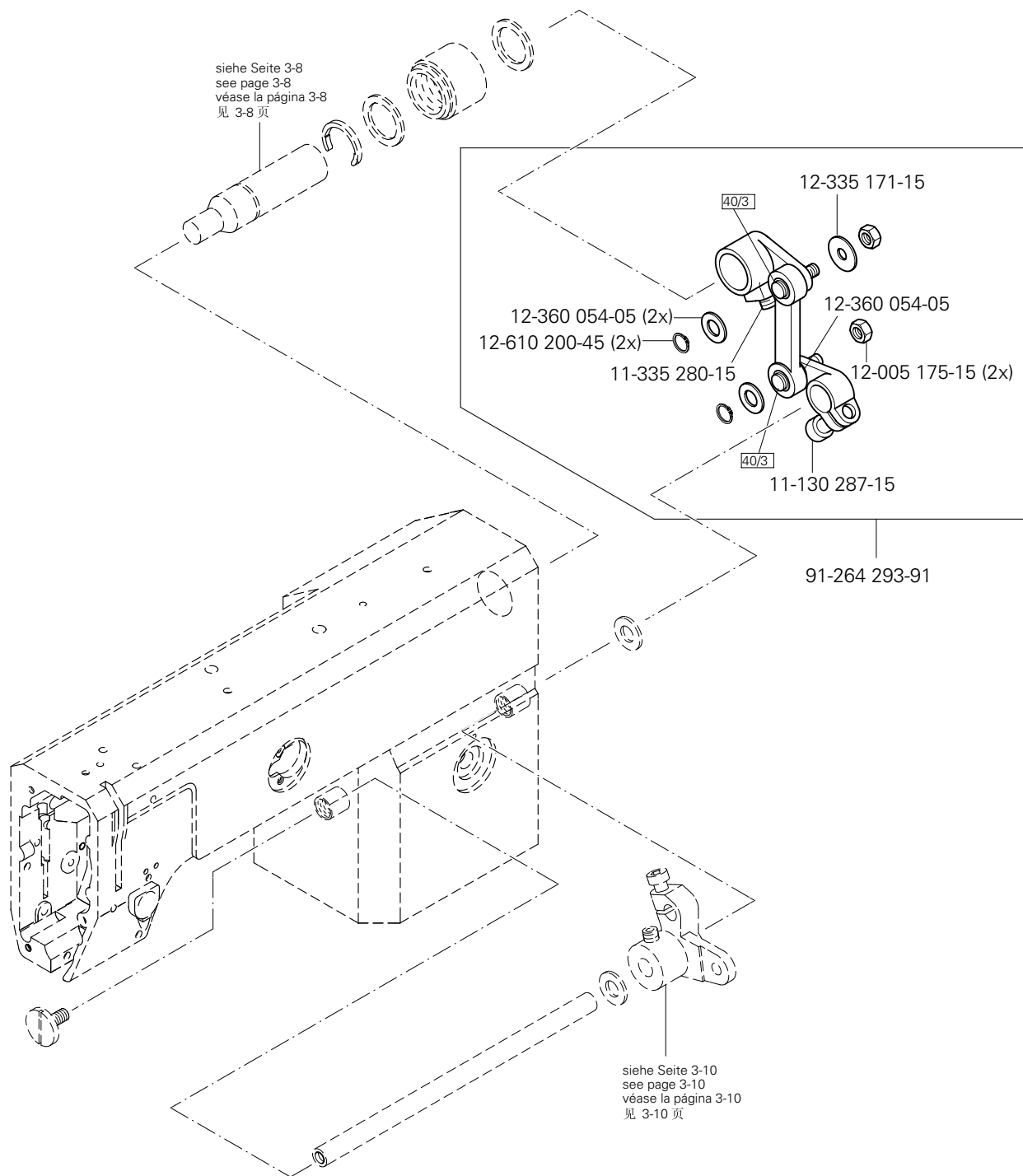

# 3.03

Armteile  
 Arm parts  
 Piezas del brazo  
 机臂零件

PFAFF 1181;1181- D  
 PFAFF 1183;1183- D

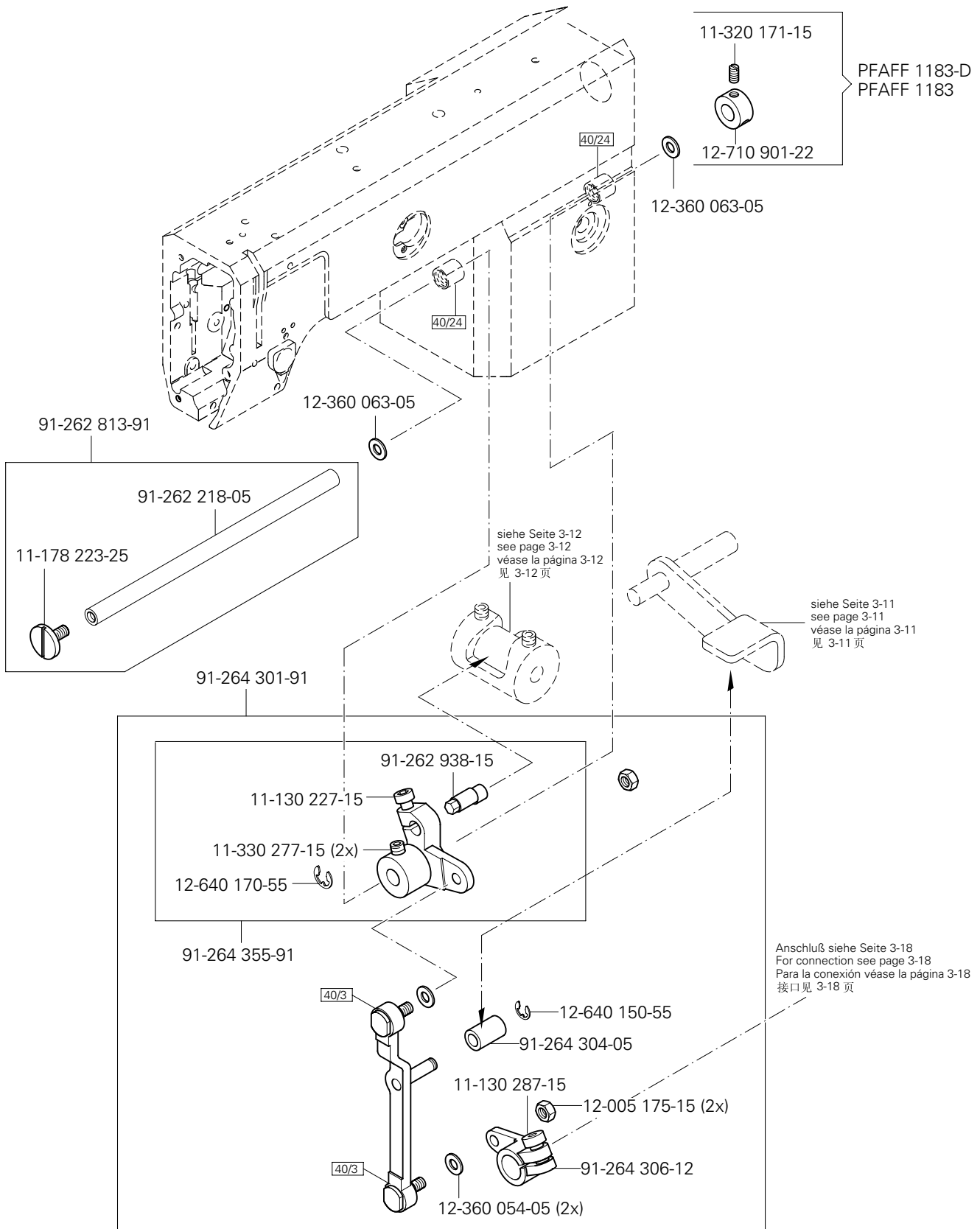
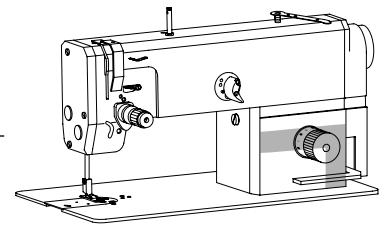

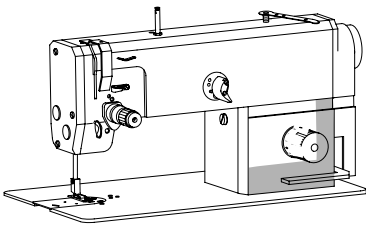

Armteile  
 Arm parts  
 Piezas del brazo  
 机臂零件

PFAFF 1181;1181- D  
 PFAFF 1183;1183- D

3.03

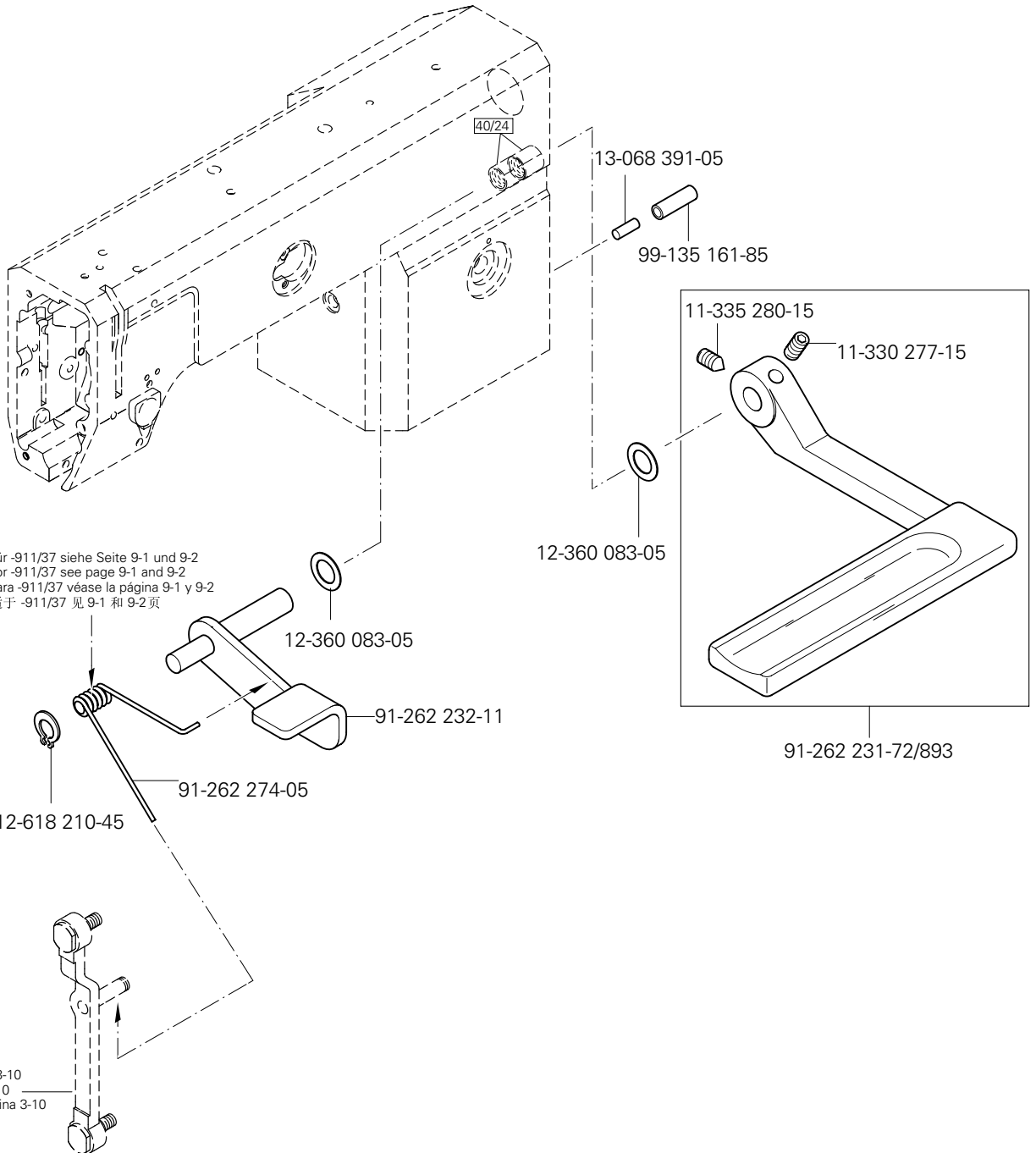

# 3.03

Armteile  
 Arm parts  
 Piezas del brazo  
 机臂零件

PFAFF 1181;1181- D  
 PFAFF 1183;1183- D

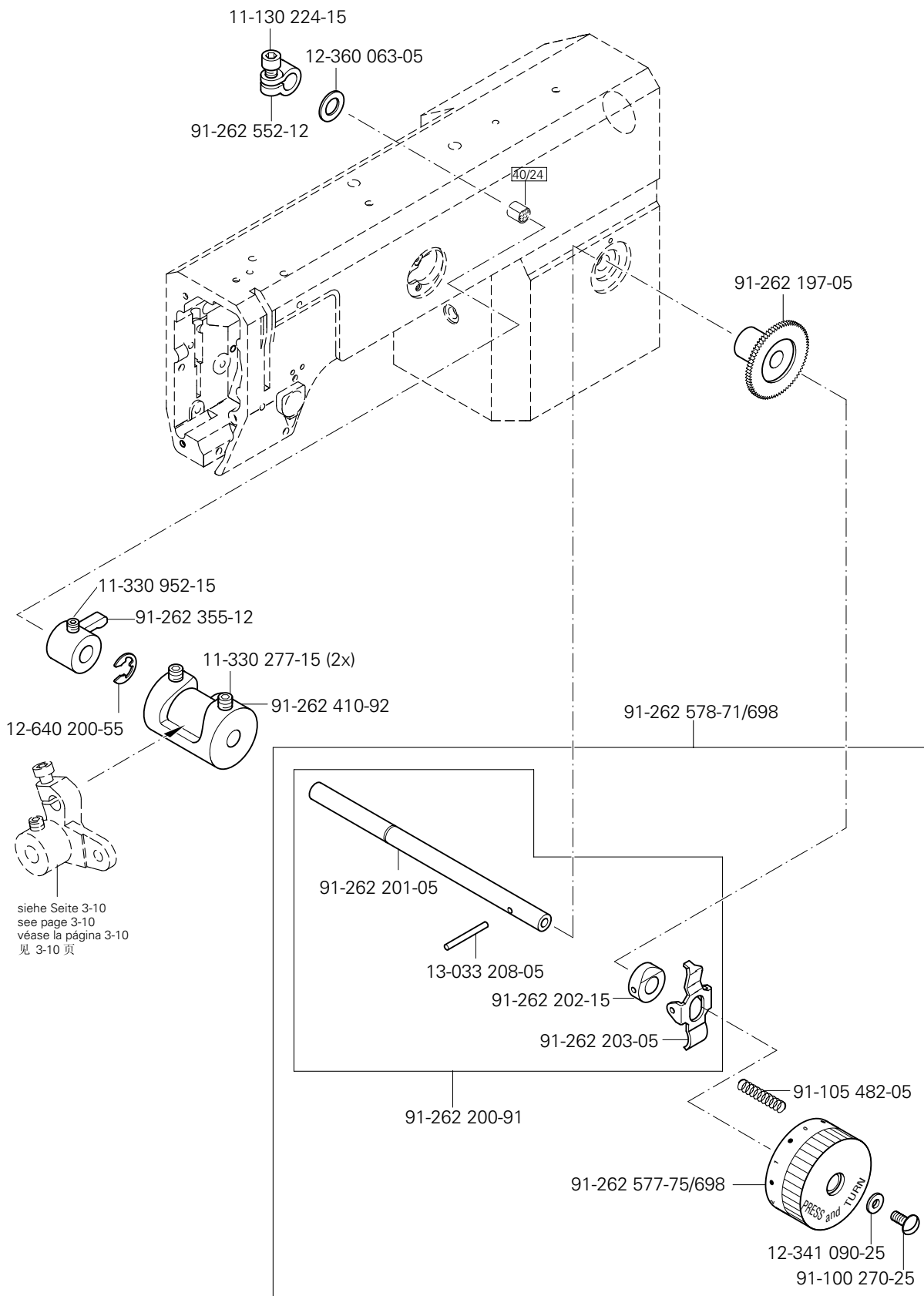
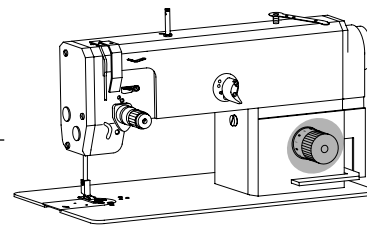

siehe Seite 3-10  
 see page 3-10  
 véase la página 3-10  
 见 3-10 页

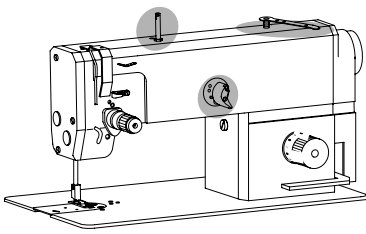

Armteile  
 Arm parts  
 Piezas del brazo  
 机臂零件

PFAFF 1181;1181- D  
 PFAFF 1183;1183- D

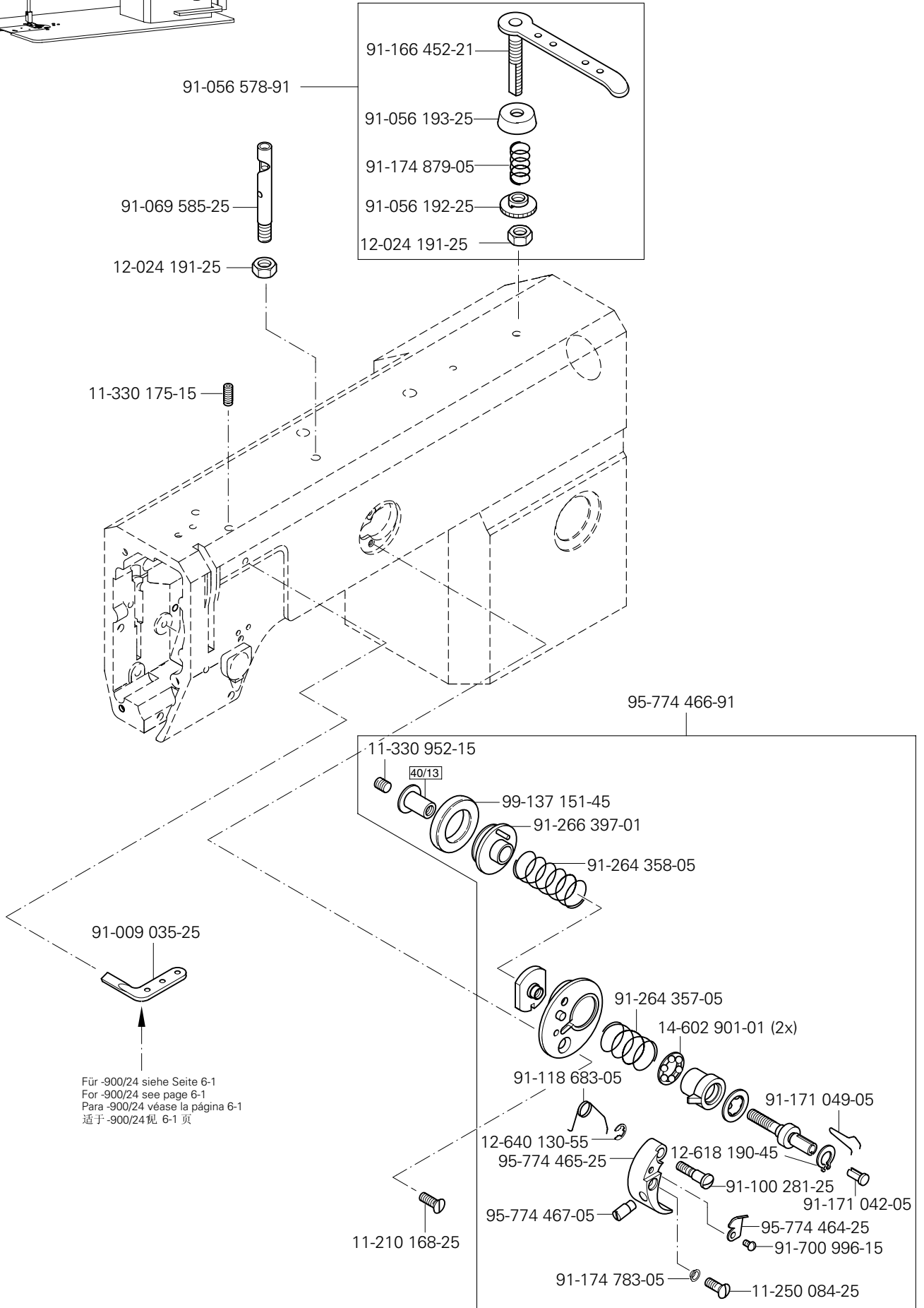

# 3.04

Grundplattenteile  
Bedplate parts  
Piezas del cárter  
底板零件

PFAFF 1181;1181- D  
PFAFF 1183;1183- D

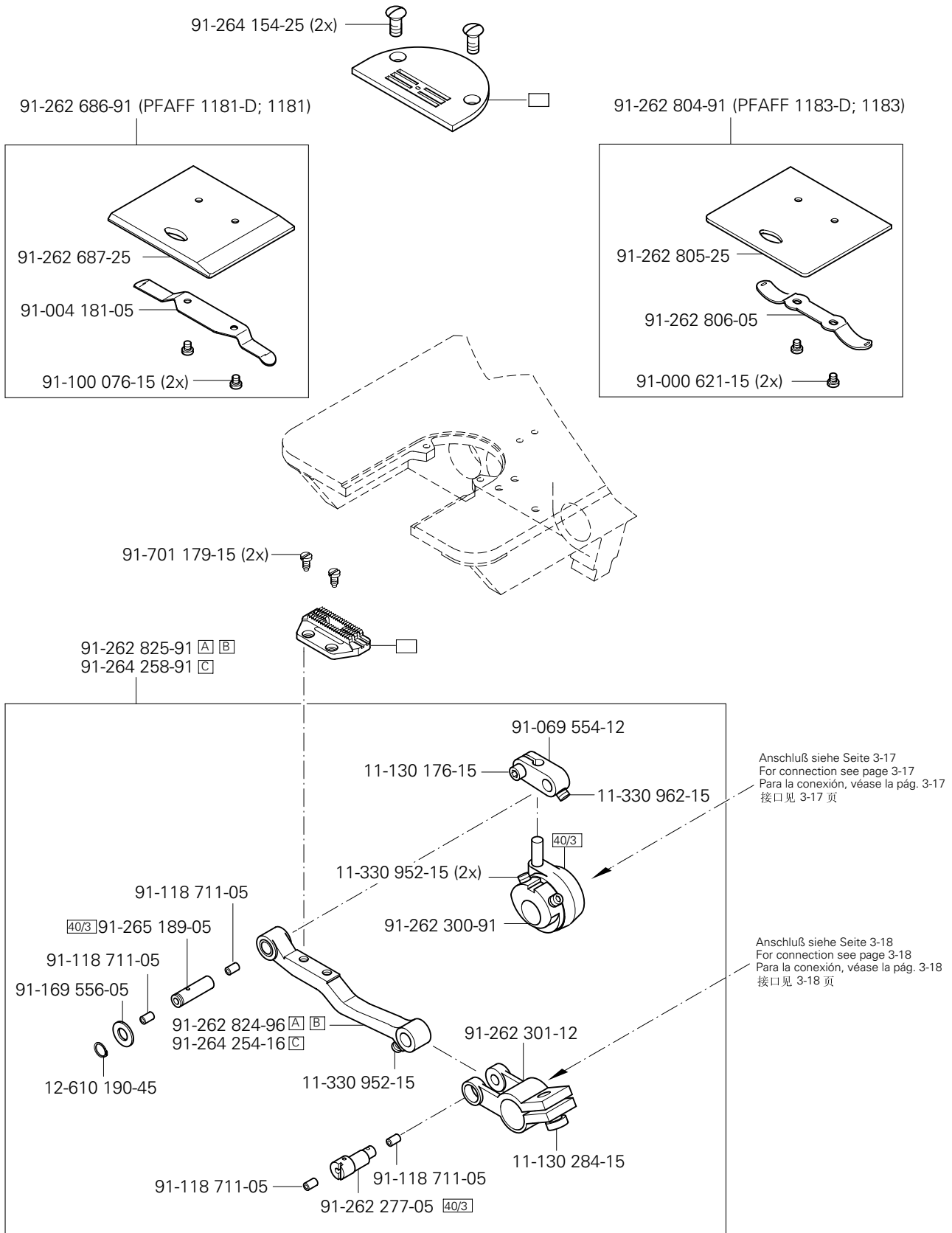
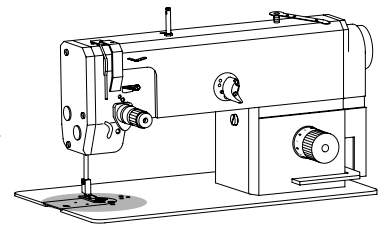



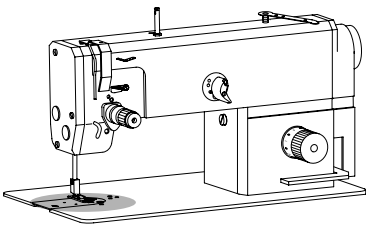

Grundplattenteile  
Bedplate parts  
Piezas del cárter  
底板零件

PFAFF 1181- D  
PFAFF 1183- D

3.04

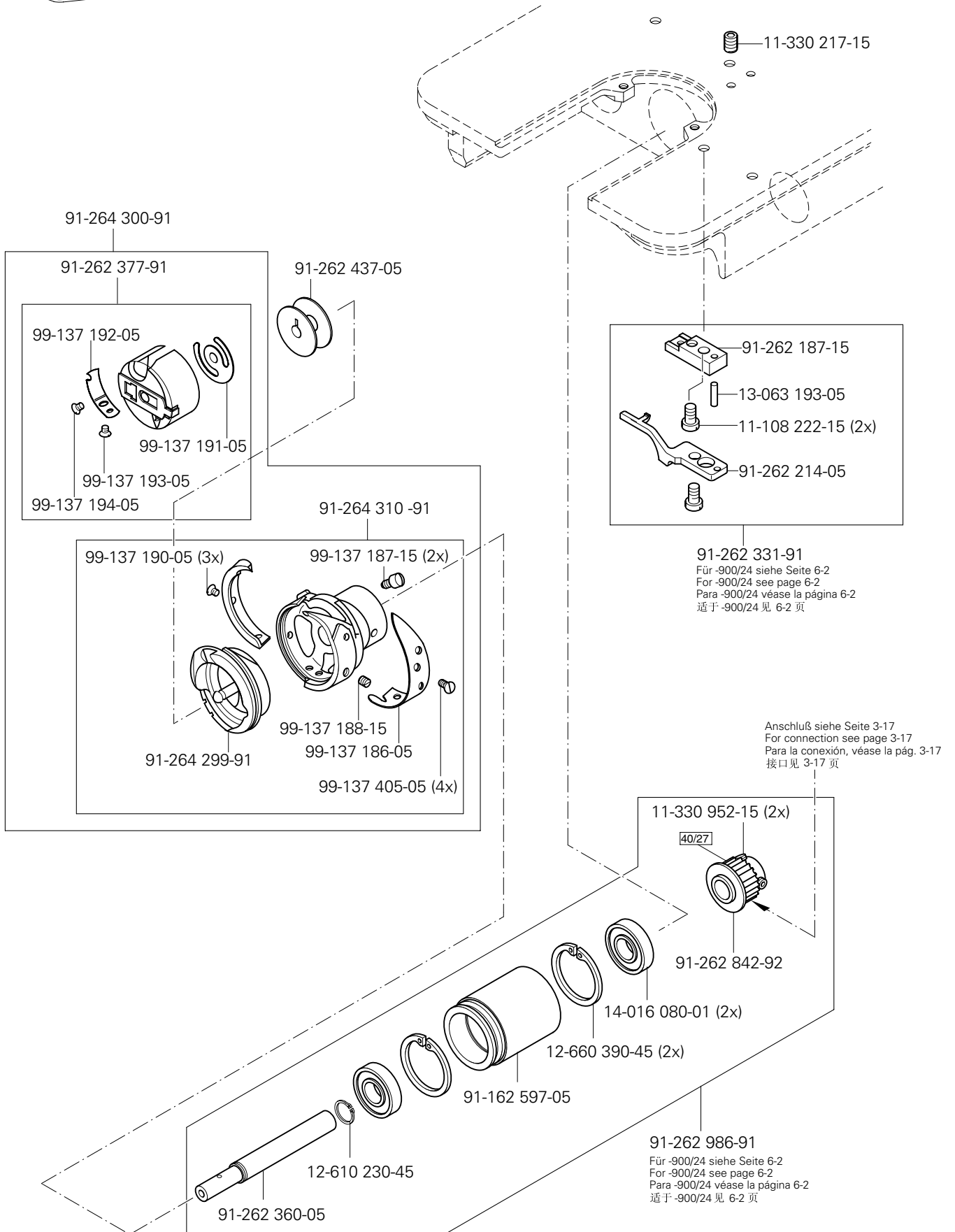

# 3.04

Grundplattenteile  
Bedplate parts  
Piezas del cárter  
底板零件

PFAFF 1181  
PFAFF 1183

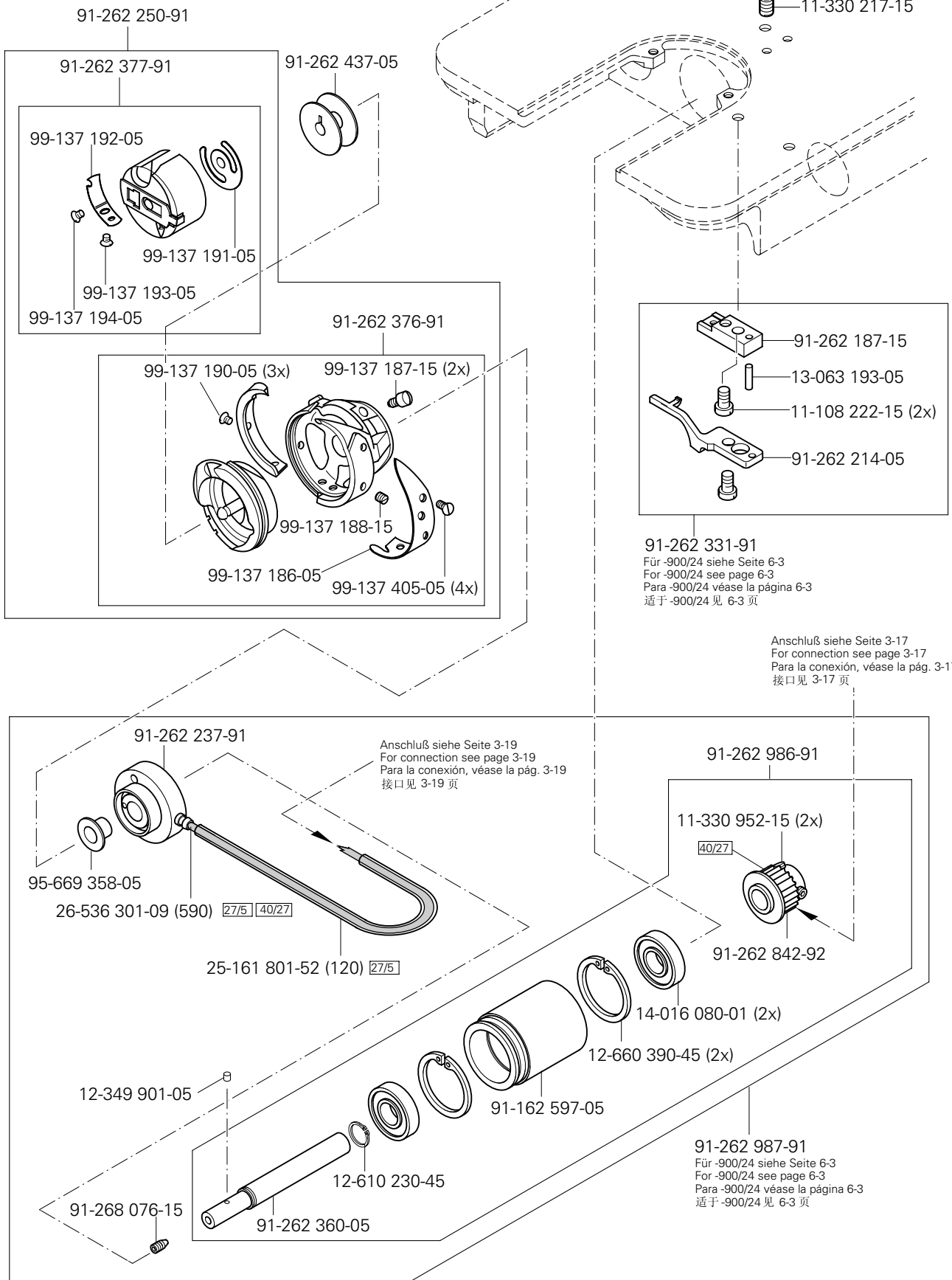
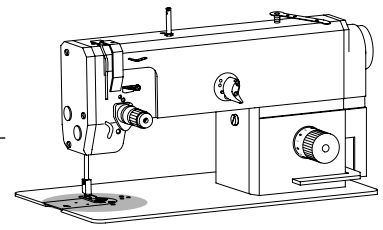

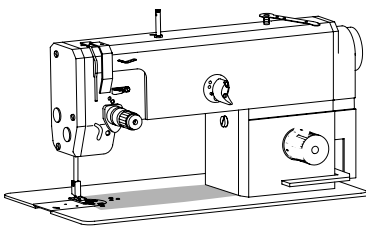

Grundplattenteile  
Bedplate parts  
Piezas del cárter  
底板零件

PFAFF 1181;1181- D  
PFAFF 1183;1183- D

3.04

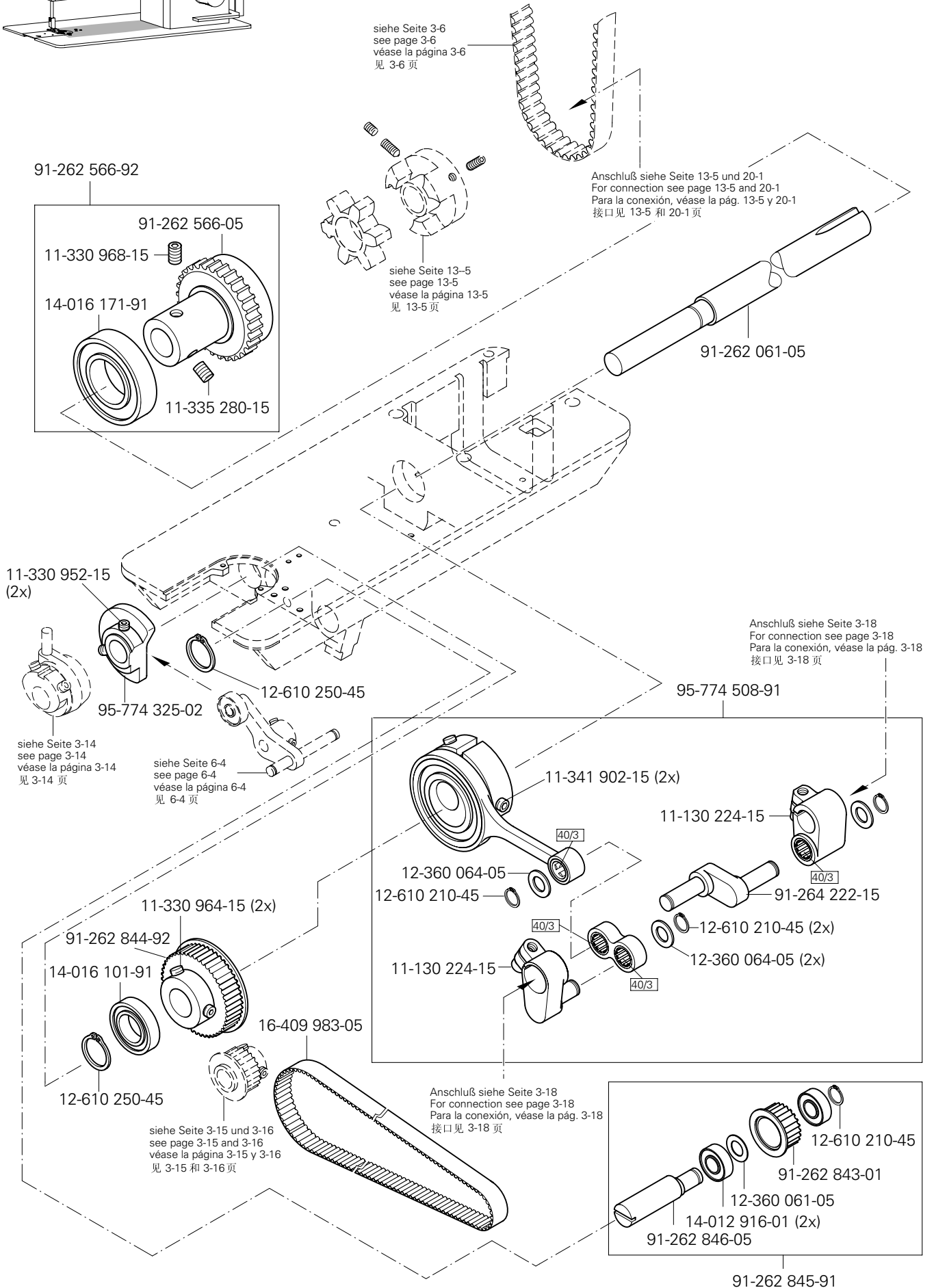

# 3.04

Grundplattenteile  
Bedplate parts  
Piezas del cárter  
底板零件

PFAFF 1181;1181- D  
PFAFF 1183;1183- D

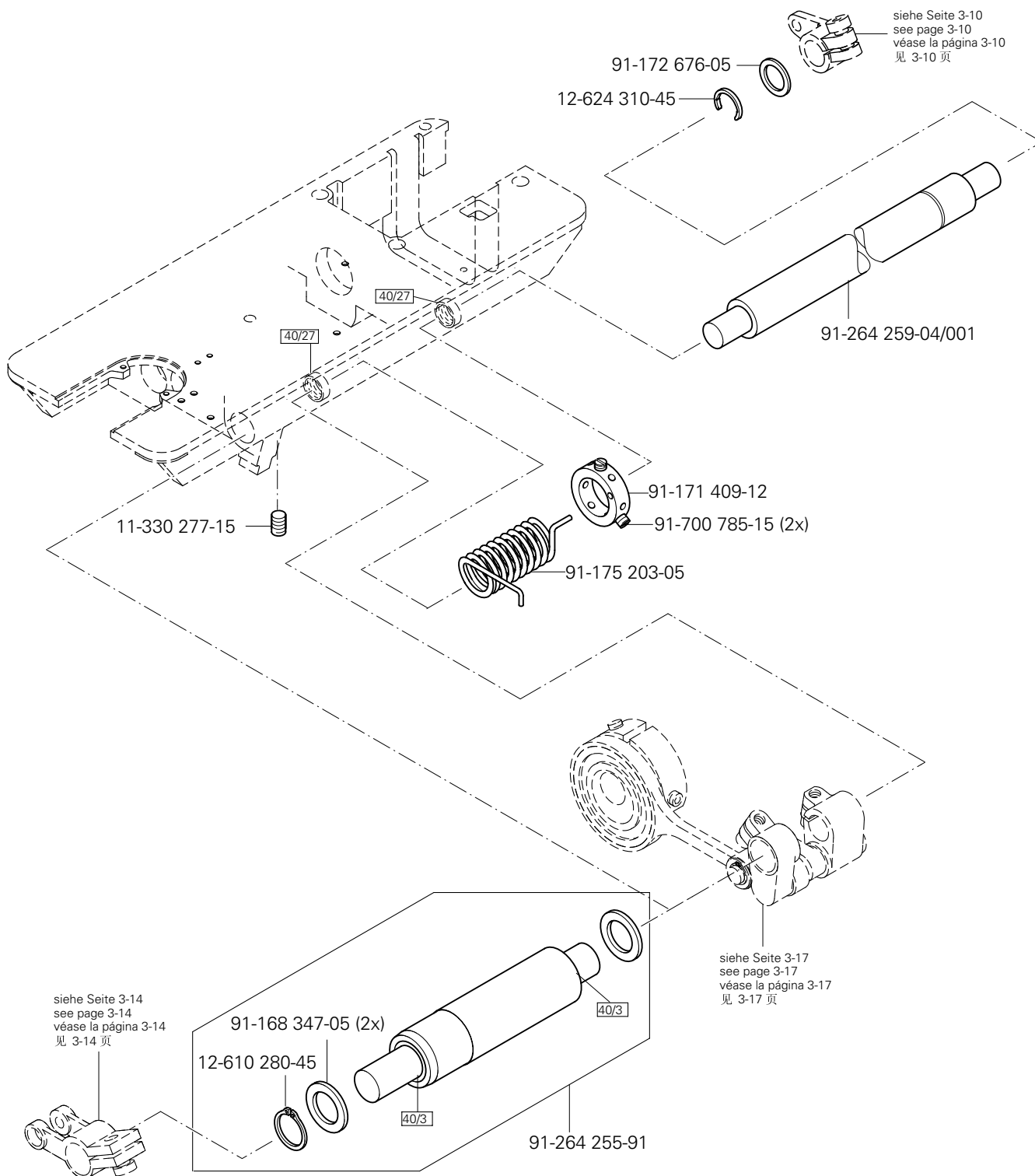
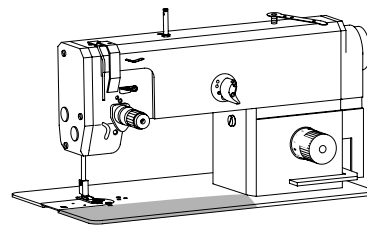

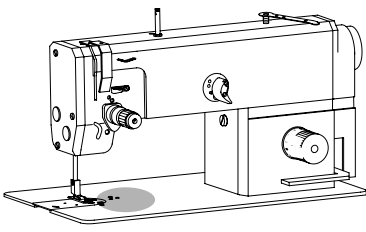

Grundplattenteile  
 Bedplate parts  
 Piezas del cárter  
 底板零件

PFAFF 1181  
 PFAFF 1183

3.04

siehe Seite 3-4 und 3-5  
 see page 3-4 and 3-5  
 véase la página 3-4 y 3-5  
 见 3-4 和 3-5 页

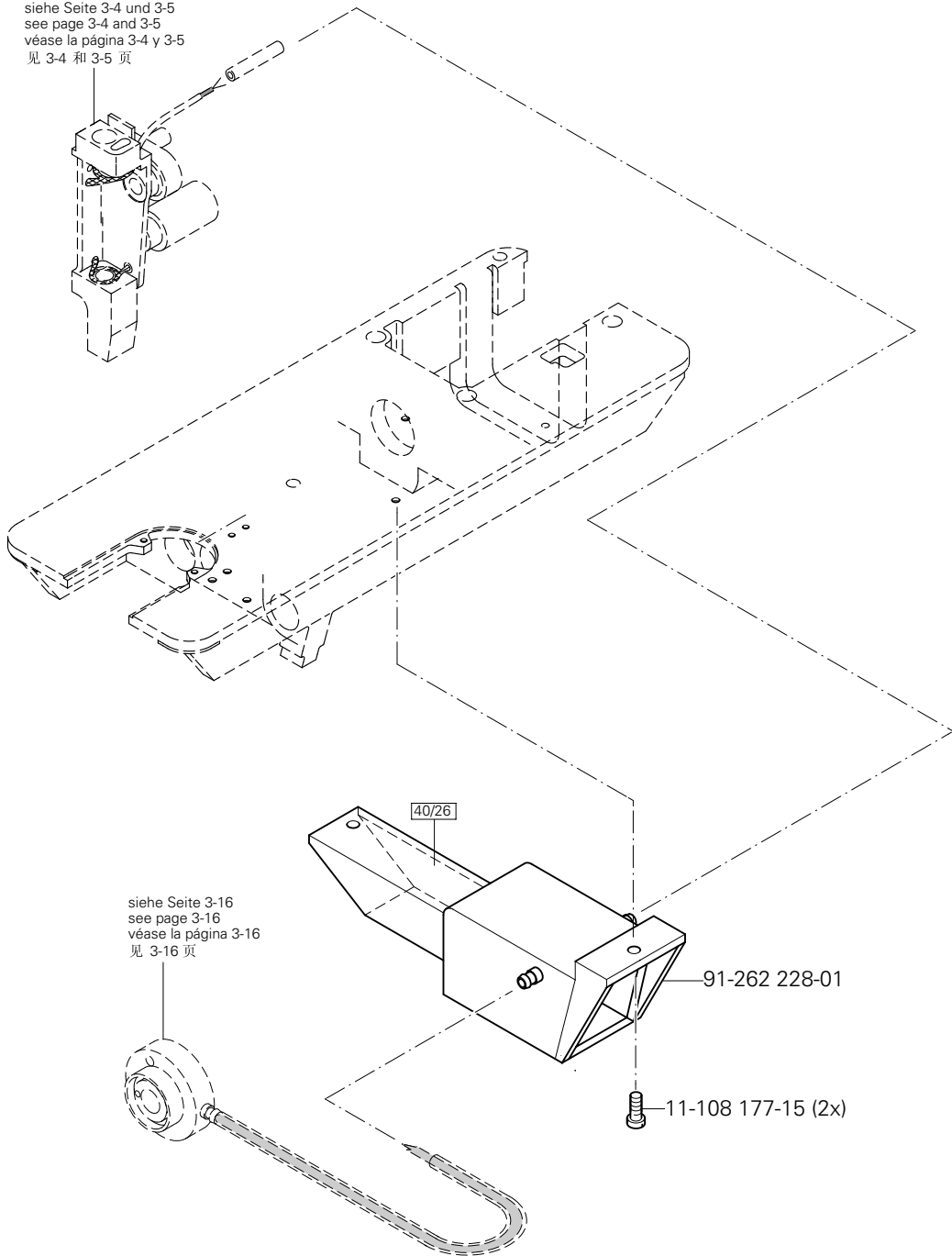

siehe Seite 3-16  
 see page 3-16  
 véase la página 3-16  
 见 3-16 页

# 3.04

Grundplattenteile  
Bedplate parts  
Piezas del cárter  
底板零件

PFAFF 1181;1181- D  
PFAFF 1183;1183- D

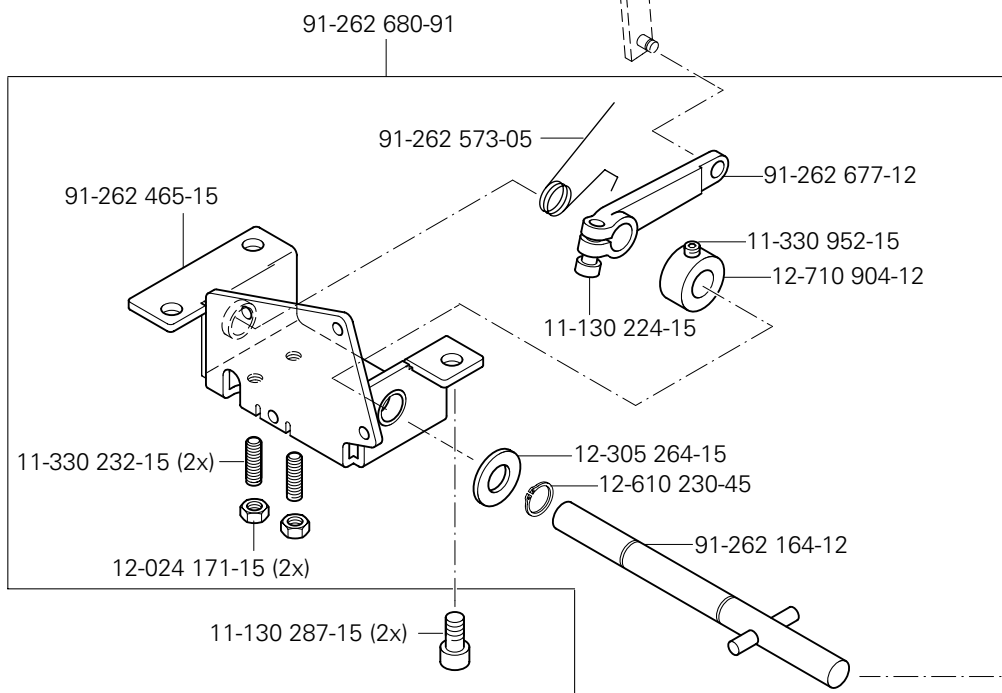
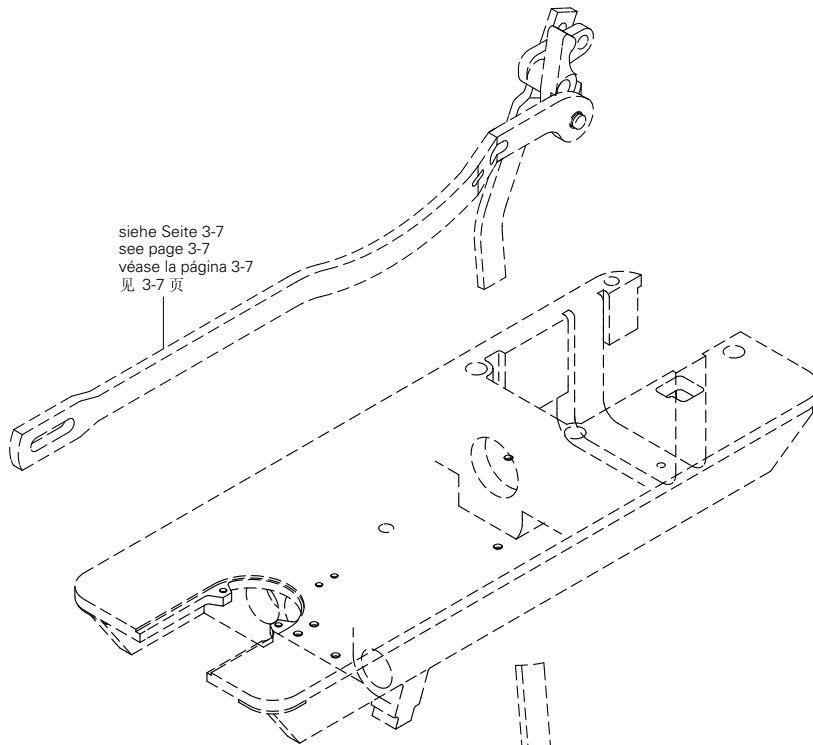
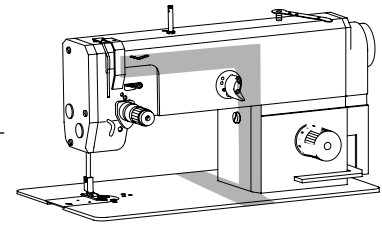

Anschluß siehe Seite 18-1  
For connection see page 18-1  
Para la conexión, véase la pág. 18-1  
接口见 18-1 页

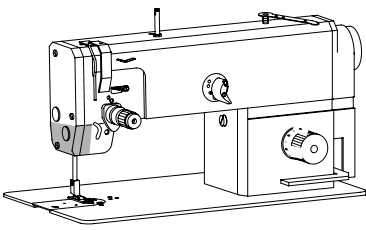

SRP  
SRP  
SRP  
SRP

PFAFF 1181;1181- D  
PFAFF 1183;1183- D

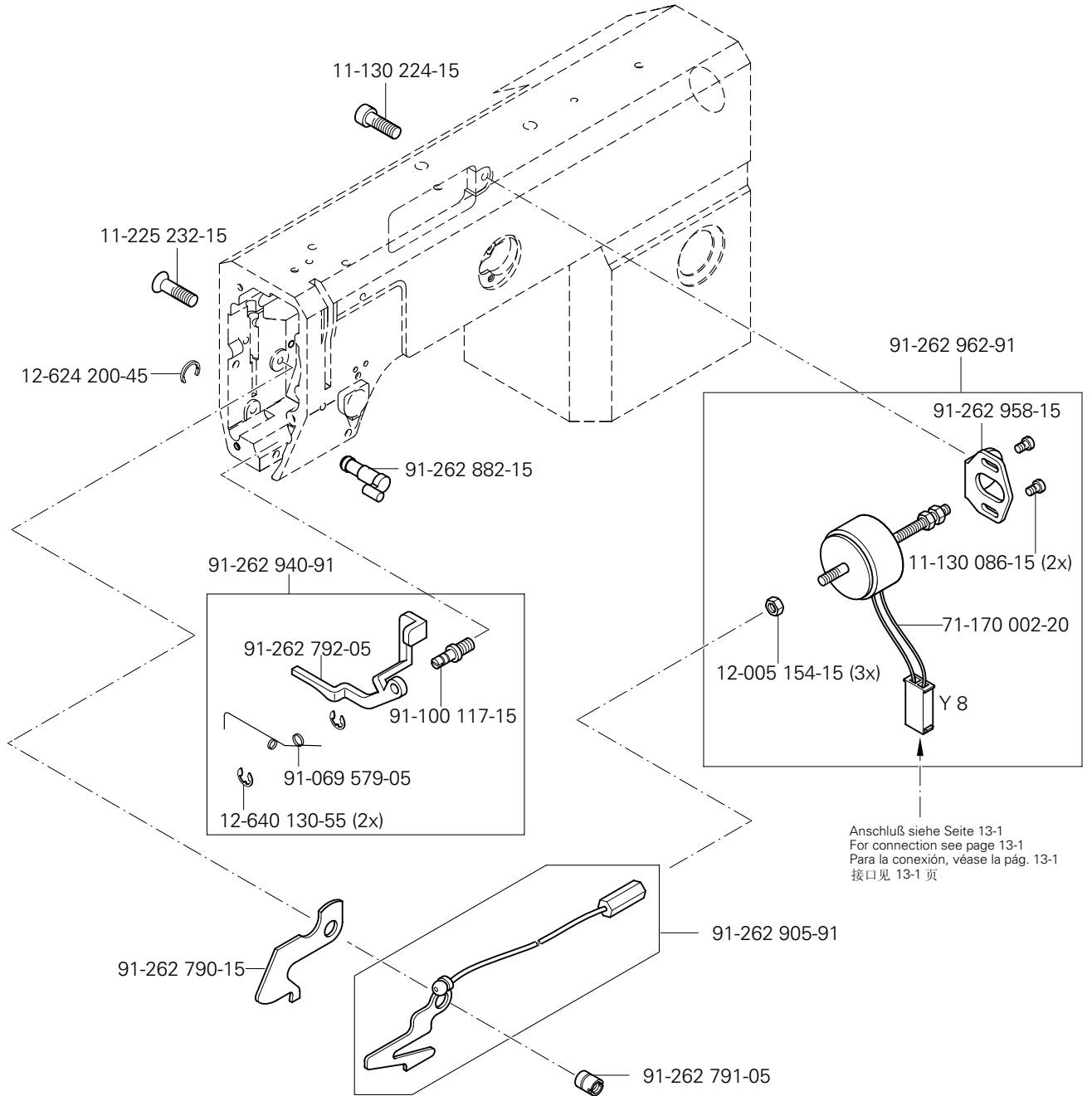

# 4

SRP  
 SRP  
 SRP PFAFF 1181;1181- D  
 SRP PFAFF 1183;1183- D

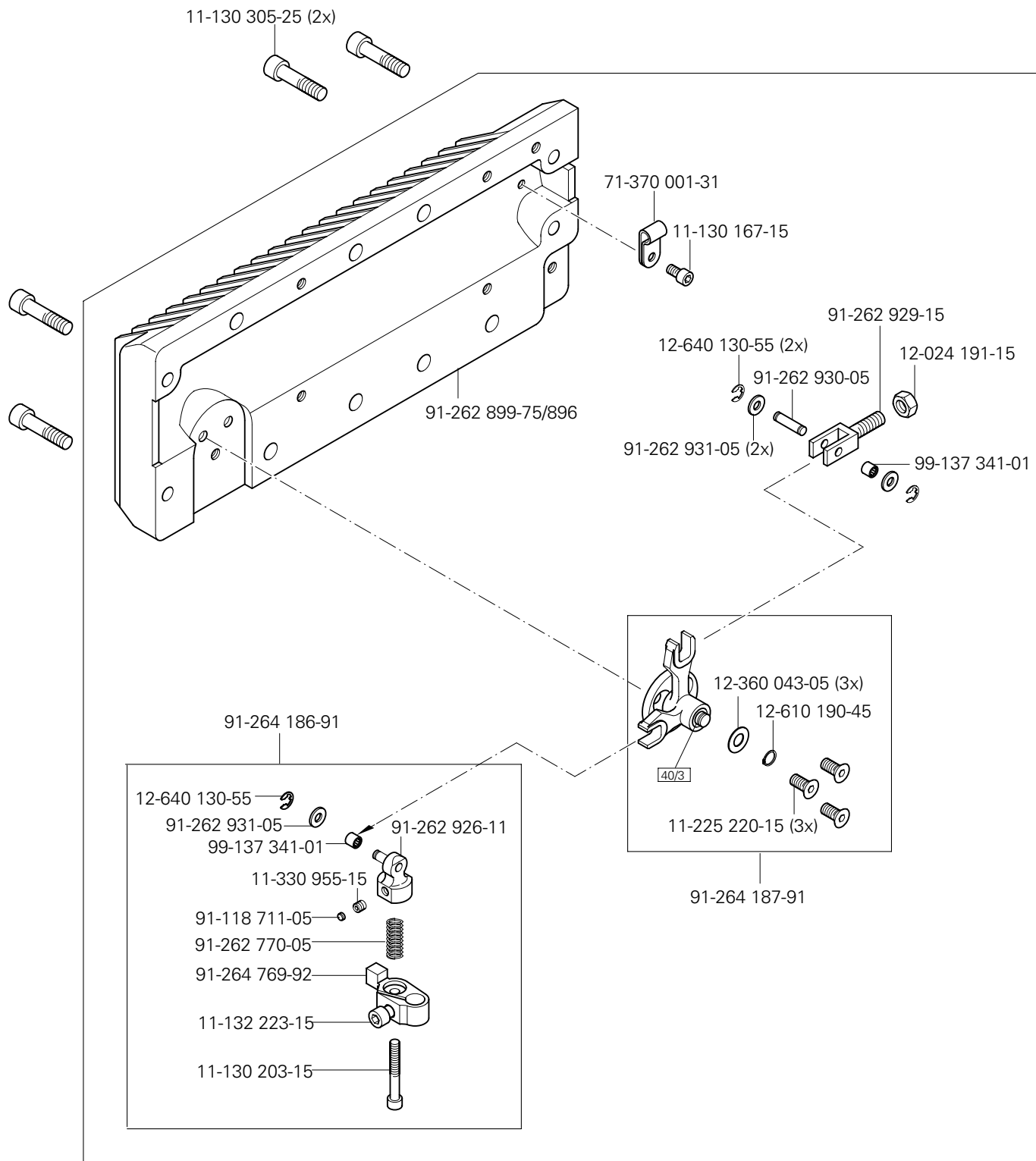
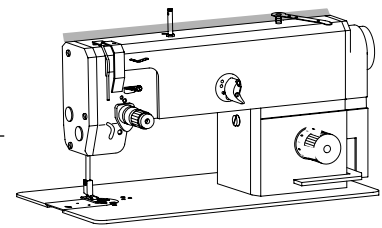



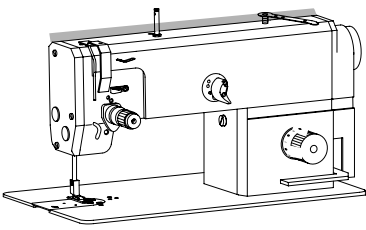

SRP  
SRP  
SRP  
SRP

PFAFF 1181;1181- D  
PFAFF 1183;1183- D

91-264 189-71/896

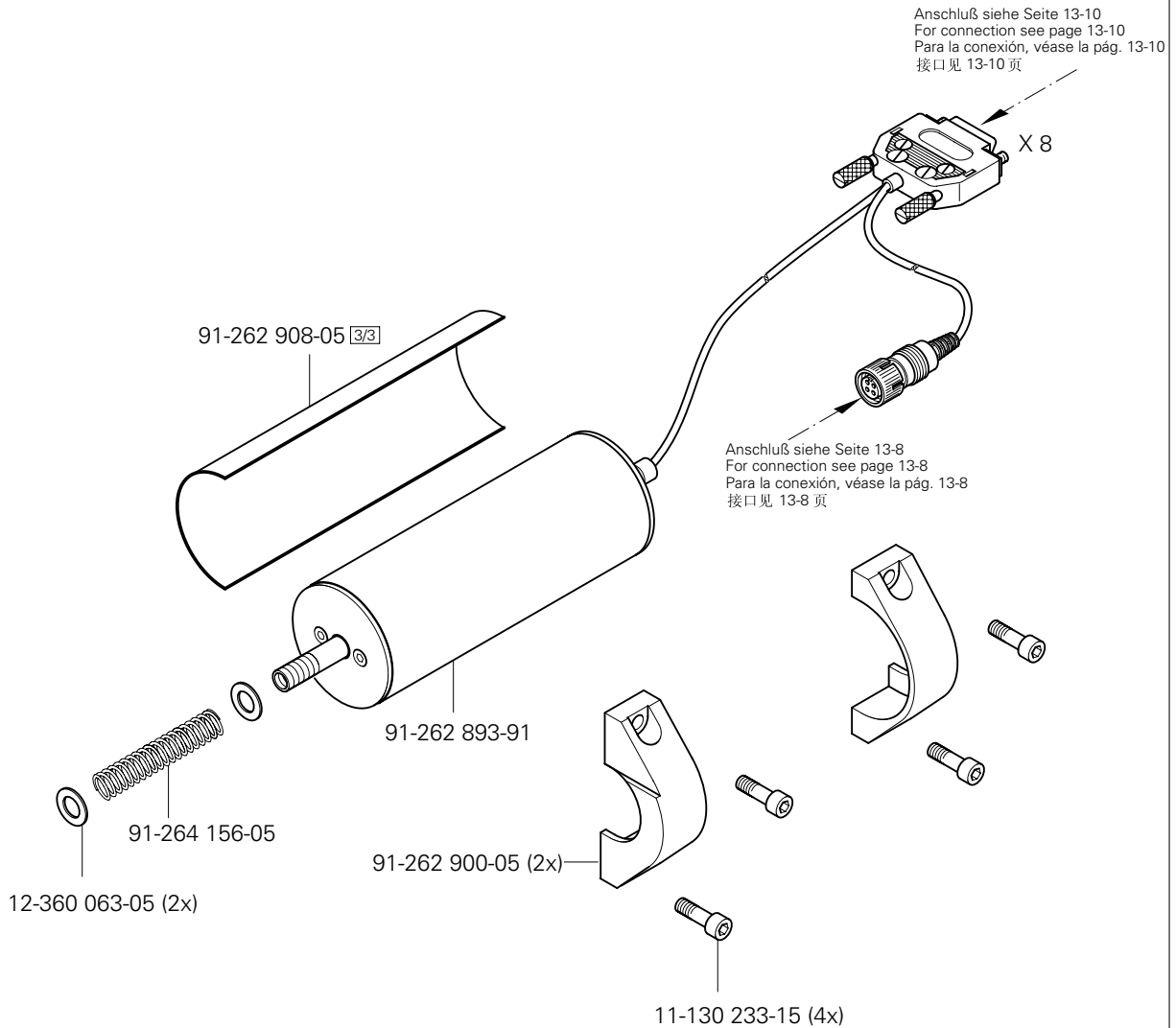

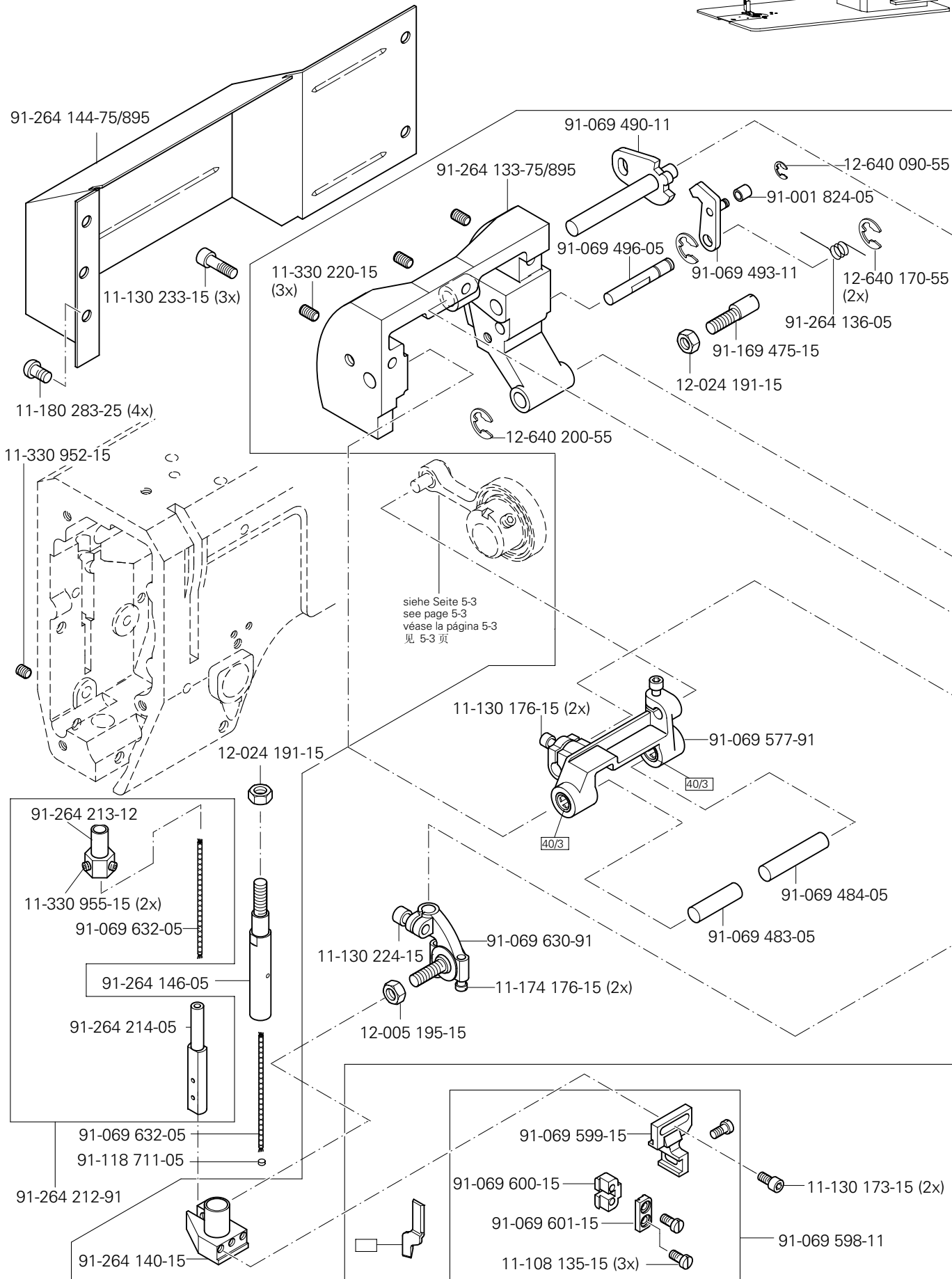
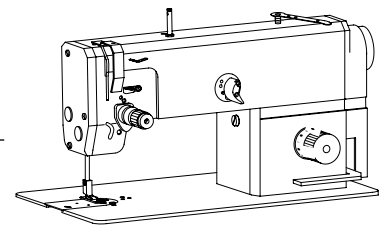

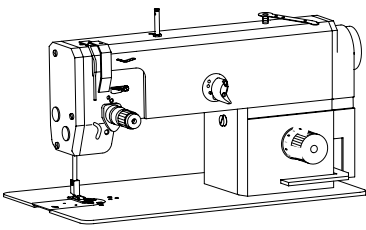

Kanten-Beschneideinrichtung (-731/01)  
 Edge trimmer (-731/01)  
 Recortador (-731/01)  
 切边器 (-731/01)

PFAFF 1181;1181- D  
 PFAFF 1183;1183- D

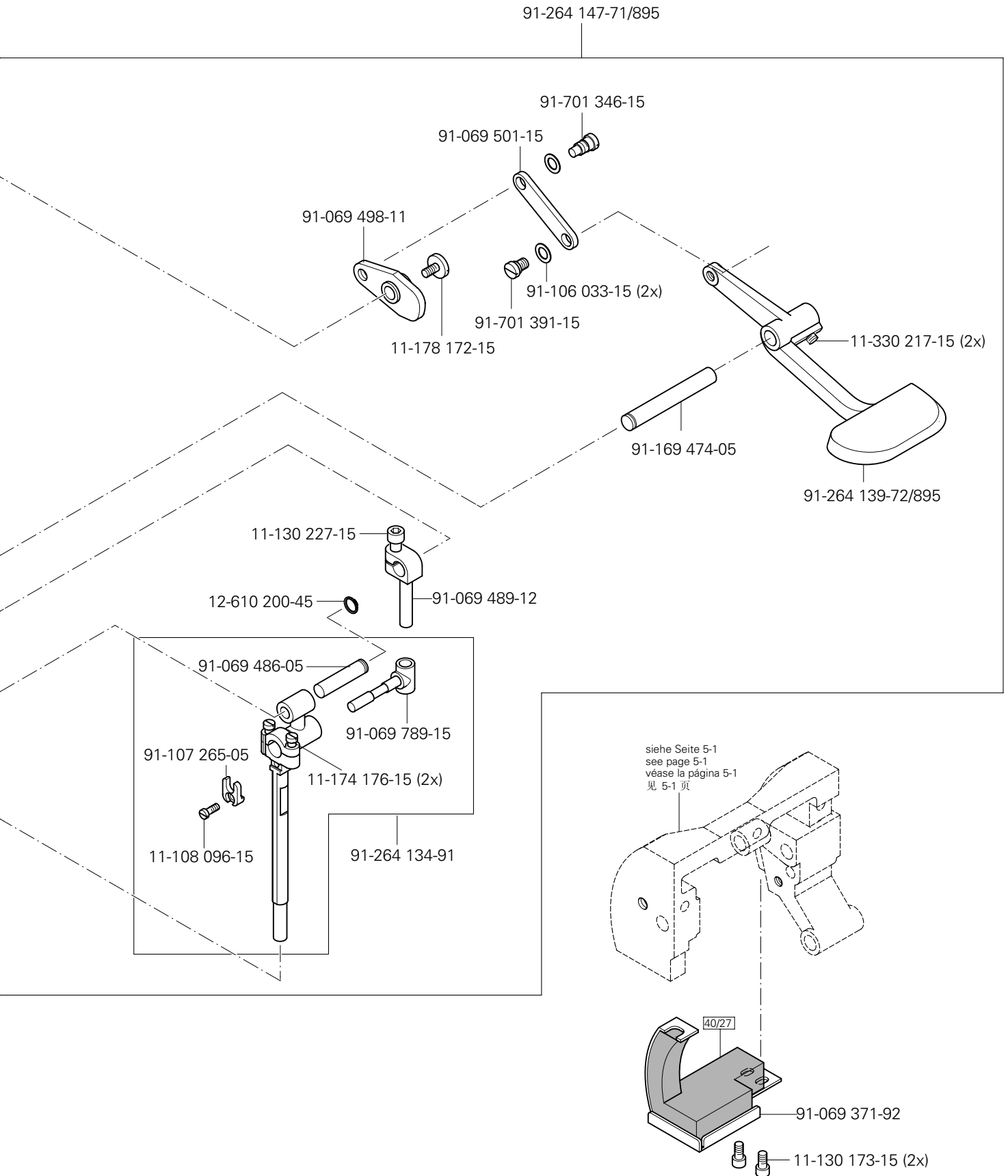

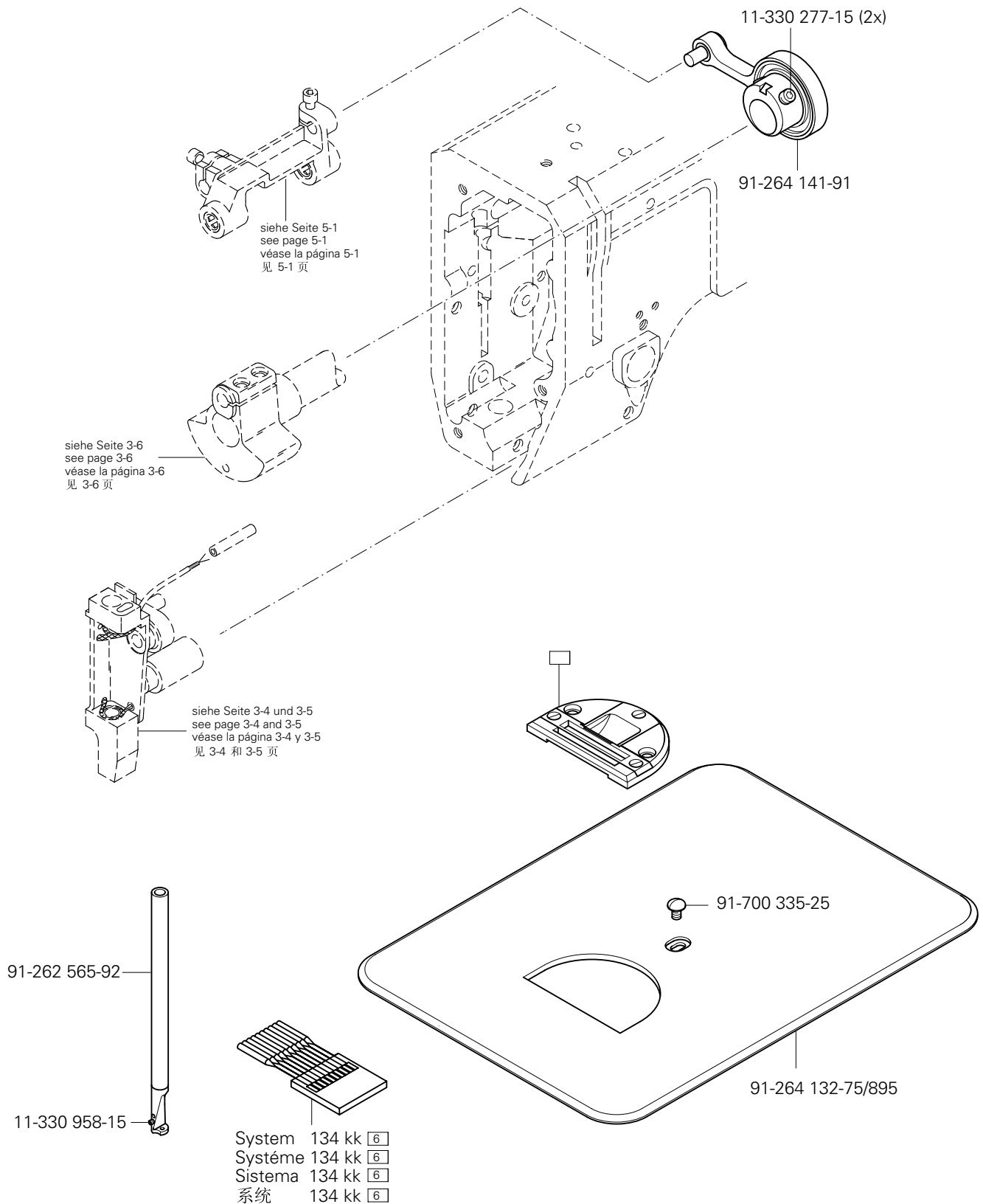
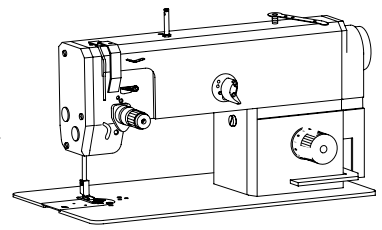

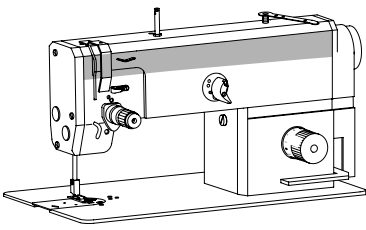

Fadenabschneid-Einrichtung (-900/24)  
 Thread trimmer (-900/24)  
 Cortahilos (-900/24)  
 切线器 (-900/24)

PFAFF 1181;1181- D  
 PFAFF 1183;1183- D

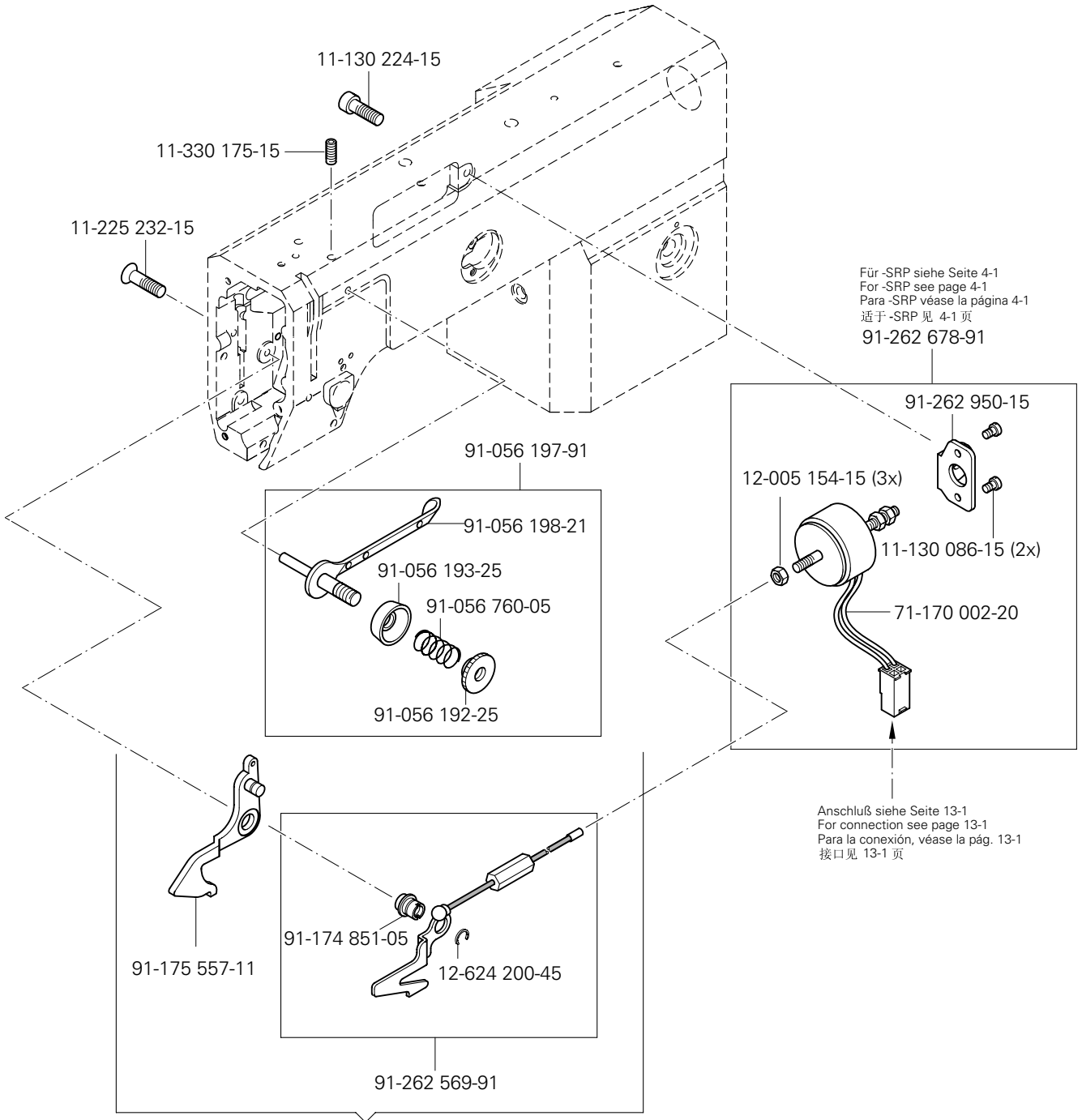

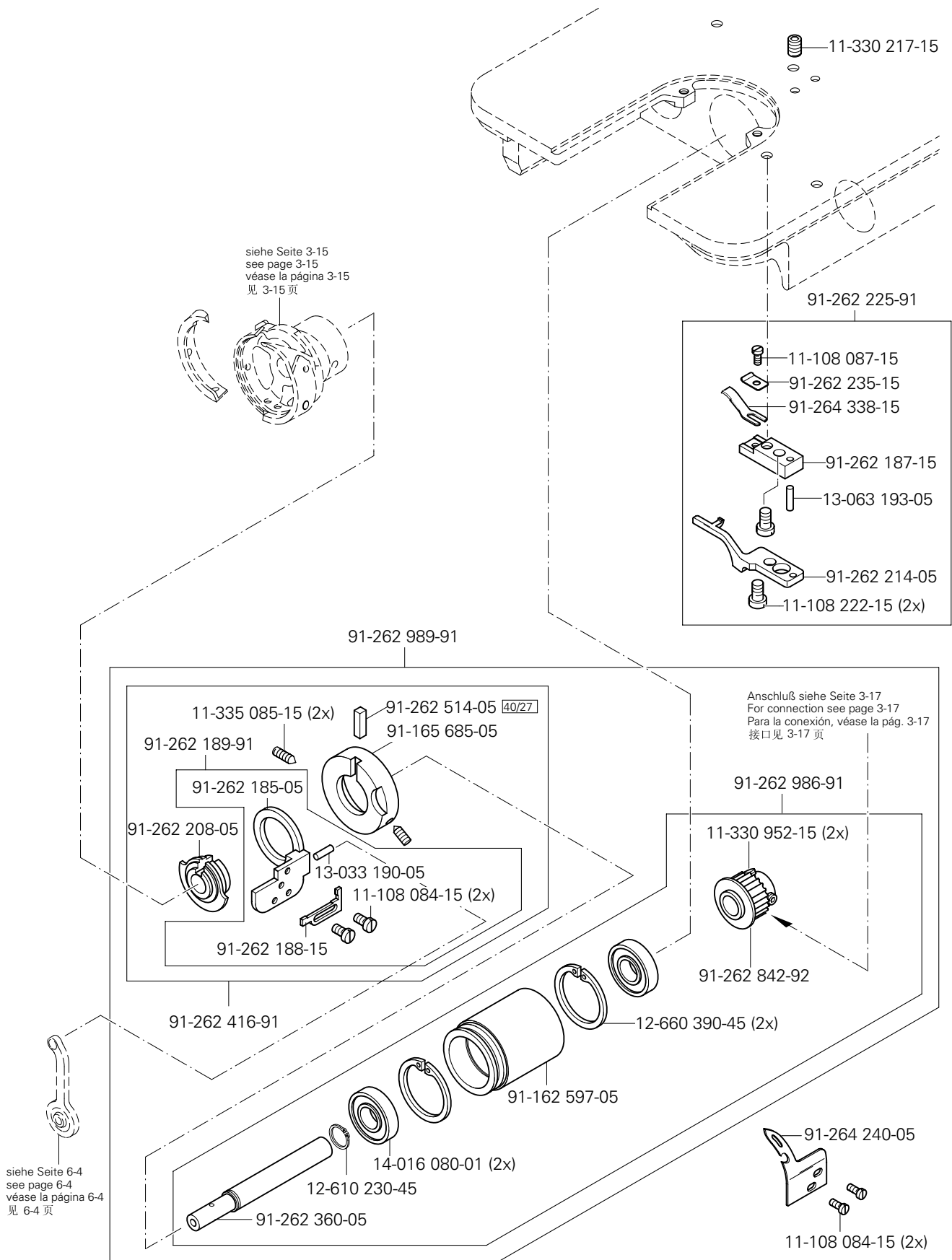
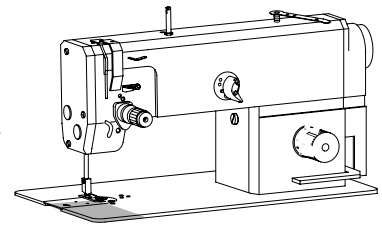

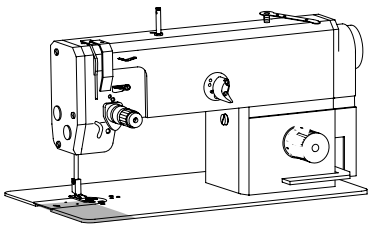

Fadenabschneid-Einrichtung (-900/24)  
 Thread trimmer (-900/24)  
 Cortahilos (-900/24)  
 切线器 (-900/24)

PFAFF 1181  
 PFAFF 1183

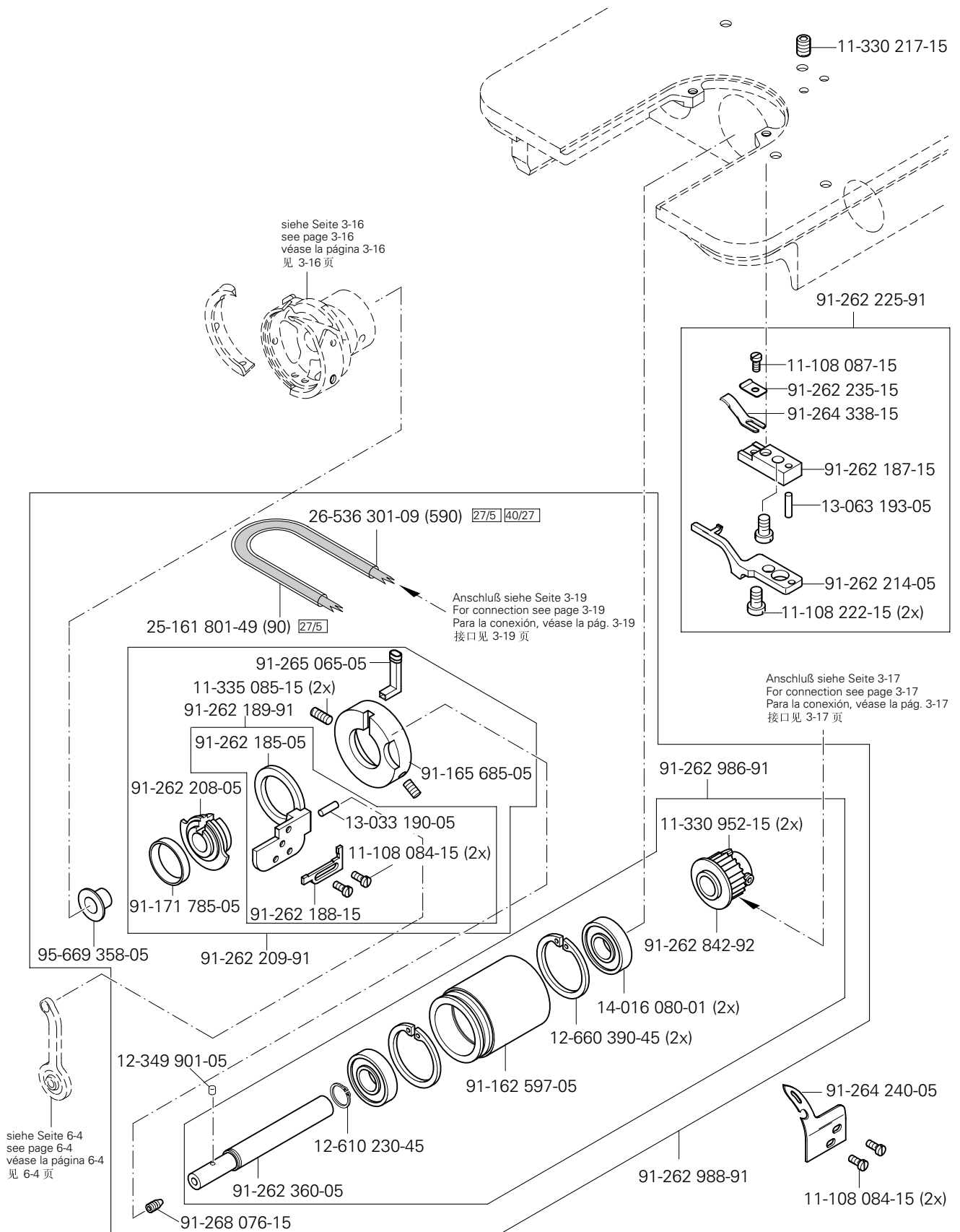

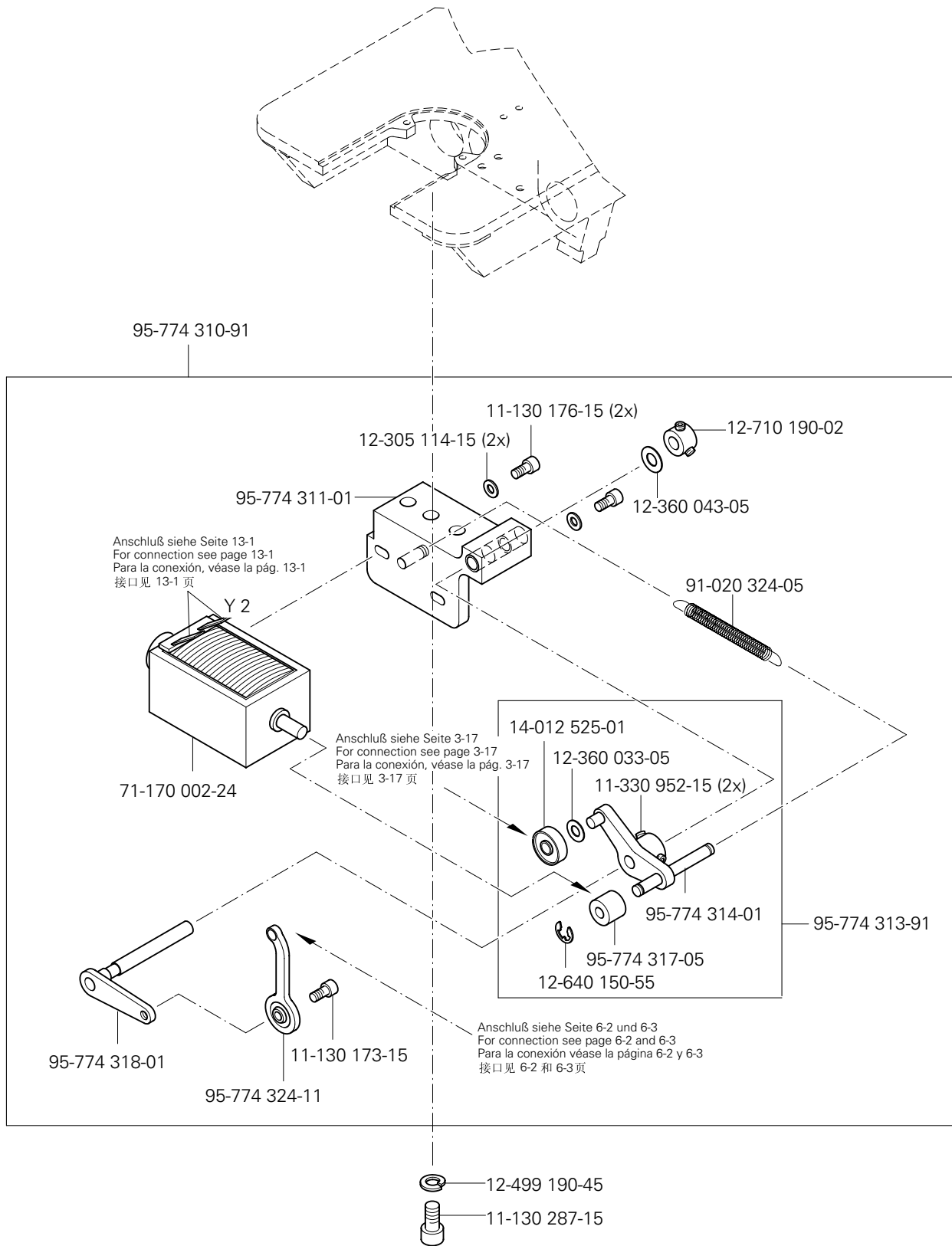
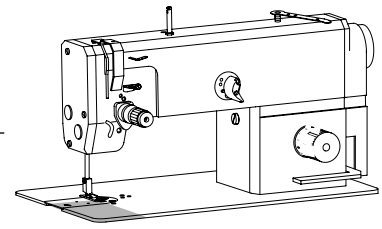



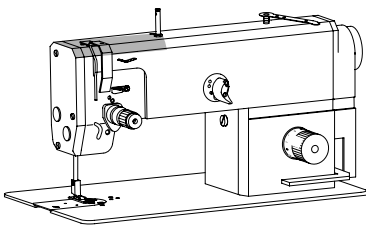

Fadenabstreif-Einrichtung (-909/04)  
 Thread wiper (-909/04)  
 Retirahilos (-909/04)  
 拨线器 (-909/04)

PFAFF 1181-900/24; 1181- D-900/24  
 PFAFF 1183-900/24; 1183- D-900/24

91-262 440-71/895

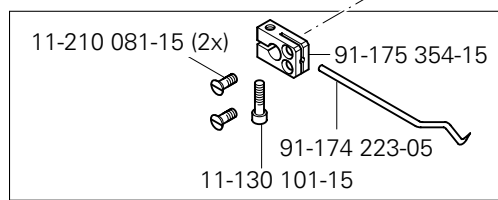
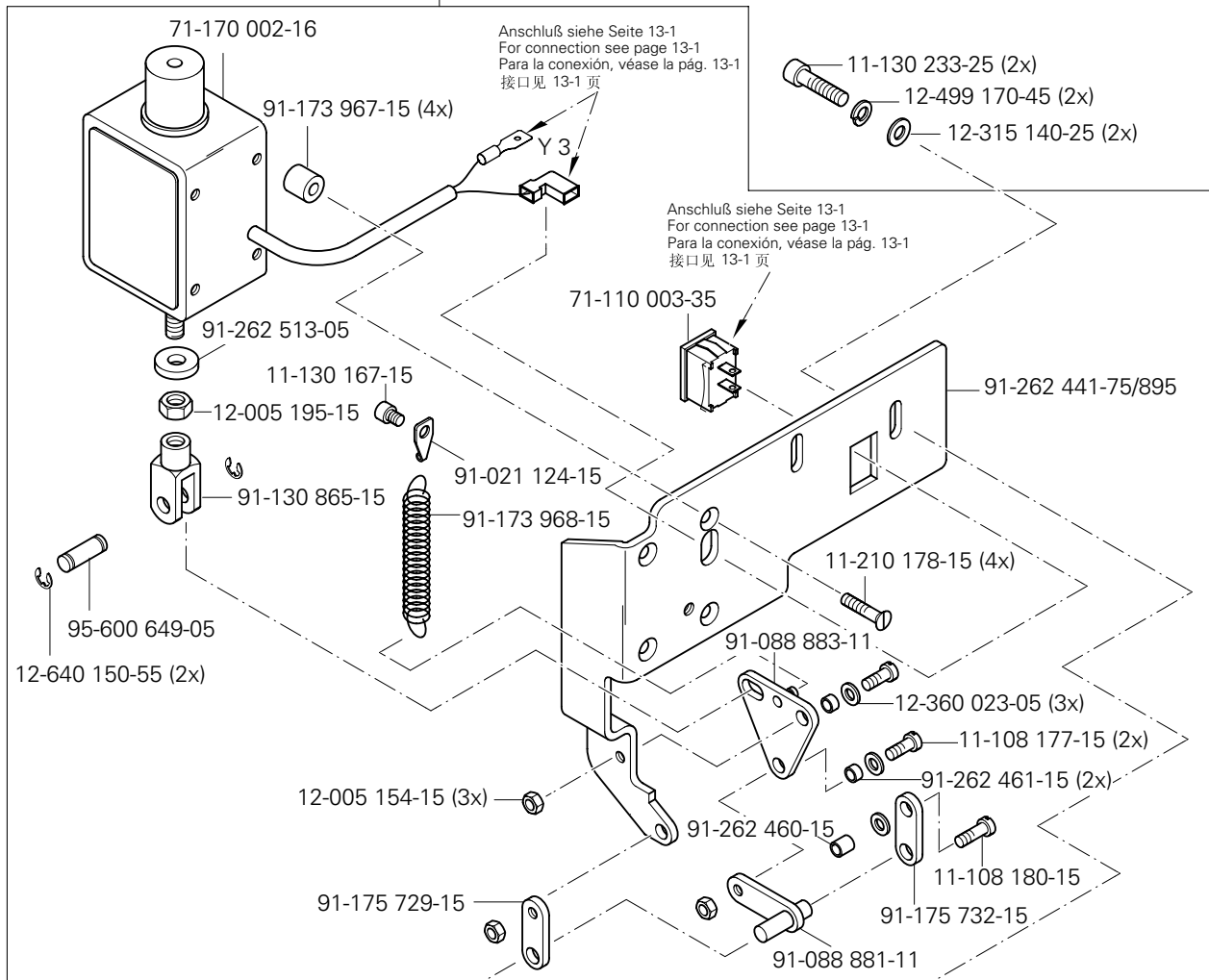

91-175 806-91

11-108 285-15 (5x)

91-262 442-75/895

11-341 904-15

91-175 265-12

siehe Seite 3-2  
 see page 3-2  
 véase la página 3-2  
 见 3-2 页

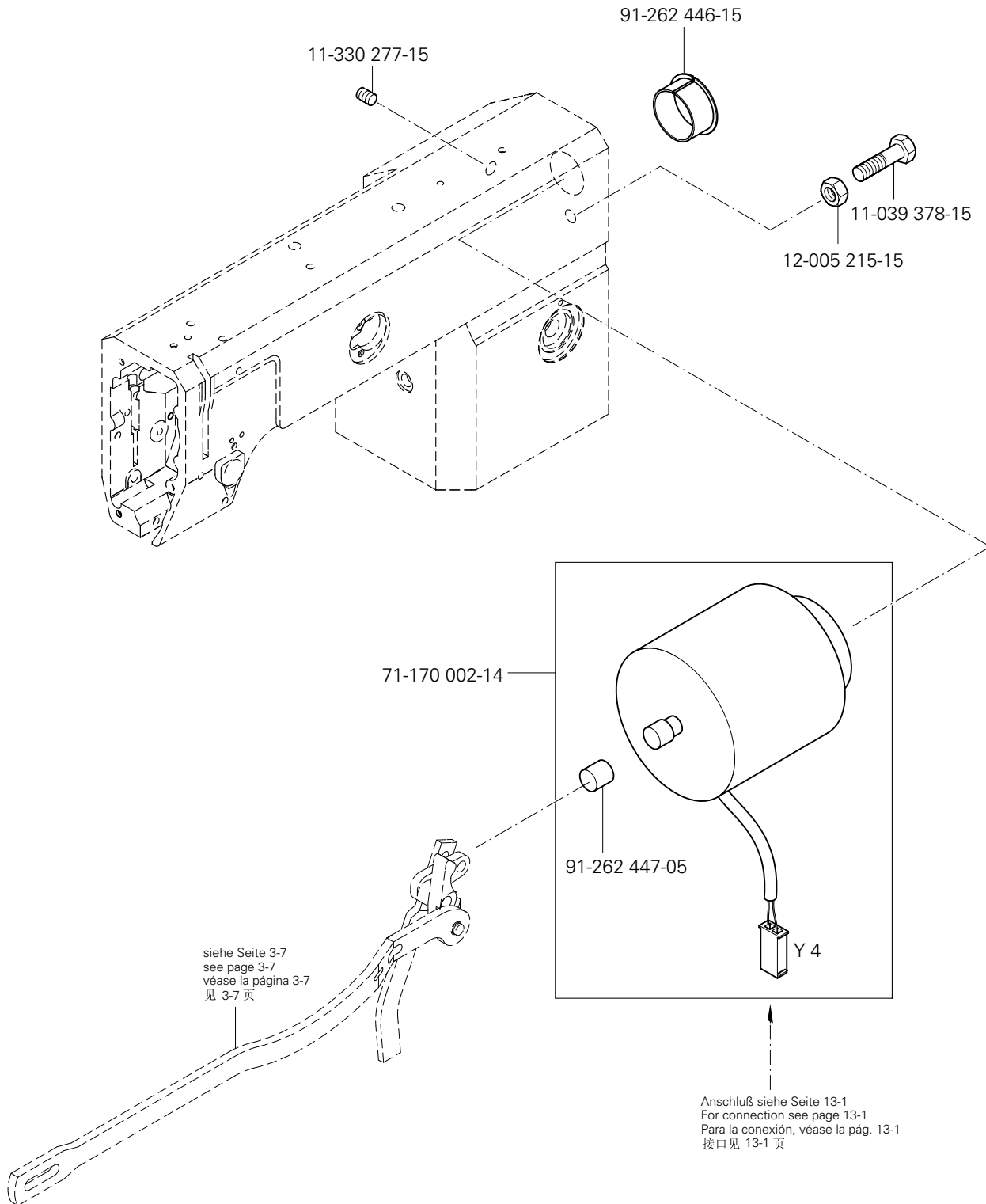
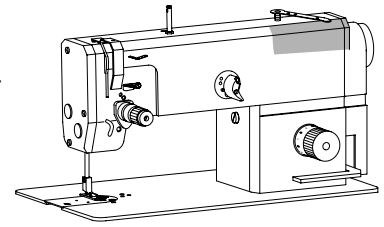

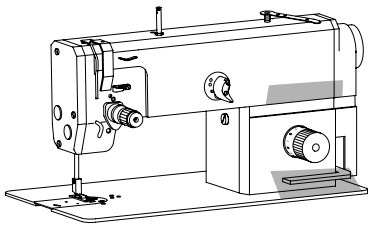

Verriegelungs-Einrichtung (-911/37)  
 Backtacking mechanism (-911/37)  
 Rematador (-911/37)  
 锁紧装置 (-911/37)

PFAFF 1181-900/24; 1181- D-900/24  
 PFAFF 1183-900/24; 1183- D-900/24

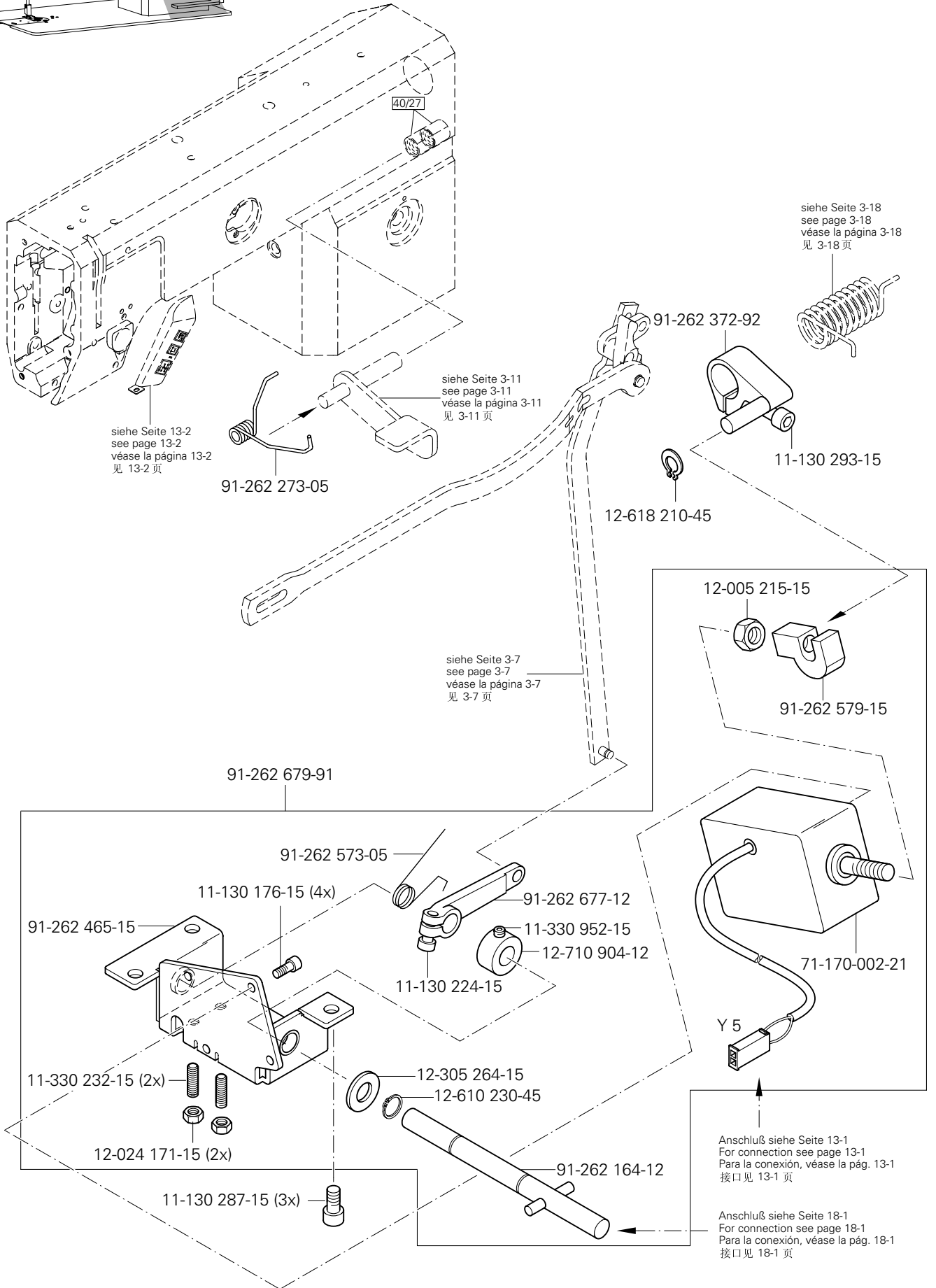

Verriegelungs-Einrichtung (-911/37)

Backtacking mechanism (-911/37)

Rematador (-911/37)

PFAFF 1181 SRP-900/24;1181- D- SRP-900/24

锁紧装置 (-911/37)

PFAFF 1183 SRP-900/24;1183- D- SRP-900/24

9

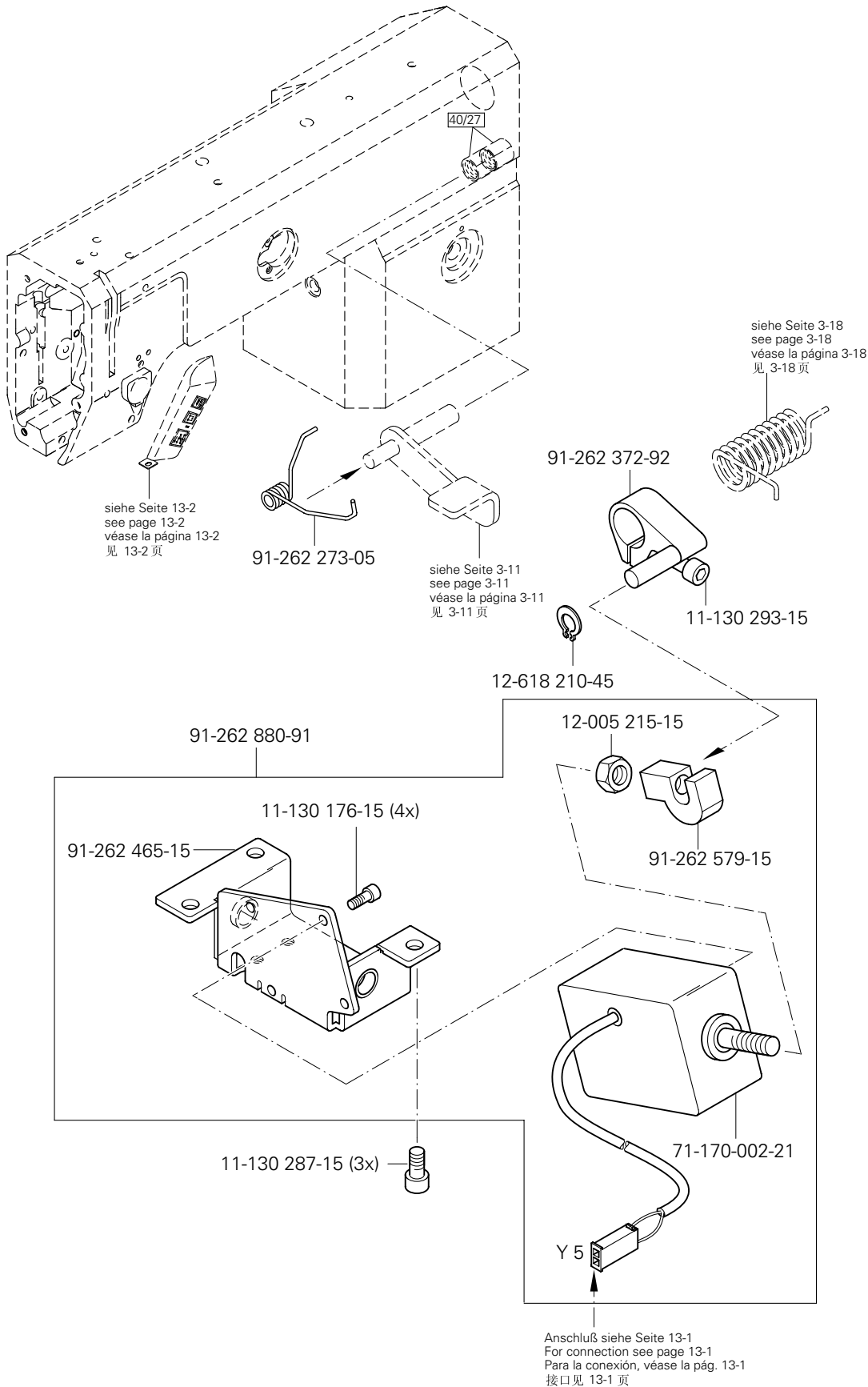
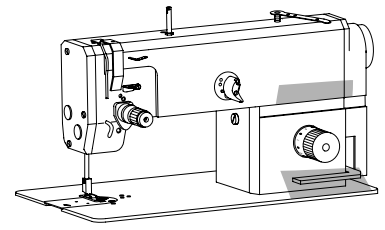

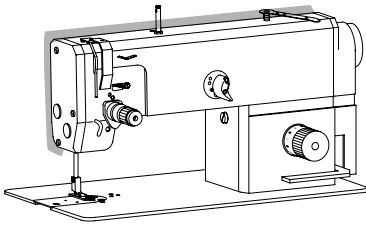

Absaugeinrichtung (-920/06) PFAFF 1181-731/01;1181- D-731/01 Vacuum waste disposal unit (-920/06)  
 Dispositivo de aspiración (-920/06) PFAFF 1183-731/01;1183- D-731/01  
 吹风装置 (-920/06) PFAFF 1183-731/01;1183- D-731/01

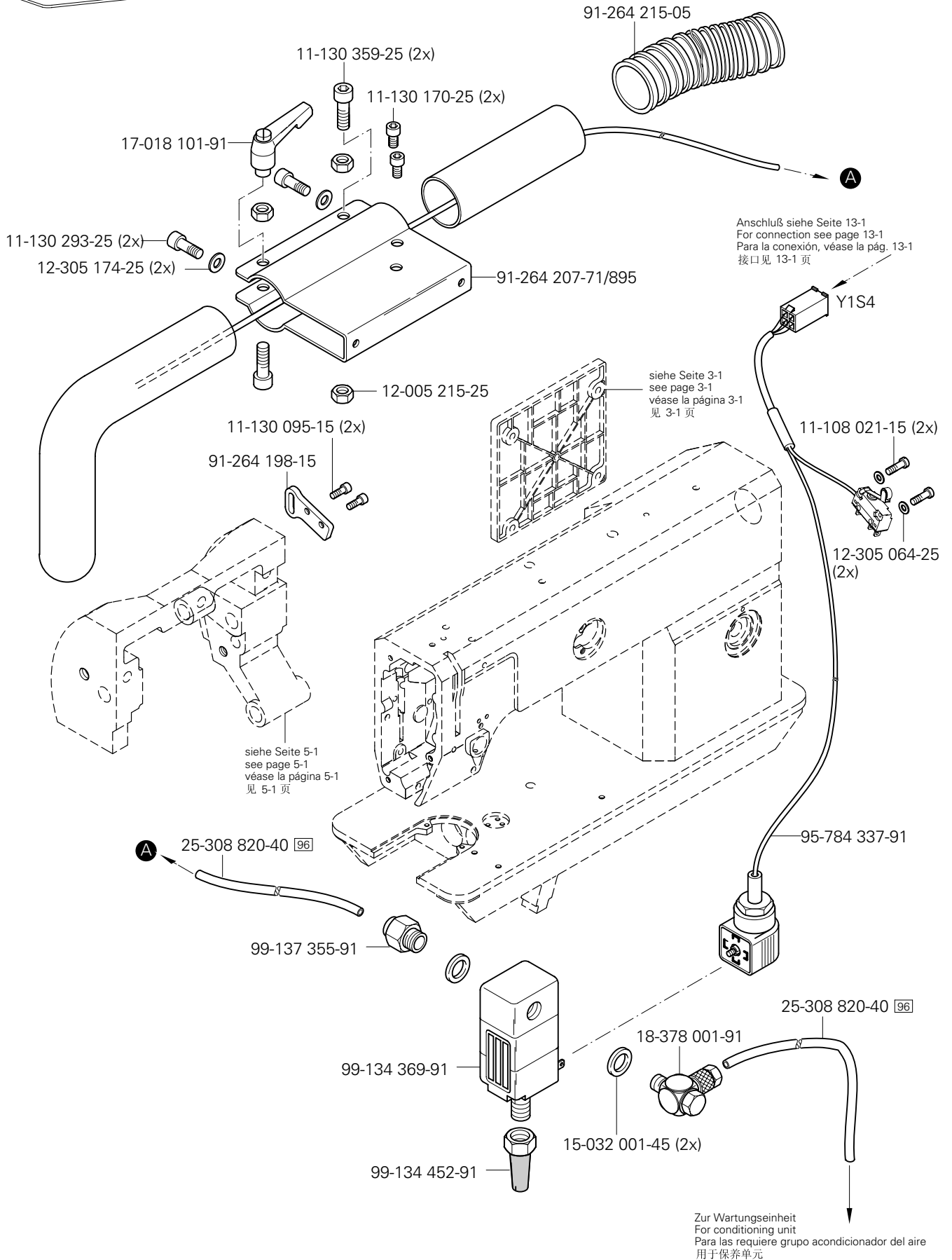

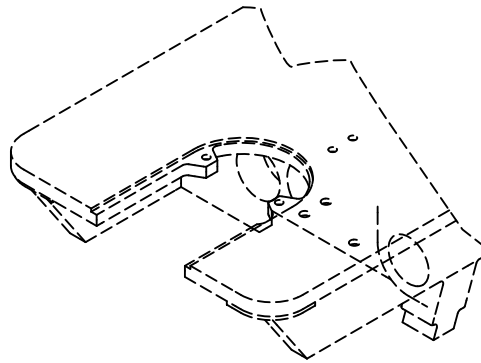
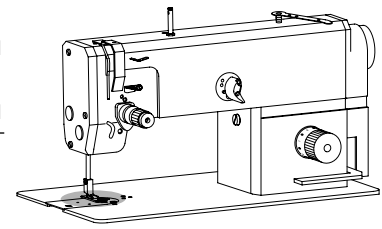

95-774 525-91 (PFAFF 1181-D;  
PFAFF 1181)

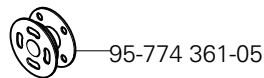
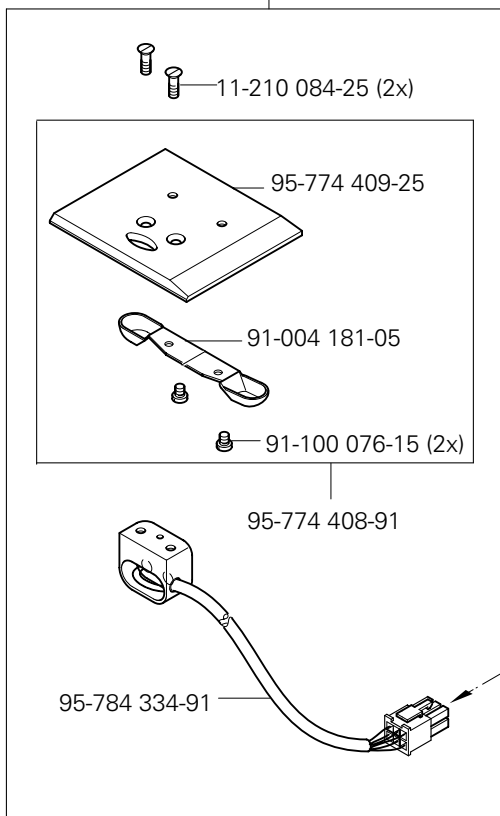

95-774 524-91 (PFAFF 1183-D;  
PFAFF 1183)

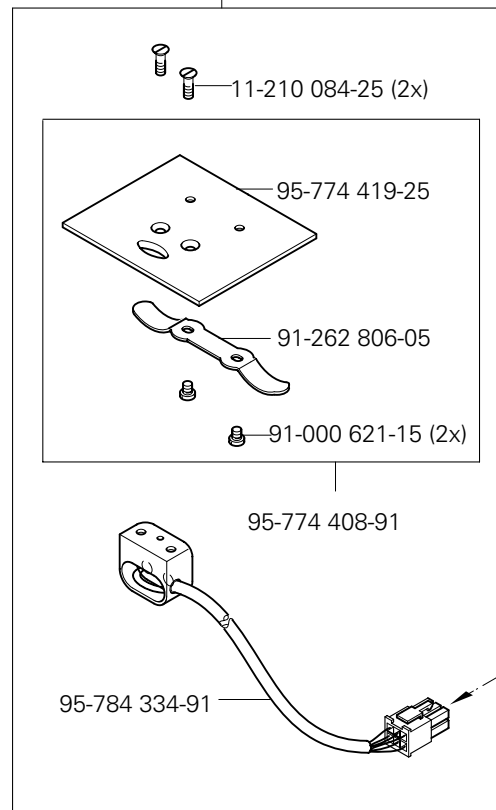

Anschluß siehe Seite 13-10  
 For connection see page 13-10  
 Para la conexión, véase la pág. 13-10  
 接口见 13-10页

Anschluß siehe Seite 13-10  
 For connection see page 13-10  
 Para la conexión, véase la pág. 13-10  
 接口见 13-10页



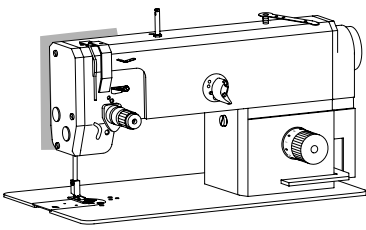

Walzentransport-Einrichtung (-948/51)  
 Puller feed (-948/51)  
 Puller (-948/51)  
 滚筒送料器 (-948/51)

PFAFF 1181-900/24;1181- D-900/24  
 PFAFF 1183-900/24;1183- D-900/24

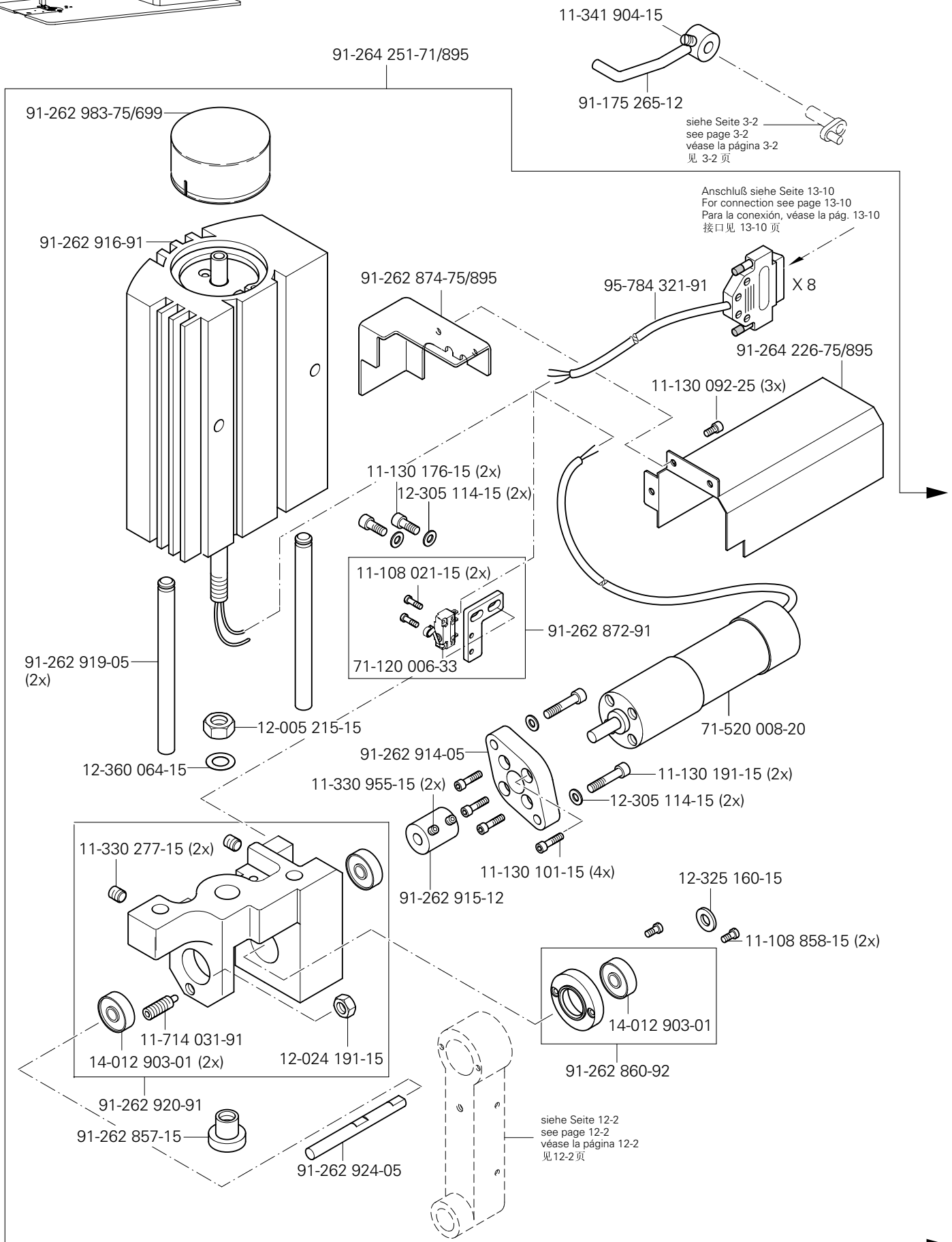

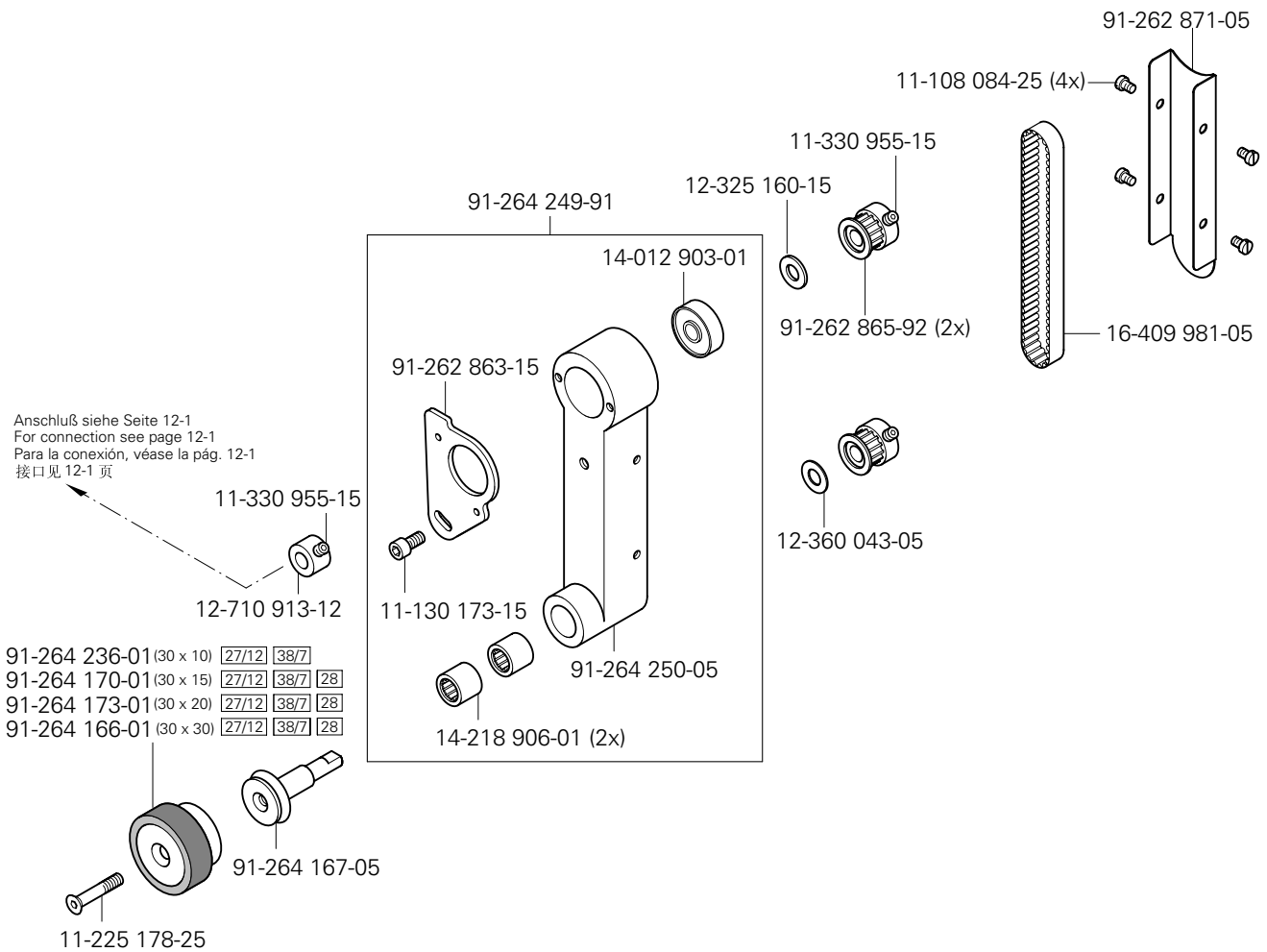
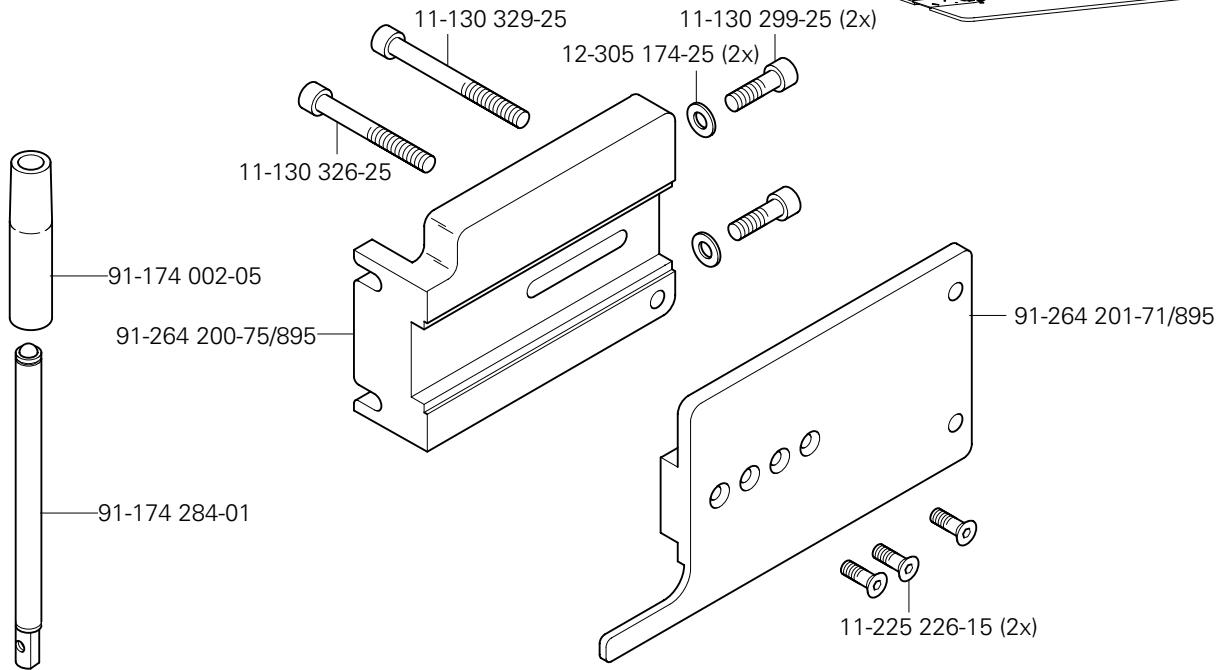
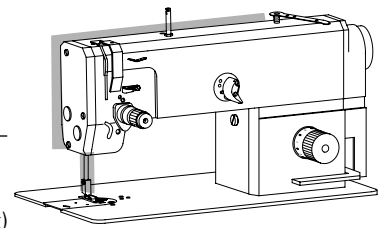



Kabelbaum zum Oberteil PFAFF 1181-900/24;1181-D-900/24  
 Cable tree to sewing head PFAFF 1183-900/24;1183-D-900/24  
 Mazo de cables para el cabezal PFAFF 1183-900/24;1183-D-900/24  
 上部机器电缆束

13.01

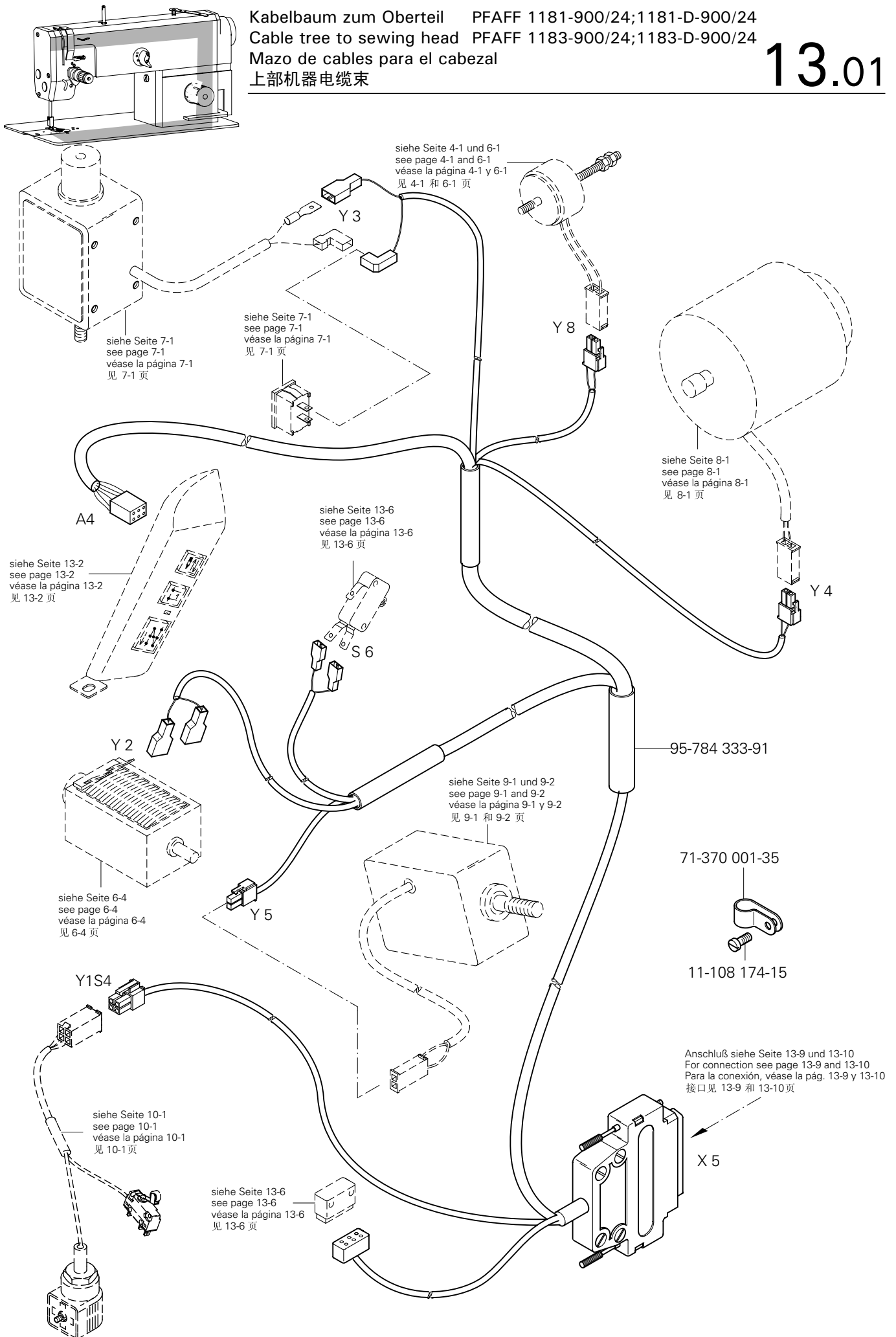

13.02 Tastschalter  
Push-button  
Interruptor pulsador  
按钮开关

PFAFF 1181-911/37;1181- D-911/37  
PFAFF 1183-911/37;1183-D-911/37

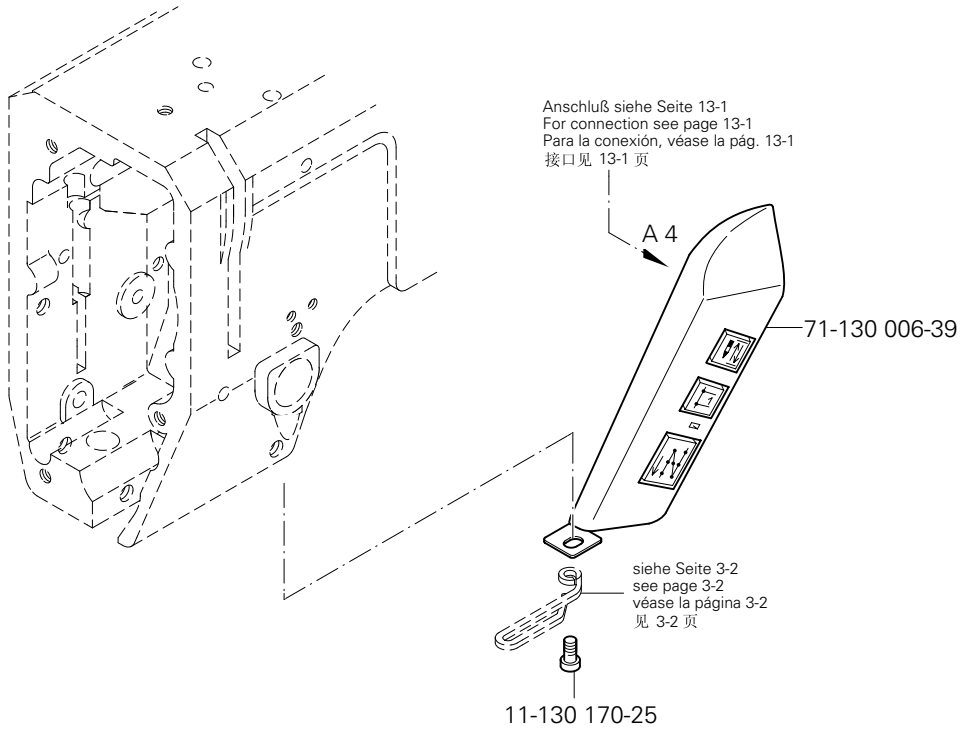
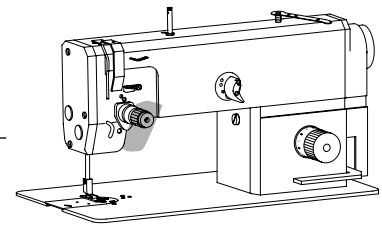

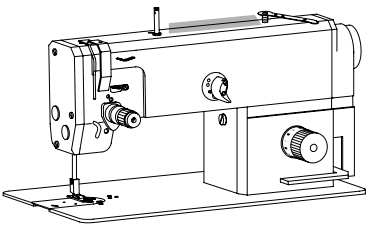

Bedienfeld  
Control panel  
Panel de mandos  
操作板

PFAFF 1181-900/24; 1181- D-900/24  
PFAFF 1183-900/24; 1183- D-900/24

13.03

71-590 007-70 Für -SRP; -948/51 siehe Seite 13-4  
For -SRP; -948/51 see page 13-4  
Para -SRP; -948/51 véase la página 13-4  
适于 -SRP; -948/51 见 13-4 页

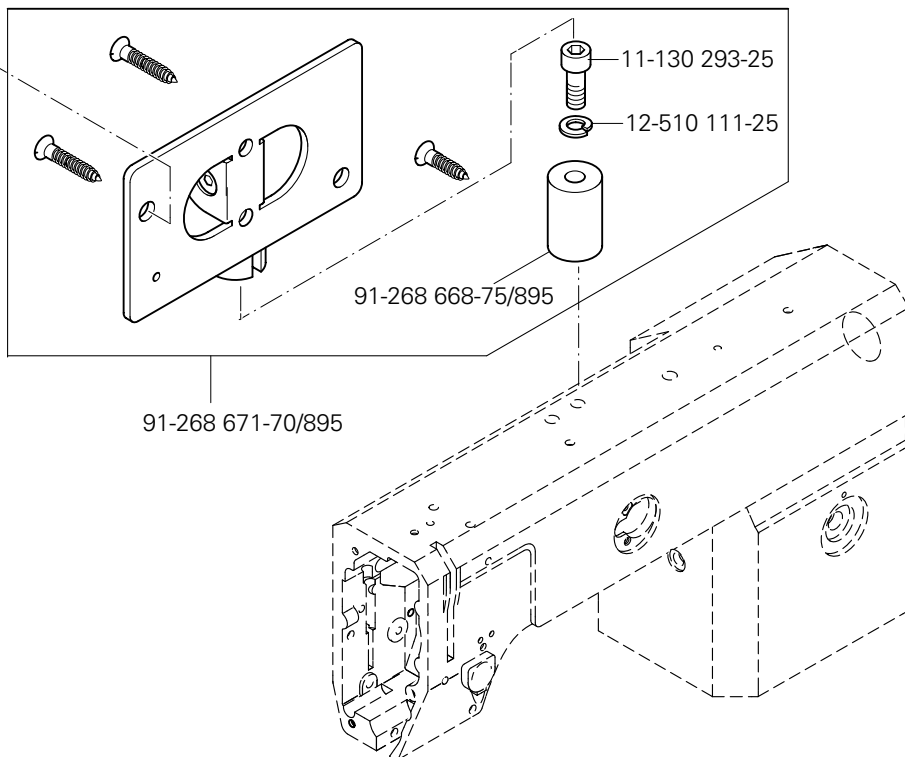
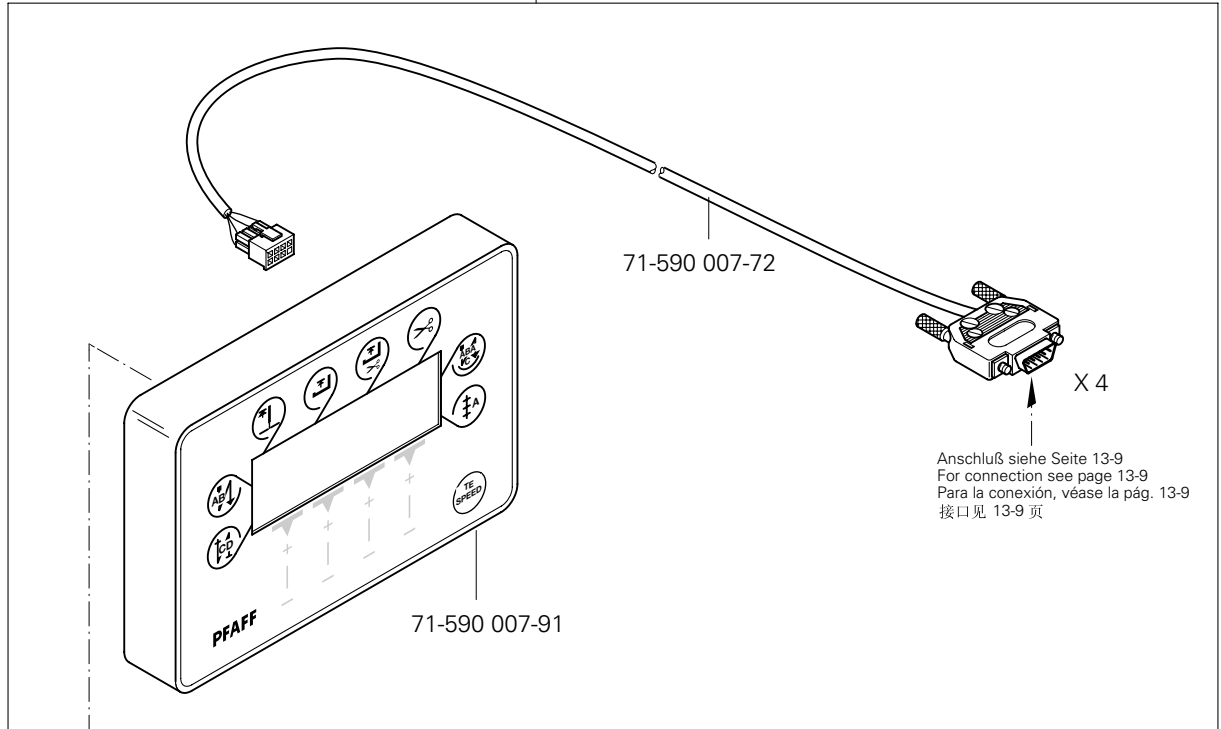

# 13.03

Bedienfeld PFAFF 1181-SRP-900/24;-900/24-948/51  
 Control panel PFAFF 1181-D-SRP-900/24;-900/24-948/51  
 Panel de mandos PFAFF 1183-SRP-900/24;-900/24-948/51  
 操作板 PFAFF 1183-D-SRP-900/24;-900/24-948/51

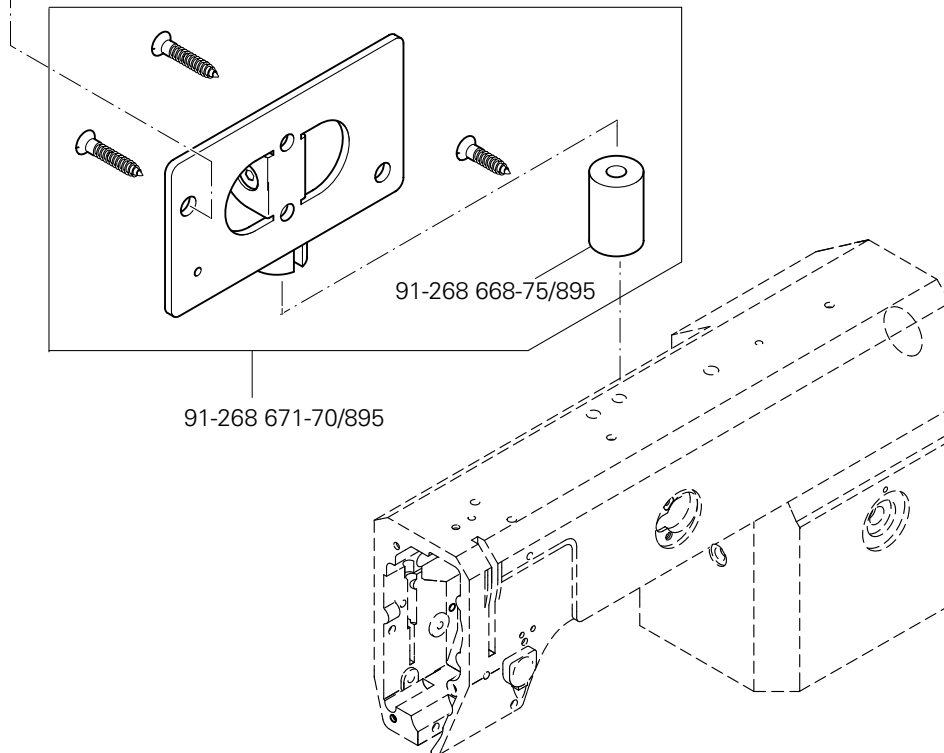
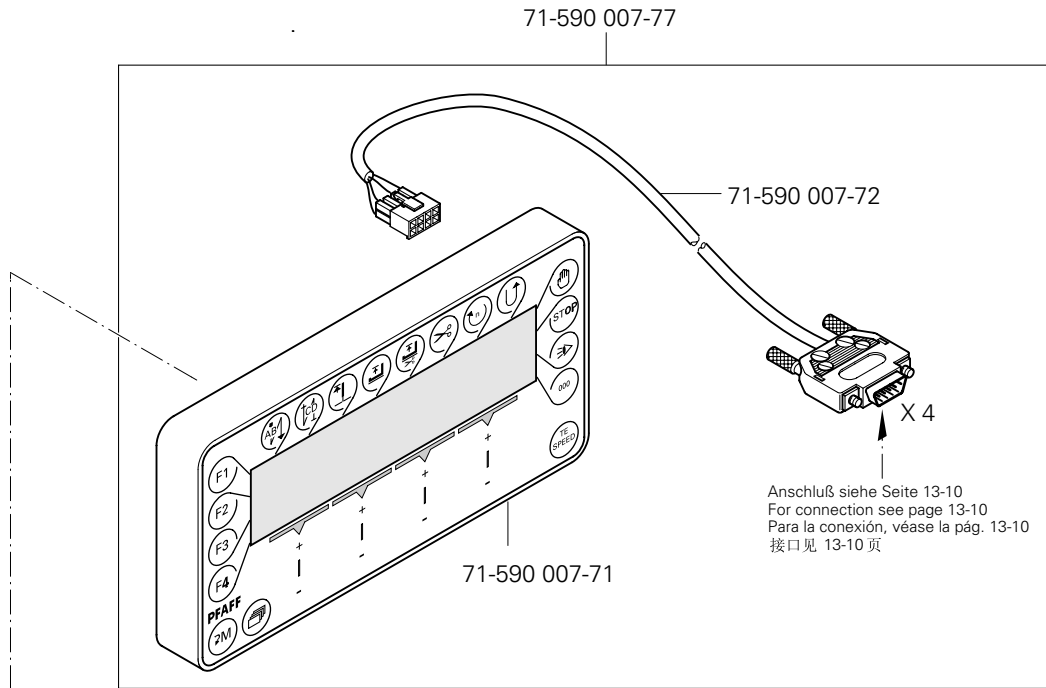
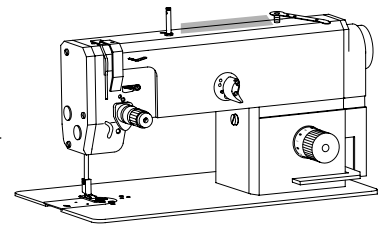

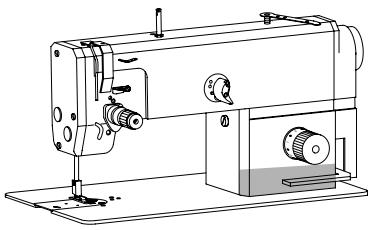

Einbaumotor  
Built-in motor

Motor incorporado  
内装式电机

PFAFF 1181-900/24; 1181- D-900/24  
PFAFF 1183-900/24; 1183- D-900/24

# 13.04

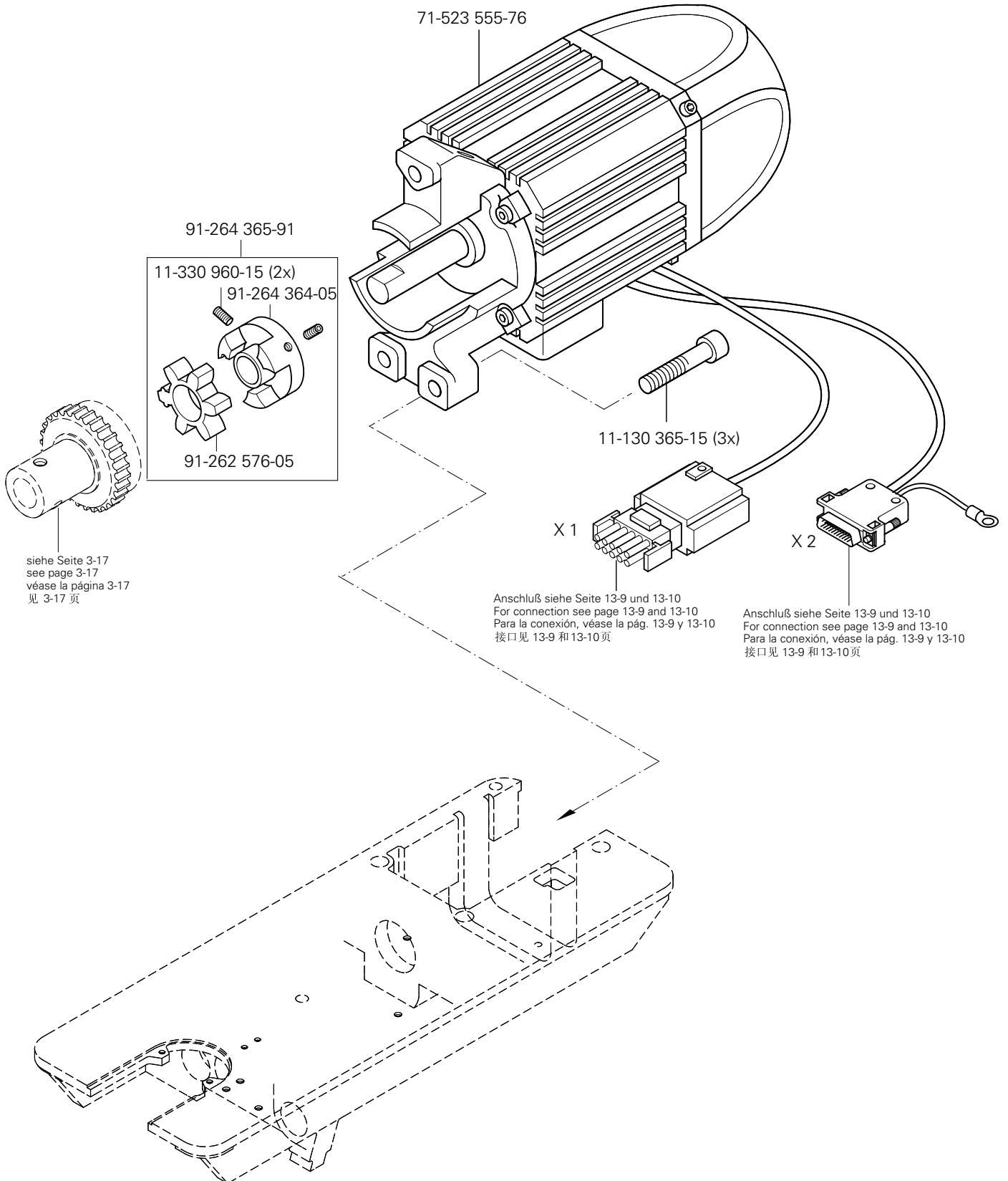

siehe Seite 3-17  
see page 3-17  
véase la página 3-17  
见 3-17 页

Anschluß siehe Seite 13-9 und 13-10  
For connection see page 13-9 and 13-10  
Para la conexión, véase la pág. 13-9 y 13-10  
接口见 13-9 和 13-10 页

Anschluß siehe Seite 13-9 und 13-10  
For connection see page 13-9 and 13-10  
Para la conexión, véase la pág. 13-9 y 13-10  
接口见 13-9 和 13-10 页

# 13.05

Oberteilerkennung und Einschaltperre  
 Sewing head identification and start inhibitor  
 Detección de la parte superior y bloqueo de arranque  
 上部机器识别和启动闭锁

PFAFF 1181-900/24  
 PFAFF 1181-D-900/24  
 PFAFF 1183-900/24  
 PFAFF 1183-D-900/24

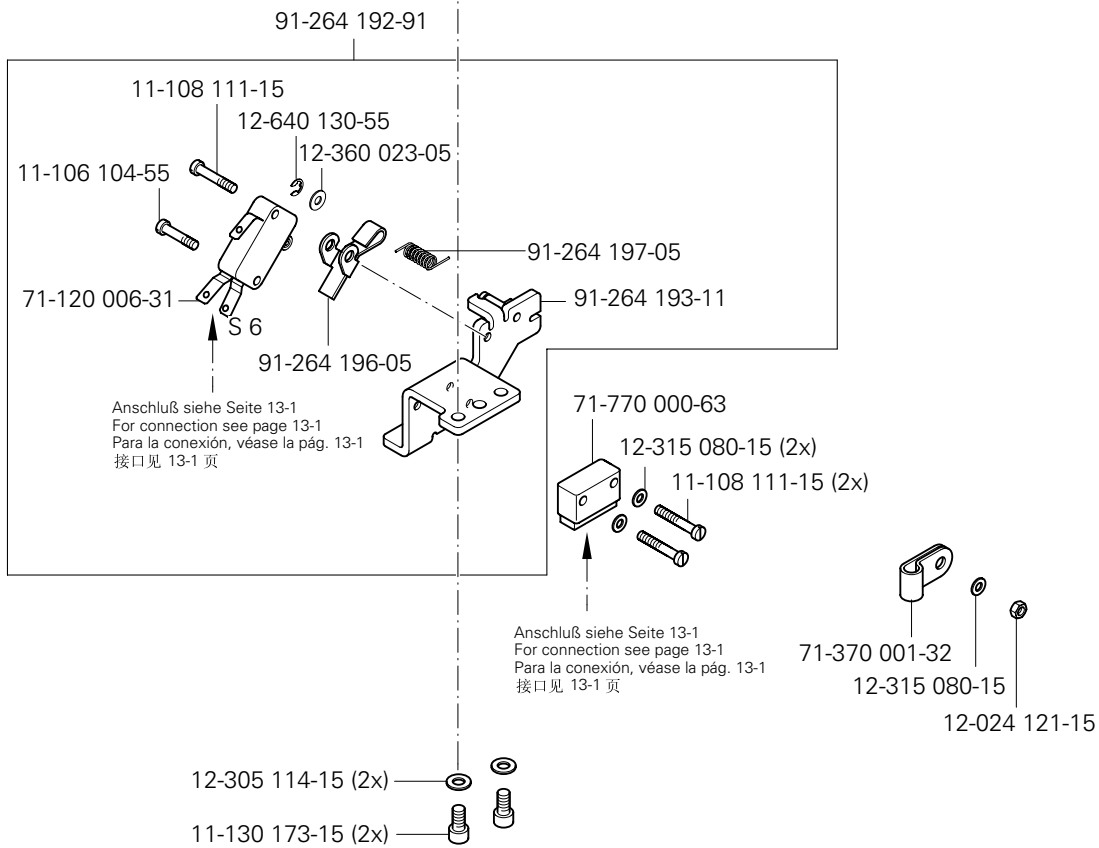
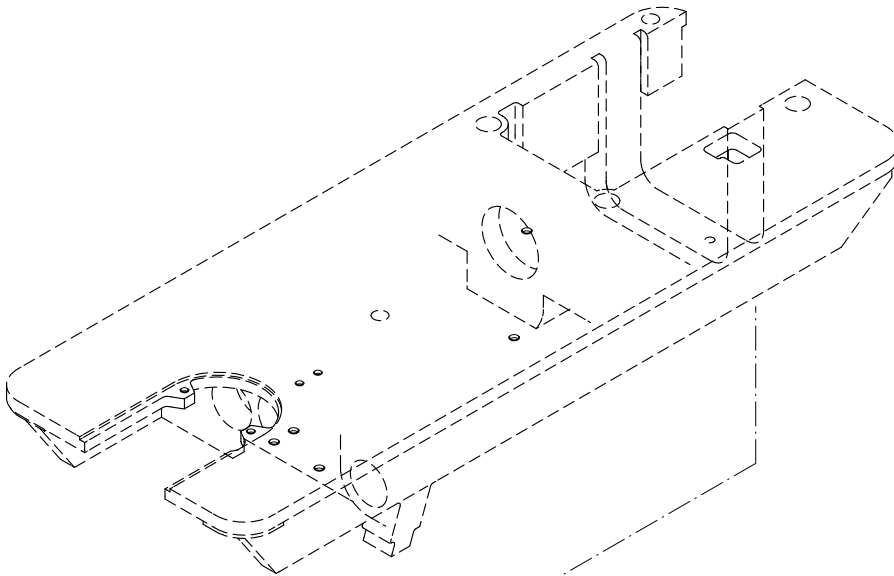
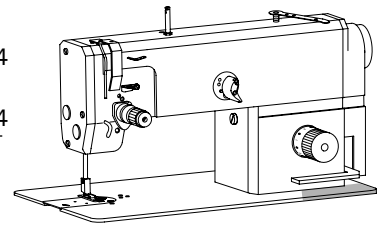

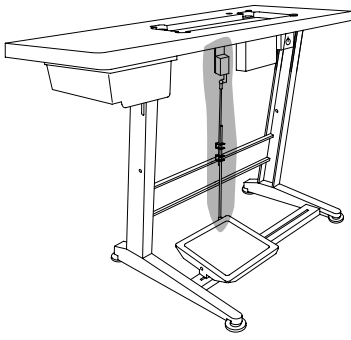

Sollwertgeber PFAFF 1181-900/24;1181- D-900/24  
 Set-point generator PFAFF 1183-900/24;1183- D-900/24  
 Emisor del valor teórico  
 给定值发生器

13.06

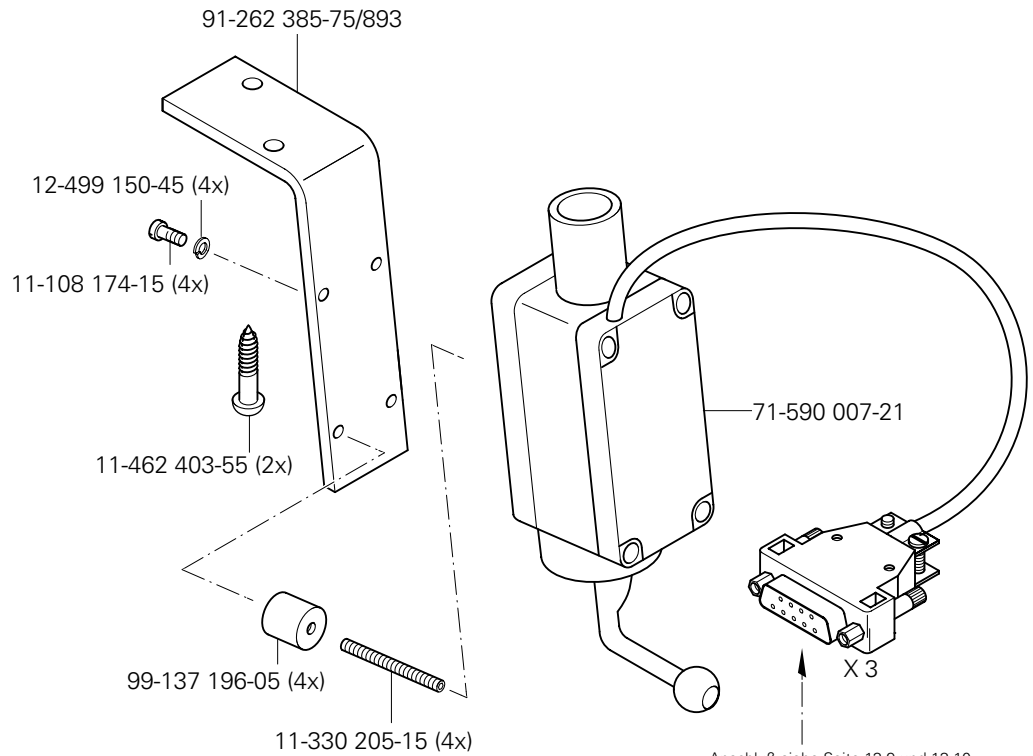

Anschluß siehe Seite 13-9 und 13-10  
 For connection see page 13-9 and 13-10  
 Para la conexión, véase la pág. 13-9 y 13-10  
 接口见 13-9 和 13-10 页

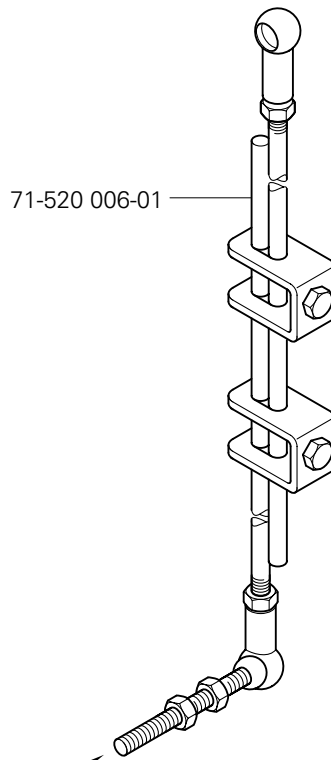

Zur Tretplatte  
 For the pedal  
 Para el pedal  
 用于踏板

# 13.07

Motor-Hauptschalter  
Main switch  
Interruptor principal  
电机主开关

PFAFF 1181;1181- D  
PFAFF 1183;1183- D

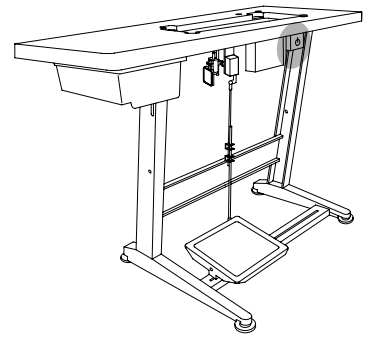

71-370 001-08



11-460 163-15

Anschluß siehe Seite 13-9 und 13-10  
For connection see page 13-9 and 13-10  
Para la conexión, véase la pág. 13-9 y 13-10  
接口见 13-9 和 13-10 页

91-229 180-90 90/1

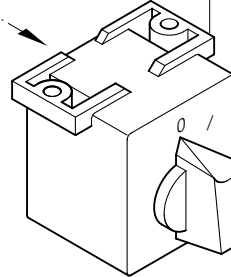

71-370 002-92



11-460 250-15 (2x)

# 13.08

Knietaster mit Leitung  
Knee switch with cable  
Interruptor de rodillera con cable  
带电缆膝键

PFAFF1181 SRP-900/24  
PFAFF1181-D-SRP-900/24  
PFAFF1183 SRP-900/24  
PFAFF1183-D-SRP-900/24

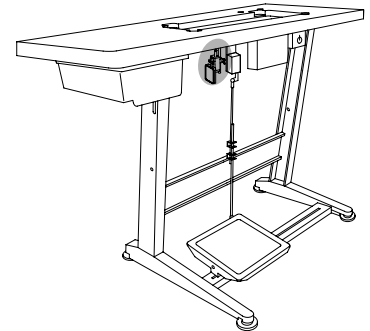

91-091 606-91

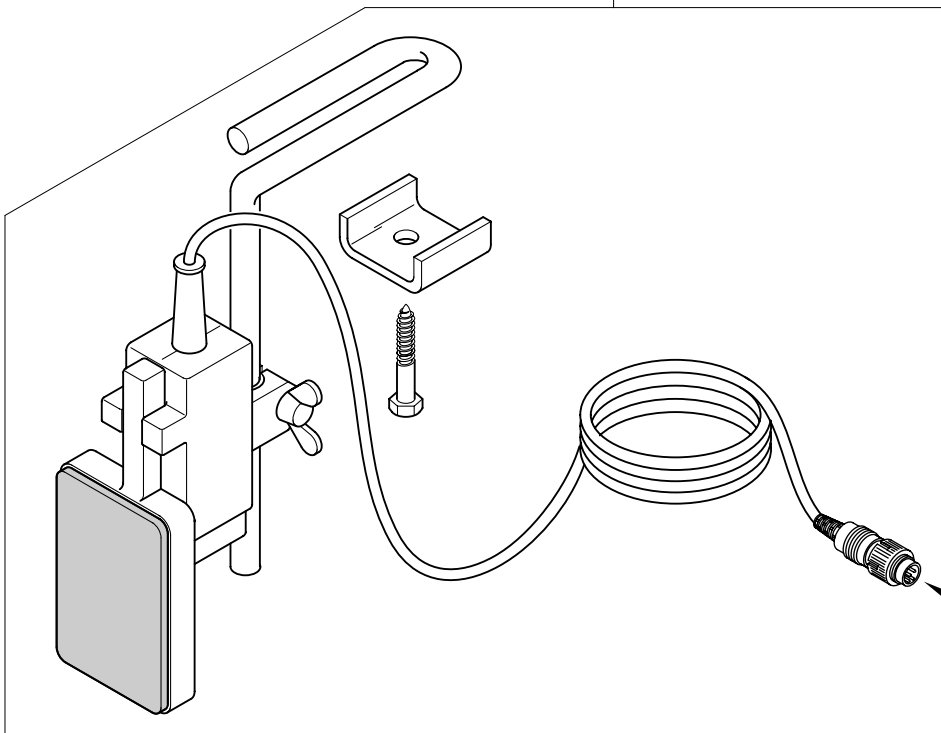

Anschluß siehe Seite 4-3  
For connection see page 4-3  
Para la conexión, véase la pág. 4-3  
接口见 4-3 页



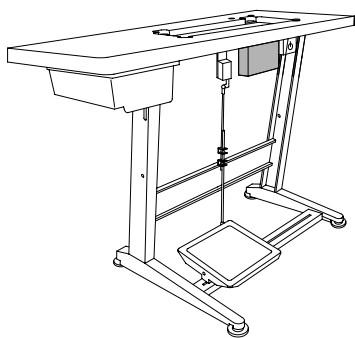

Steuerkasten  
Control box  
Caja de mandos  
控制箱

PFAFF 1181-900/24;1181- D-900/24  
PFAFF 1183-900/24;1183- D-900/24

13.09

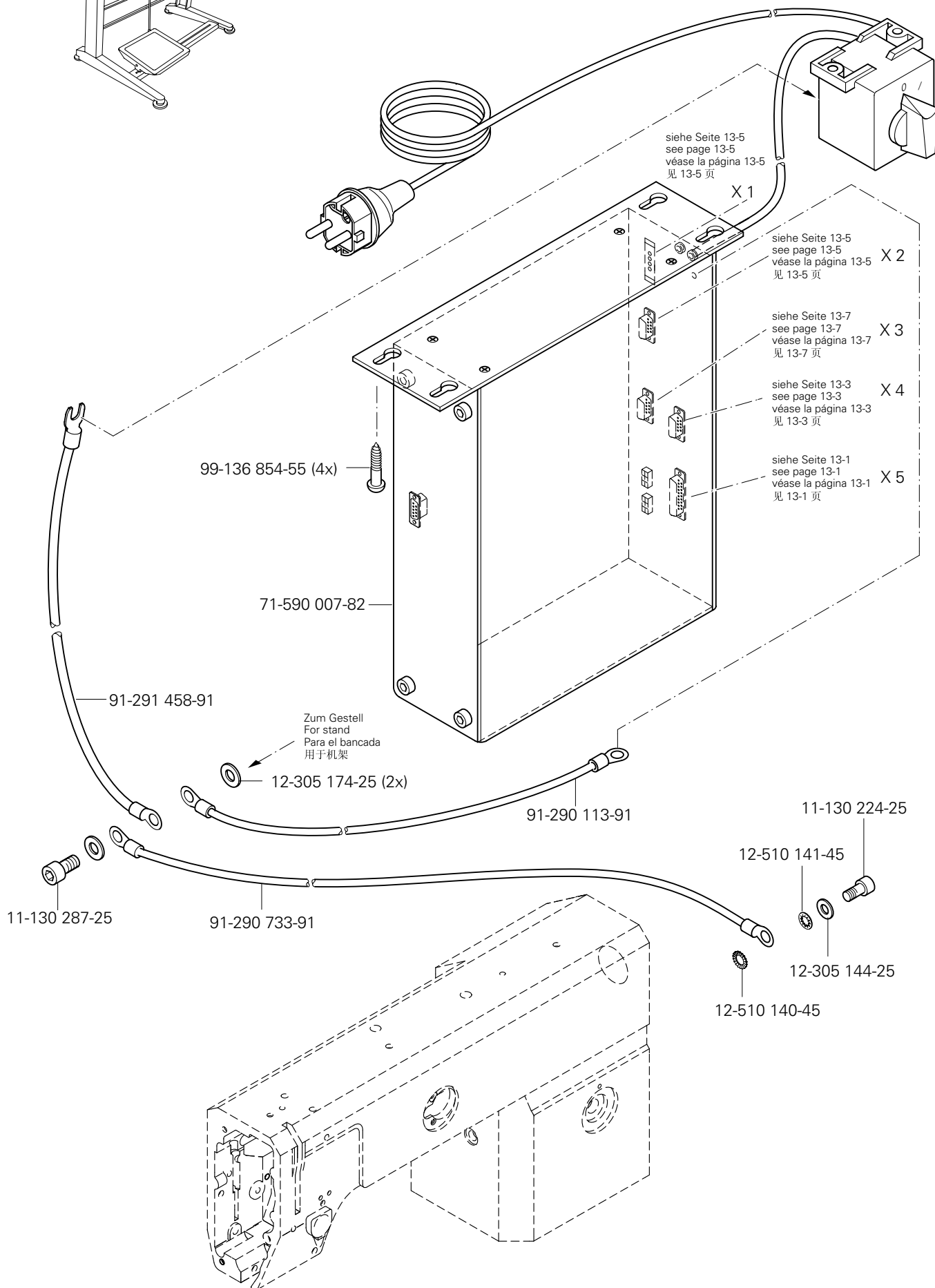

# 13.09

Steuerkasten

Control box

Caja de mandos

控制箱

PFAFF 1181 SRP-900/24;-900/24-948/51

PFAFF 1181-D-SRP-900/24;-900/24-948/51

PFAFF 1183 SRP-900/24;-900/24-948/51

PFAFF 1183-D-SRP-900/24;-900/24-948/51

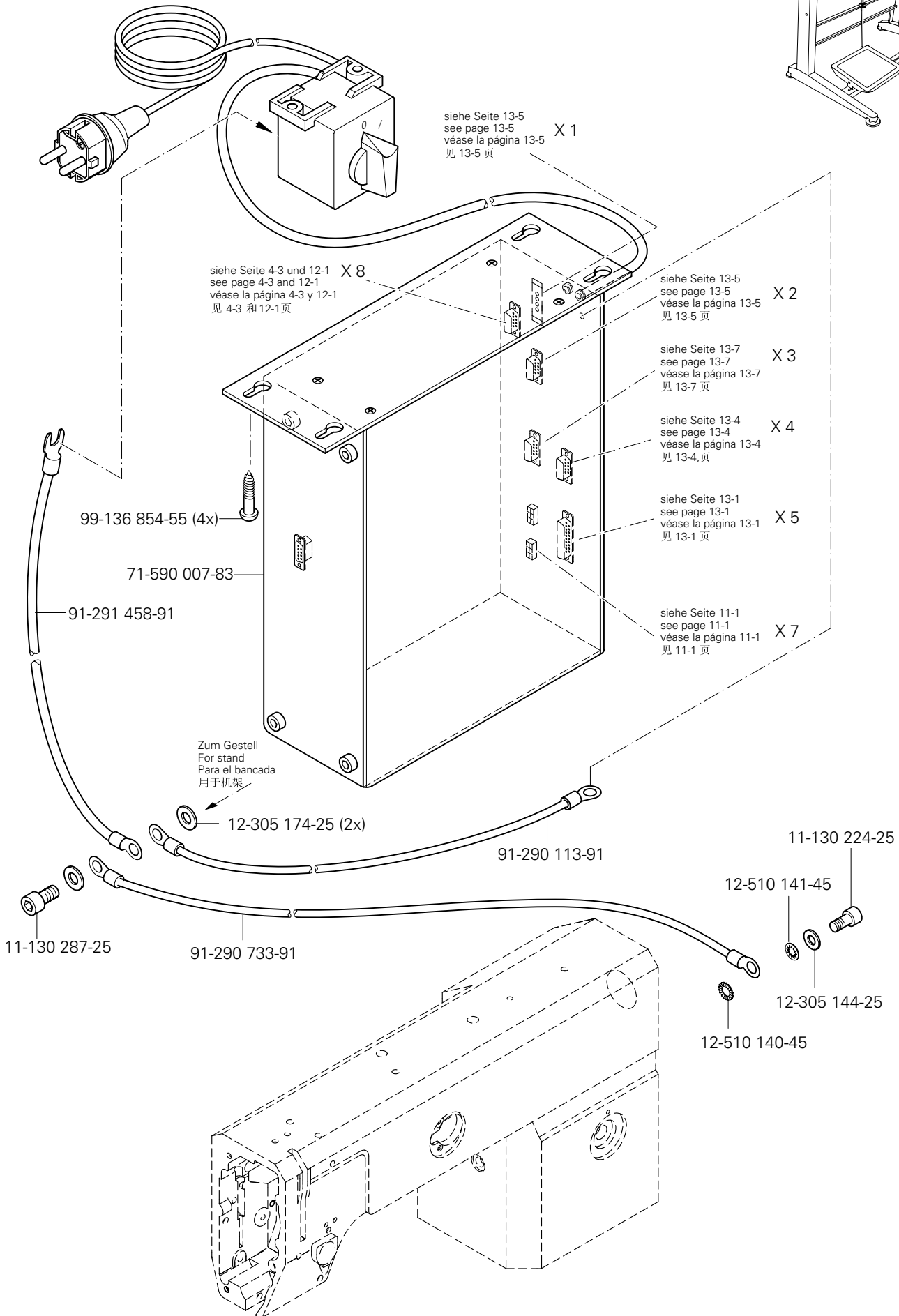
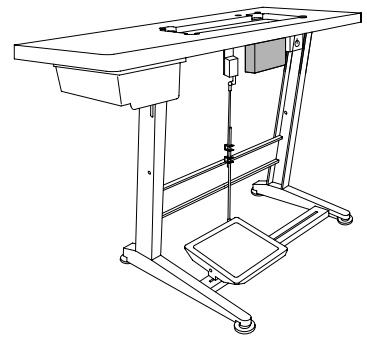

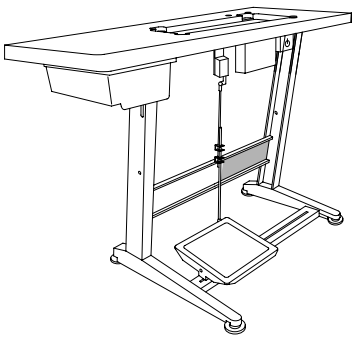

Wartungseinheit  
 Air filter / lubricator  
 Grupo acondicionador del aire comprimido  
 保养单元

PFAFF 1181-731/01-920/06  
 PFAFF 1181-D-731/01-920/06  
 PFAFF 1183-731/01-920/06  
 PFAFF 1183-D-731/01-920/06

siehe Seite 10-1  
 see page 10-1  
 véase la página 10-1  
 见 10-1 页

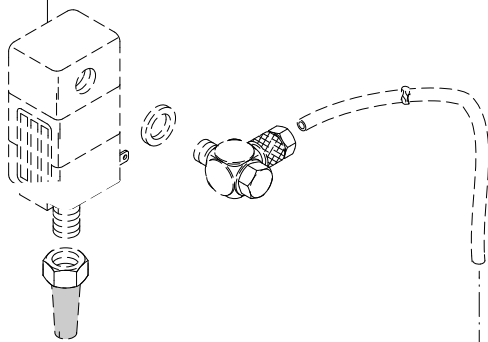

91-187 426-70/893

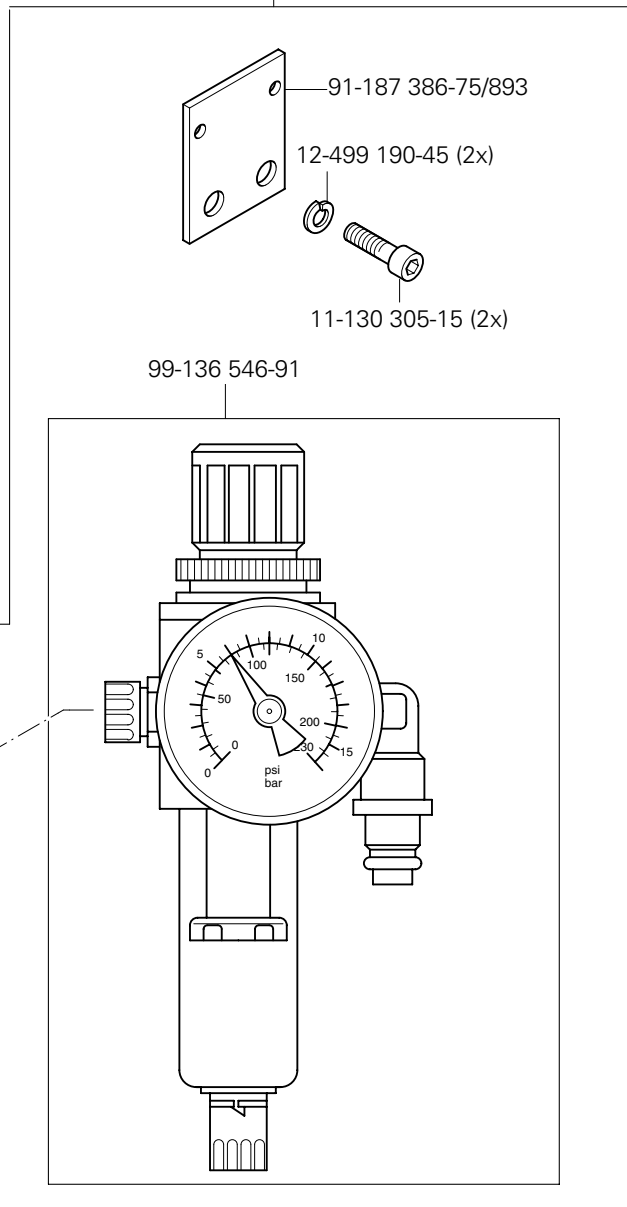

15-032 002-45

18-372 003-91

91-187 386-75/893

12-499 190-45 (2x)

11-130 305-15 (2x)

99-136 546-91

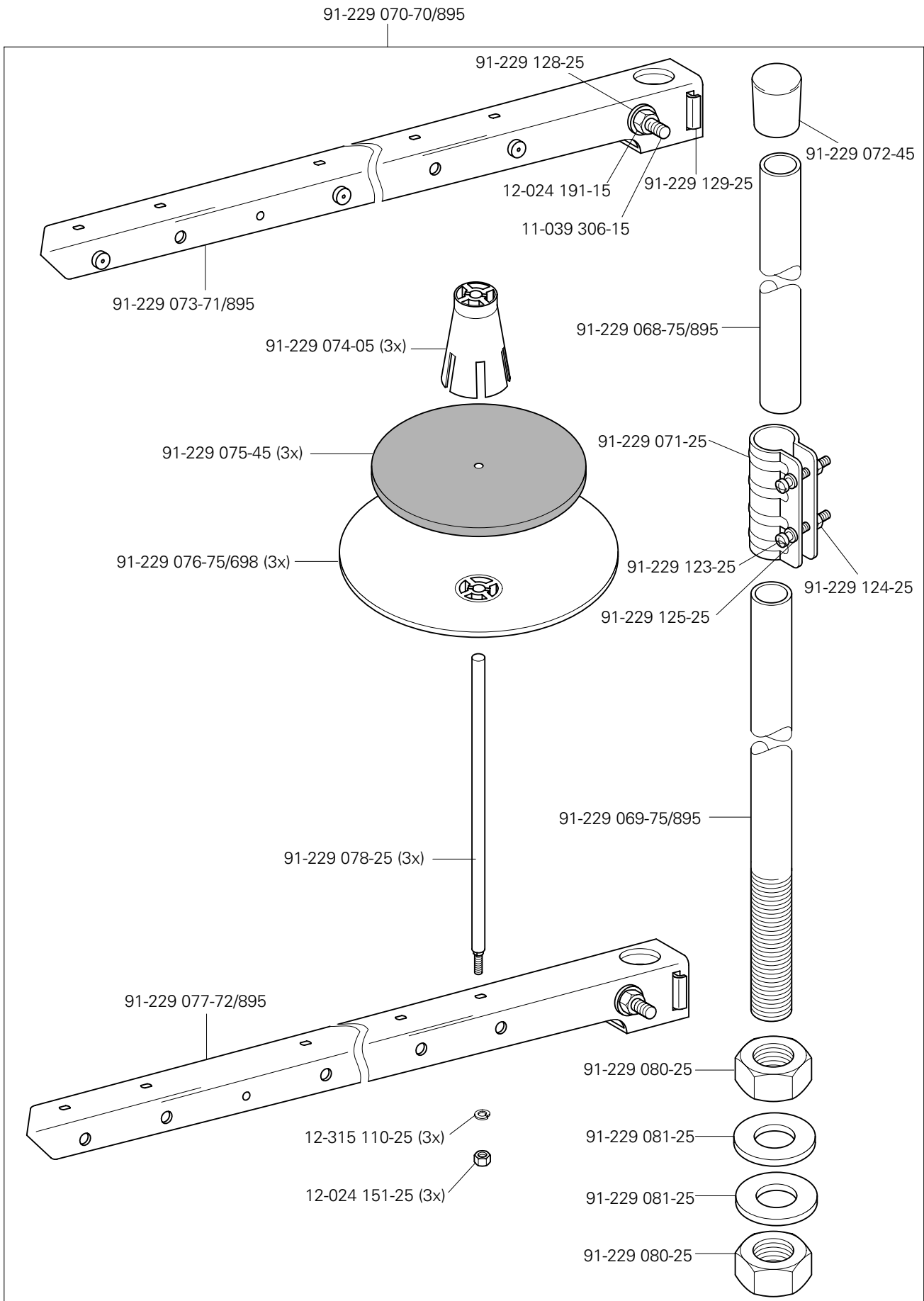

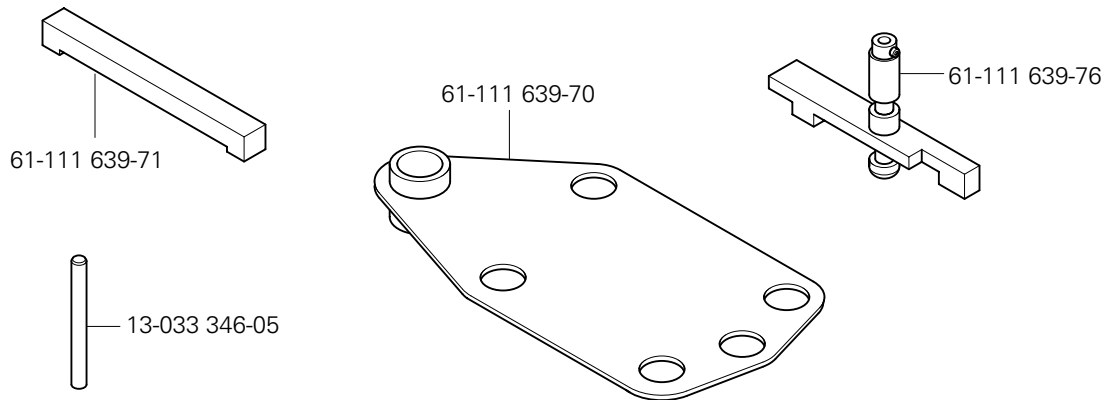

Teile zur Tischplatte  
Parts for table top

Piezas para el tablero PFAFF 1181;1181- D  
用于台板的零件 PFAFF 1183;1183- D

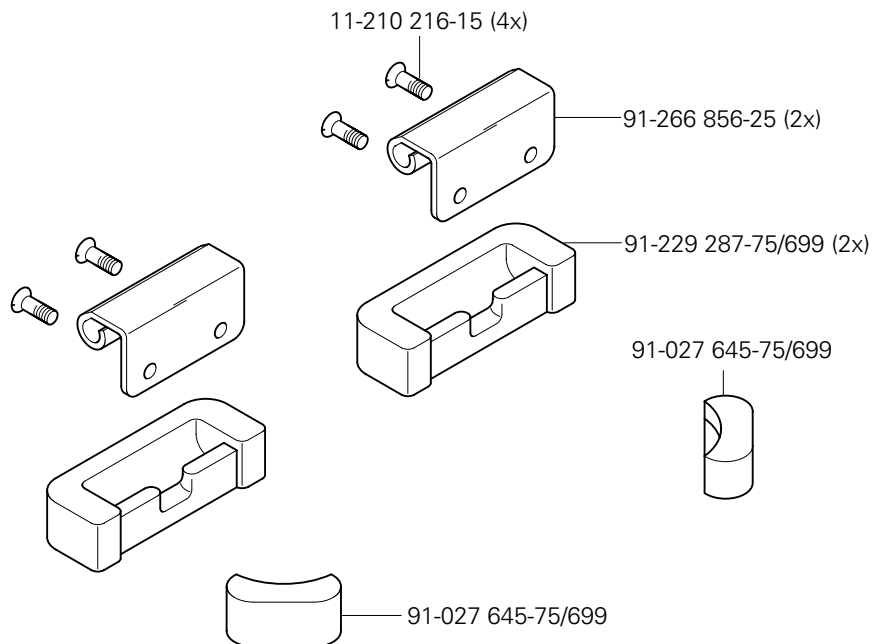

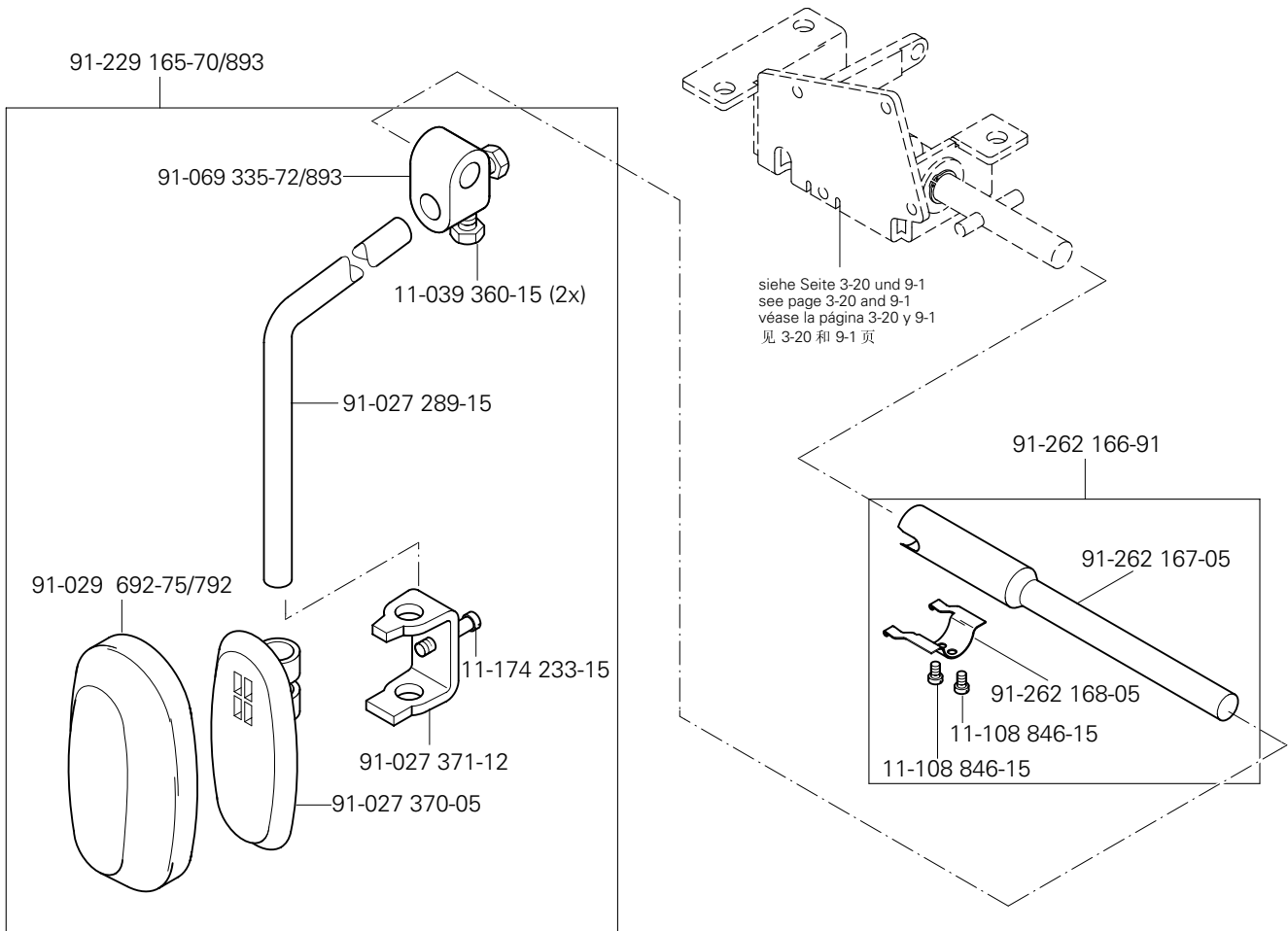
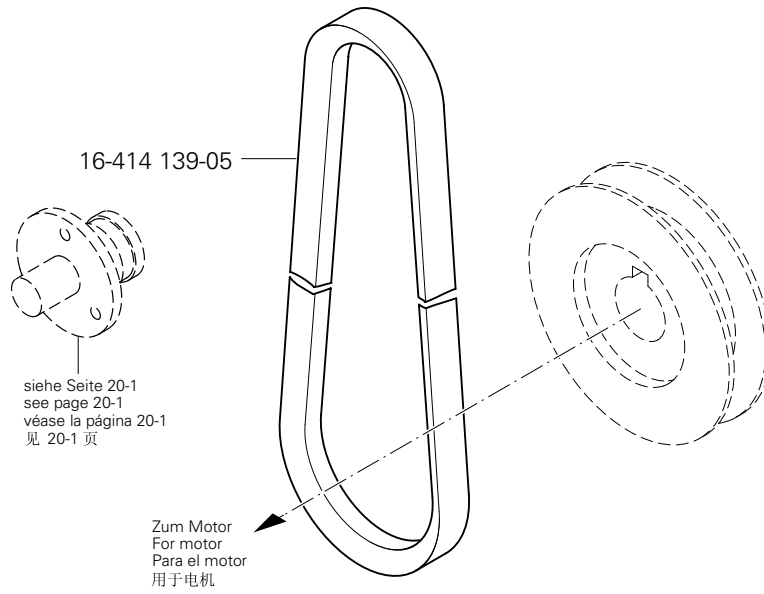

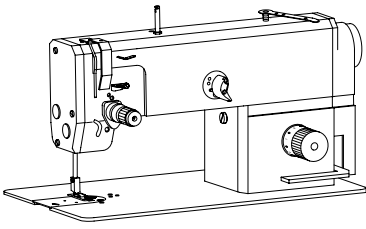

Anbausatz für externen Motor  
 Mounting kit for external motor  
 Juego de piezas acoplables para motor externo  
 外部电机安装组件

PFAFF 1181  
 PFAFF 1181- D  
 PFAFF 1183  
 PFAFF 1183- D

20.01

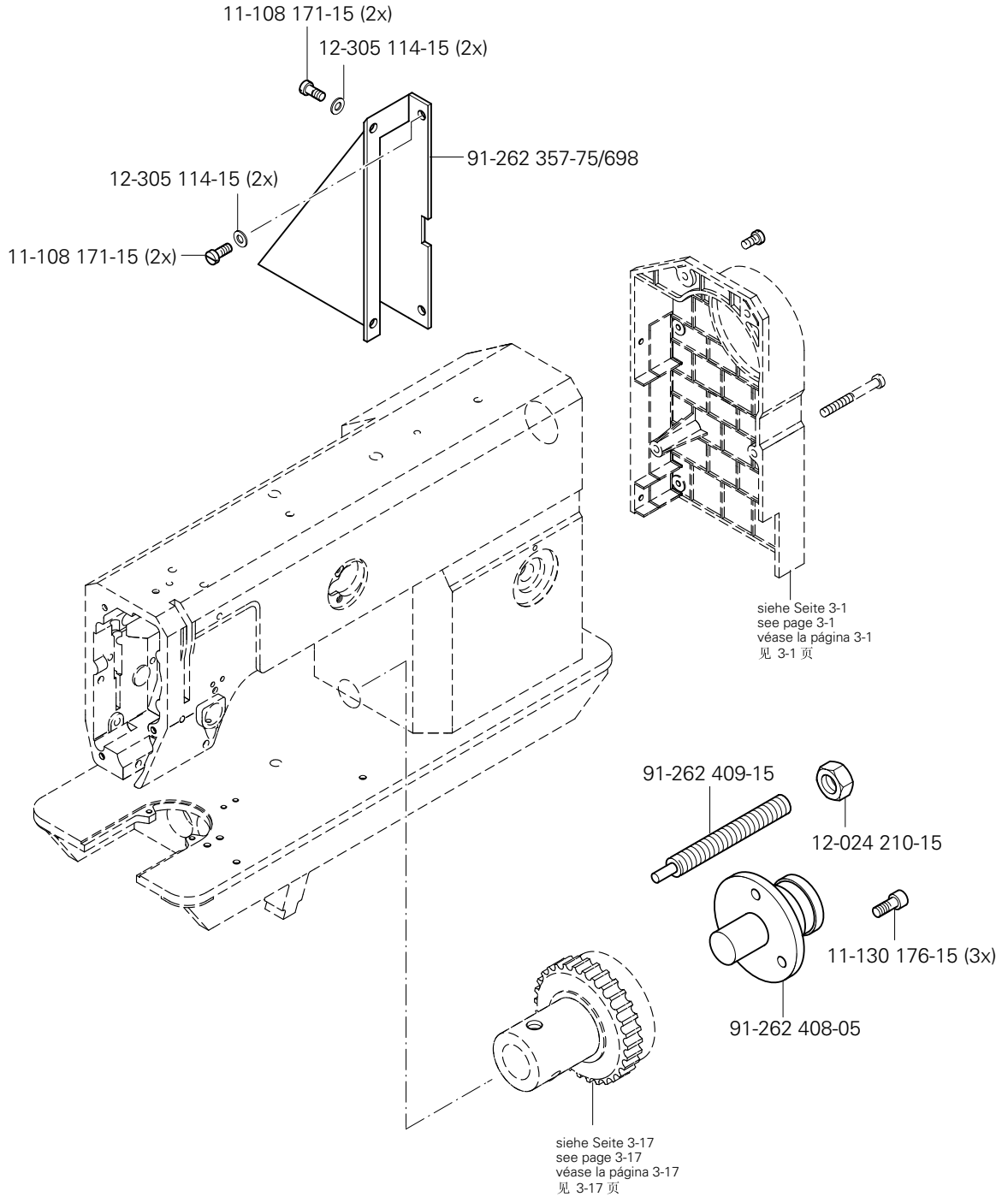

Öl Oil Aceite 油	Mittelpunkts-Viskosität bei: Mean viscosity at: Viscosidad media a: 中点粘度:		Dichte bei: Density of: Densidad a: 密度, 在:		Bestellnummer für Behälter mit: Part number for can with: Número de pedido para recipientes con: 订货号用于油箱, 带:		
	°C	mm <sup>2</sup> /s	°C	g/cm <sup>3</sup> (g/ml)	1 Liter 1 Litre 1 Litro 1 升	5 Liter 5 Litre 5 Litros 5 升	10 Liter 10 Litre 10 Litros 10 升
28-011 201-05	40	10,0	15	0,847	91-027 975-91	91-027 976-91	91-027 977-91

Fett Grease Grasa 脂	Penetration Penetration Penetración 贯入度	Tropfpunkt Drip-point Punto de goteo 滴点	Bestellnummer für Behälter mit: Part number for can with: Número de pedido para recipientes con: 订货号用于油箱, 带:				
			mm/10	°C	0,25 kg	0,5 kg	1 kg
28-011 202-05							28-011 202-05
28-011 202-47	220-250	185					28-011 202-47

Reinigungsmittel Cleansing agent Limpiadores 清洁剂	Bestellnummer für Behälter mit: Part number for can with: Número de pedido para recipientes con: 订货号用于油箱, 带:		
	240 ml		
Isopropyl-Alkohol	95-665 735-91		



No. 序号	Seite Page Página 页号	No. 序号	Seite Page Página 页号	No. 序号	Seite Page Página 页号	No. 序号	Seite Page Página 页号
11-039 306-15	15 - 1	11-130 191-15	12 - 1	11-210 084-25	11 - 1	11-330 962-15	3 - 14
11-039 360-15	18 - 1	11-130 203-15	4 - 2	11-210 168-25	3 - 13	11-330 964-15	3 - 6, 3 - 17
11-039 378-15	8 - 1	11-130 224-15	3 - 8, 3 - 12, 3 - 17, 3 - 20,	11-210 178-15	7 - 1	11-330 968-15	3 - 17
11-106 104-55	13 - 6		4 - 1, 5 - 1, 6 - 1, 9 - 1	11-210 216-15	16 - 1	11-335 085-15	6 - 2, 6 - 3
11-108 021-15	12 - 1	11-130 224-25	3 - 1, 13 - 9, 13 - 10	11-210 265-15	3 - 6	11-335 280-15	3 - 6, 3 - 9, 3 - 11, 3 - 17
11-108 021-18	10 - 1	11-130 227-15	3 - 10, 5 - 2	11-225 172-25	3 - 1	11-341 277-15	3 - 2, 3 - 4, 3 - 5
11-108 084-15	6 - 2, 6 - 3	11-130 233-15	4 - 3, 5 - 1	11-225 178-25	12 - 2	11-341 901-15	3 - 4
11-108 084-25	12 - 2	11-130 233-25	7 - 1	11-225 220-15	4 - 2	11-341 902-15	3 - 17
11-108 087-15	6 - 2, 6 - 3	11-130 251-15	3 - 1	11-225 223-15	3 - 3	11-341 904-15	3 - 2, 7 - 1, 12 - 1
11-108 096-15	5 - 2	11-130 257-25	3 - 1	11-225 226-15	12 - 2	11-460 163-15	13 - 8
11-108 111-15	13 - 6	11-130 284-15	3 - 14	11-225 232-15	3 - 2, 4 - 1, 6 - 1	11-460 250-15	13 - 8
11-108 135-15	5 - 1	11-130 287-15	3 - 8, 3 - 9, 3 - 10, 3 - 20,	11-250 084-25	3 - 13	11-462 403-55	13 - 7
11-108 171-15	20 - 1		6 - 4, 9 - 1, 9 - 2	11-301 761-55	12 - 1	11-714 031-91	12 - 1
11-108 174-15	13 - 1, 13 - 7	11-130 287-25	13 - 9, 13 - 10	11-317 971-15	3 - 4	12-005 154-15	4 - 1, 6 - 1, 7 - 1
11-108 174-25	3 - 2	11-130 293-15	3 - 1, 9 - 1, 9 - 2	11-320 171-15	3 - 10	12-005 175-15	3 - 9, 3 - 10
11-108 177-15	3 - 19, 7 - 1	11-130 293-25	10 - 1, 13 - 3	11-330 085-15	3 - 3	12-005 195-15	5 - 1, 7 - 1
11-108 180-15	7 - 1	11-130 299-25	12 - 2	11-330 166-15	3 - 8	12-005 215-15	8 - 1, 9 - 1, 9 - 2, 12 - 1
11-108 222-15	3 - 15, 3 - 16, 6 - 2, 6 - 3	11-130 305-15	14 - 1	11-330 175-15	3 - 13, 6 - 1	12-005 215-25	10 - 1
11-108 222-25	3 - 1	11-130 305-25	4 - 2	11-330 205-15	13 - 7	12-024 121-15	13 - 6
11-108 285-15	7 - 1	11-130 326-25	12 - 2	11-330 217-15	3 - 15, 3 - 16, 5 - 2, 6 - 2, 6 - 3	12-024 151-25	15 - 1
11-108 846-15	18 - 1	11-130 329-25	12 - 2	11-330 220-15	3 - 2, 3 - 3, 3 - 4, 3 - 5, 5 - 1	12-024 171-15	3 - 20, 9 - 1
11-108 858-15	12 - 1	11-130 359-25	10 - 1	11-330 232-15	3 - 20, 9 - 1	12-024 191-15	4 - 2, 5 - 1, 12 - 1, 15 - 1
11-130 086-15	4 - 1, 6 - 1	11-130 365-15	13 - 5	11-330 277-15	3 - 6, 3 - 8, 3 - 10, 3 - 11, 3 - 12, 3 - 18, 5 - 3, 8 - 1, 12 - 1	12-024 191-25	3 - 13
11-130 092-25	12 - 1	11-132 172-15	3 - 2	11-330 280-15	3 - 6	12-024 210-15	20 - 1
11-130 095-15	10 - 1	11-132 223-15	3 - 2, 4 - 2	11-330 952-15	3 - 8, 3 - 12, 3 - 13, 3 - 14, 3 - 15, 3 - 16, 3 - 17, 3 - 20, 5 - 1, 6 - 2, 6 - 3, 6 - 4, 9 - 1	12-305 064-25	10 - 1
11-130 101-15	7 - 1, 12 - 1	11-170 281-15	3 - 7			12-305 114-15	3 - 5, 6 - 4, 12 - 1, 13 - 6, 20 - 1
11-130 167-15	4 - 2, 7 - 1	11-173 168-25	3 - 2			12-305 144-25	13 - 9, 13 - 10
11-130 170-25	3 - 1, 10 - 1, 13 - 2	11-174 176-15	5 - 1, 5 - 2	11-330 955-15	3 - 4, 4 - 2, 5 - 1, 12 - 1, 12 - 2	12-305 174-25	10 - 1, 12 - 2, 13 - 9, 13 - 10
11-130 173-15	3 - 1, 5 - 1, 5 - 2, 6 - 4, 12 - 2, 13 - 6	11-174 233-15	18 - 1			12-305 264-15	3 - 20, 9 - 1
11-130 176-15	3 - 5, 3 - 14, 5 - 1, 6 - 4, 9 - 1, 9 - 2, 12 - 1, 20 - 1	11-178 172-15	5 - 2			12-315 080-01	13 - 6
		11-178 223-25	3 - 10	11-330 958-15	5 - 3	12-315 080-15	13 - 6
		11-180 283-25	3 - 1, 5 - 1	11-330 960-15	13 - 5	12-315 110-25	15 - 1
11-130 185-15	3 - 1	11-210 081-15	7 - 1				

No. 序号	Seite Page Página 页号	No. 序号	Seite Page Página 页号	No. 序号	Seite Page Página 页号	No. 序号	Seite Page Página 页号
12-315 140-25	7 - 1	12-624 310-45	3 - 18	15-032 001-45	10 - 1	71-520 008-20	12 - 1
12-325 160-15	12 - 1, 12 - 2	12-640 090-55	5 - 1	15-032 002-45	14 - 1	71-523 555-76	13 - 5
12-335 171-15	3 - 9	12-640 130-55	3 - 2, 3 - 13, 4 - 1, 4 - 2, 13 - 6	16-409 981-05	12 - 2	71-590 007-21	13 - 7
12-341 090-25	3 - 12	12-640 150-45	3 - 7	16-409 983-05	3 - 17	71-590 007-70	13 - 3
12-349 901-05	3 - 16, 6 - 3	12-640 150-55	3 - 7, 3 - 10, 6 - 4, 7 - 1	16-414 139-05	18 - 1	71-590 007-71	13 - 4
12-360 023-05	7 - 1, 13 - 6	12-640 170-55	3 - 10, 5 - 1	17-018 101-91	10 - 1	71-590 007-72	13 - 3, 13 - 4
12-360 033-05	6 - 4	12-640 200-55	3 - 12, 5 - 1	18-372 003-91	14 - 1	71-590 007-77	13 - 4
12-360 043-05	4 - 2, 6 - 4, 12 - 2	12-660 390-45	3 - 15, 3 - 16, 6 - 2, 6 - 3	18-378 001-91	10 - 1	71-590 007-82	13 - 9
12-360 054-05	3 - 9, 3 - 10	12-710 190-02	6 - 4	25-161 801-49	3 - 4, 3 - 5, 6 - 3	71-590 007-83	13 - 10
12-360 061-05	3 - 17	12-710 901-22	3 - 10	25-161 801-52	3 - 4, 3 - 5, 3 - 16	71-590 007-91	13 - 3
12-360 063-05	3 - 10, 3 - 12, 4 - 3	12-710 904-12	3 - 20, 9 - 1	25-308 820-40	10 - 1	71-770 000-63	13 - 6
12-360 064-05	3 - 3, 3 - 17, 12 - 1	12-710 913-12	12 - 2	26-536 301-09	3 - 4, 3 - 5, 3 - 16, 6 - 3	91-000 621-15	3 - 14, 11 - 1
12-360 083-05	3 - 11	13-030 341-05	3 - 1	28-011 201-05	21 - 1	91-001 824-05	5 - 1
12-360 143-05	3 - 8	13-033 190-05	6 - 2, 6 - 3	28-011 202-05	21 - 1	91-004 181-05	3 - 14, 11 - 1
12-499 150-45	13 - 7	13-033 208-05	3 - 12	28-011 202-47	21 - 1	91-009 035-25	3 - 13
12-499 170-45	7 - 1	13-033 346-05	16 - 1	61-111 639-70	16 - 1	91-020 324-05	6 - 4
12-499 190-45	6 - 4, 14 - 1	13-052 085-55	3 - 6, 3 - 8	61-111 639-71	16 - 1	91-021 124-15	7 - 1
12-510 111-25	13 - 3	13-063 193-05	3 - 15, 3 - 16, 6 - 2, 6 - 3	61-111 639-76	16 - 1	91-027 289-15	18 - 1
12-510 140-45	13 - 9, 13 - 10	13-064 247-05	3 - 2	71-110 003-35	7 - 1	91-027 370-05	18 - 1
12-510 141-45	13 - 9, 13 - 10	13-068 391-05	3 - 11	71-120 006-31	13 - 6	91-027 371-12	18 - 1
12-610 190-45	3 - 7, 3 - 8, 3 - 14, 4 - 2	13-250 088-25	3 - 4	71-120 006-33	12 - 1	91-027 645-75/699	16 - 1
12-610 200-45	3 - 9, 5 - 2	13-250 097-25	3 - 5	71-130 006-39	13 - 2	91-027 975-91	21 - 1
12-610 210-45	3 - 3, 3 - 17	14-012 525-01	6 - 4	71-170 002-14	8 - 1	91-027 976-91	21 - 1
12-610 230-45	3 - 15, 3 - 16, 3 - 20, 6 - 2, 6 - 3, 9 - 1	14-012 903-01	12 - 1, 12 - 2	71-170 002-16	7 - 1	91-027 977-91	21 - 1
12-610 250-45	3 - 17	14-012 916-01	3 - 17	71-170 002-20	4 - 1, 6 - 1	91-029 692-75/792	18 - 1
12-610 280-45	3 - 18	14-016 080-01	3 - 15, 3 - 16, 6 - 2, 6 - 3	71-170 002-21	9 - 1, 9 - 2	91-056 192-25	3 - 13, 6 - 1
12-618 170-45	3 - 1	14-016 101-91	3 - 17	71-170 002-24	6 - 4	91-056 193-25	3 - 13, 6 - 1
12-618 190-45	3 - 13	14-016 151-91	3 - 6	71-370 001-08	13 - 8	91-056 197-91	6 - 1
12-618 210-45	3 - 11, 9 - 1, 9 - 2	14-016 171-91	3 - 17	71-370 001-31	4 - 2	91-056 198-21	6 - 1
12-624 200-45	4 - 1, 6 - 1	14-018 624-91	3 - 6	71-370 001-32	13 - 6	91-056 578-91	3 - 13
12-624 210-45	3 - 2	14-026 902-01	3 - 6	71-370 001-35	13 - 1	91-056 760-05	6 - 1
12-624 280-45	3 - 8	14-218 906-01	12 - 2	71-370 002-92	13 - 8	91-069 056-05	3 - 4, 3 - 5
		14-602 901-01	3 - 13	71-520 006-01	13 - 7	91-069 075-11	3 - 2

No. 序号	Seite Page Página 页号	No. 序号	Seite Page Página 页号	No. 序号	Seite Page Página 页号	No. 序号	Seite Page Página 页号
91-069 079-72/895	3 - 2	91-100 117-15	3 - 2, 4 - 1	91-171 409-12	3 - 18	91-229 080-25	15 - 1
91-069 105-25	3 - 2	91-100 270-25	3 - 12	91-171 441-01	3 - 8	91-229 081-25	15 - 1
91-069 322-01	3 - 2	91-100 281-25	3 - 13	91-171 785-05	6 - 3	91-229 123-25	15 - 1
91-069 335-72/893	18 - 1	91-100 331-15	3 - 7	91-171 811-15	3 - 7	91-229 124-25	15 - 1
91-069 371-92	5 - 2	91-100 400-15	3 - 6	91-172 676-05	3 - 18	91-229 125-25	15 - 1
91-069 434-91	3 - 2	91-105 482-05	3 - 12	91-173 967-15	7 - 1	91-229 128-25	15 - 1
91-069 483-05	5 - 1	91-106 033-15	5 - 2	91-173 968-15	7 - 1	91-229 129-25	15 - 1
91-069 484-05	5 - 1	91-107 265-05	5 - 2	91-174 002-05	12 - 2	91-229 165-70/893	18 - 1
91-069 486-05	5 - 2	91-118 570-92	3 - 6	91-174 223-05	7 - 1	91-229 180-90	13 - 8
91-069 489-12	5 - 2	91-118 683-05	3 - 13	91-174 284-01	12 - 2	91-229 287-75/699	16 - 1
91-069 490-11	5 - 1	91-118 711-05	3 - 14, 4 - 2, 5 - 1	91-174 783-05	3 - 13	91-262 061-05	3 - 17
91-069 493-11	5 - 1	91-130 865-15	7 - 1	91-174 851-05	6 - 1	91-262 161-72/698	3 - 6
91-069 496-05	5 - 1	91-161 334-25	3 - 2	91-174 879-05	3 - 13	91-262 162-75/698	3 - 1
91-069 498-11	5 - 2	91-162 578-71/698	3 - 1	91-175 203-05	3 - 18	91-262 164-12	3 - 20, 9 - 1
91-069 501-15	5 - 2	91-162 582-75/895	3 - 1	91-175 265-12	7 - 1, 12 - 1	91-262 166-91	18 - 1
91-069 554-12	3 - 14	91-162 596-25	3 - 2	91-175 354-15	7 - 1	91-262 167-05	18 - 1
91-069 562-05	3 - 2	91-162 597-05	3 - 15, 3 - 16, 6 - 2, 6 - 3	91-175 557-11	6 - 1	91-262 168-05	18 - 1
91-069 568-05	3 - 2	91-162 690-92	3 - 2	91-175 729-15	7 - 1	91-262 174-11	3 - 7
91-069 577-91	5 - 1	91-162 694-05	3 - 2	91-175 732-15	7 - 1	91-262 179-05	3 - 7
91-069 579-05	3 - 2, 4 - 1	91-162 984-05	3 - 2	91-175 806-91	7 - 1	91-262 183-75/895	3 - 1
91-069 585-25	3 - 13	91-165 685-05	6 - 2, 6 - 3	91-187 386-75/893	14 - 1	91-262 185-05	6 - 2, 6 - 3
91-069 598-11	5 - 1	91-166 452-21	3 - 13	91-187 426-70/893	14 - 1	91-262 187-15	3 - 15, 3 - 16, 6 - 2, 6 - 3
91-069 599-15	5 - 1	91-167 590-15	3 - 1	91-229 068-75/895	15 - 1	91-262 188-15	6 - 2, 6 - 3
91-069 600-15	5 - 1	91-168 347-05	3 - 18	91-229 069-75/895	15 - 1	91-262 189-91	6 - 2, 6 - 3
91-069 601-15	5 - 1	91-168 480-15	3 - 6	91-229 070-70/895	15 - 1	91-262 195-92	3 - 6
91-069 630-91	5 - 1	91-169 457-12	3 - 4	91-229 071-25	15 - 1	91-262 196-05	3 - 6
91-069 632-05	5 - 1	91-169 474-05	5 - 2	91-229 072-45	15 - 1	91-262 197-05	3 - 12
91-069 709-12	3 - 4	91-169 475-15	5 - 1	91-229 073-71/895	15 - 1	91-262 200-91	3 - 12
91-069 789-15	5 - 2	91-169 556-05	3 - 7, 3 - 8, 3 - 14	91-229 074-05	15 - 1	91-262 201-05	3 - 12
91-088 881-11	7 - 1	91-171 042-05	3 - 13	91-229 075-45	15 - 1	91-262 202-15	3 - 12
91-088 883-11	7 - 1	91-171 049-05	3 - 13	91-229 076-75/698	15 - 1	91-262 203-05	3 - 12
91-091 606-91	13 - 8	91-171 050-05	3 - 2	91-229 077-72/895	15 - 1	91-262 208-05	6 - 2, 6 - 3
91-100 076-15	3 - 14, 11 - 1	91-171 068-05	3 - 2	91-229 078-25	15 - 1	91-262 209-91	6 - 3

No. 序号	Seite Page Página 页号	No. 序号	Seite Page Página 页号	No. 序号	Seite Page Página 页号	No. 序号	Seite Page Página 页号
91-262 214-05	3 - 15, 3 - 16, 6 - 2, 6 - 3	91-262 410-92	3 - 12	91-262 680-91	3 - 20	91-262 846-05	3 - 17
91-262 218-05	3 - 10	91-262 416-91	6 - 2	91-262 686-91	3 - 14	91-262 854-91	3 - 4
91-262 225-91	6 - 2, 6 - 3	91-262 421-91	3 - 5	91-262 687-25	3 - 14	91-262 857-15	12 - 1
91-262 228-01	3 - 19	91-262 422-05	3 - 4, 3 - 5	91-262 688-91	3 - 6	91-262 860-92	12 - 1
91-262 231-72/893	3 - 11	91-262 437-05	3 - 15, 3 - 16	91-262 689-91	3 - 6	91-262 863-15	12 - 2
91-262 232-11	3 - 11	91-262 440-71/895	7 - 1	91-262 690-01	3 - 6	91-262 865-92	12 - 2
91-262 235-15	6 - 2, 6 - 3	91-262 441-75/895	7 - 1	91-262 691-91	3 - 3	91-262 871-05	12 - 2
91-262 237-91	3 - 16	91-262 442-75/895	7 - 1	91-262 692-05	3 - 3	91-262 872-91	12 - 1
91-262 250-91	3 - 16	91-262 446-15	8 - 1	91-262 751-91	3 - 3	91-262 874-75/895	12 - 1
91-262 273-05	9 - 1, 9 - 2	91-262 447-05	8 - 1	91-262 761-71/895	3 - 1	91-262 880-91	9 - 2
91-262 274-05	3 - 11	91-262 457-12	3 - 2	91-262 770-05	4 - 2	91-262 882-15	4 - 1
91-262 277-05	3 - 14	91-262 460-15	7 - 1	91-262 786-91	3 - 3	91-262 893-91	4 - 3
91-262 300-91	3 - 14	91-262 461-15	7 - 1	91-262 787-91	3 - 3	91-262 899-75/896	4 - 2
91-262 301-12	3 - 14	91-262 465-15	3 - 20, 9 - 1, 9 - 2	91-262 788-91	3 - 3	91-262 900-05	4 - 3
91-262 304-45	3 - 3	91-262 513-05	7 - 1	91-262 790-15	4 - 1	91-262 905-91	4 - 1
91-262 320-91	3 - 5	91-262 514-05	6 - 2	91-262 791-05	4 - 1	91-262 908-05	4 - 3
91-262 326-15	3 - 1	91-262 536-15	3 - 1	91-262 792-05	4 - 1	91-262 914-05	12 - 1
91-262 329-75/895	3 - 1	91-262 544-91	3 - 6	91-262 804-91	3 - 14	91-262 915-12	12 - 1
91-262 331-91	3 - 15, 3 - 16	91-262 551-91	3 - 4	91-262 805-25	3 - 14	91-262 916-91	12 - 1
91-262 336-91	3 - 4	91-262 552-12	3 - 12	91-262 806-05	3 - 14, 11 - 1	91-262 919-05	12 - 1
91-262 344-91	3 - 8	91-262 554-92	3 - 8	91-262 813-91	3 - 10	91-262 920-91	12 - 1
91-262 345-12	3 - 8	91-262 565-92	5 - 3	91-262 819-05	3 - 5	91-262 924-05	12 - 1
91-262 346-12	3 - 8	91-262 566-05	3 - 17	91-262 821-91	3 - 3	91-262 926-11	4 - 2
91-262 347-05	3 - 8	91-262 566-92	3 - 17	91-262 824-96	3 - 14	91-262 929-15	4 - 2
91-262 354-05	3 - 3	91-262 569-91	6 - 1	91-262 825-91	3 - 14	91-262 930-05	4 - 2
91-262 355-12	3 - 12	91-262 573-05	3 - 20, 9 - 1	91-262 836-01	3 - 4	91-262 931-05	4 - 2
91-262 357-75/698	20 - 1	91-262 576-05	13 - 5	91-262 837-91	3 - 4	91-262 938-15	3 - 10
91-262 360-05	3 - 15, 3 - 16, 6 - 2, 6 - 3	91-262 577-75/698	3 - 12	91-262 838-91	3 - 8	91-262 940-91	4 - 1
91-262 372-92	9 - 1, 9 - 2	91-262 578-71/698	3 - 12	91-262 839-91	3 - 8	91-262 941-91	3 - 2
91-262 376-91	3 - 16	91-262 579-15	9 - 1, 9 - 2	91-262 842-92	3 - 15, 3 - 16, 6 - 2, 6 - 3	91-262 958-15	4 - 1, 6 - 1
91-262 377-91	3 - 15, 3 - 16	91-262 677-12	3 - 20, 9 - 1	91-262 843-01	3 - 17	91-262 959-71/699	3 - 1
91-262 385-75/893	13 - 7	91-262 678-91	6 - 1	91-262 844-92	3 - 17	91-262 962-91	4 - 1
91-262 408-05	20 - 1	91-262 679-91	9 - 1	91-262 845-91	3 - 17	91-262 964-91	3 - 2

No. 序号	Seite Page Página 页号	No. 序号	Seite Page Página 页号	No. 序号	Seite Page Página 页号	No. 序号	Seite Page Página 页号
91-262 983-75/699	12 - 1	91-264 212-91	5 - 1	91-265 065-05	6 - 3	95-774 409-25	11 - 1
91-262 985-25	3 - 1	91-264 213-12	5 - 1	91-265 189-05	3 - 14	95-774 419-25	11 - 1
91-262 986-91	3 - 15, 3 - 16, 6 - 2, 6 - 3	91-264 214-05	5 - 1	91-265 198-15	3 - 7	95-774 464-25	3 - 13
91-262 987-91	3 - 16	91-264 215-05	10 - 1	91-266 397-01	3 - 13	95-774 465-25	3 - 13
91-262 988-91	6 - 3	91-264 222-15	3 - 17	91-266 856-25	16 - 1	95-774 466-91	3 - 13
91-262 989-91	6 - 2	91-264 226-75/895	12 - 1	91-268 076-15	3 - 16, 6 - 3	95-774 467-05	3 - 13
91-264 132-75/895	5 - 3	91-264 233-15	3 - 1	91-268 668-75/895	13 - 3, 13 - 4	95-774 508-91	3 - 17
91-264 133-75/895	5 - 1	91-264 236-01	12 - 2	91-268 671-70/895	13 - 3, 13 - 4	95-774 524-91	11 - 1
91-264 134-91	5 - 2	91-264 240-05	6 - 2, 6 - 3	91-290 113-91	13 - 9, 13 - 10	95-774 525-91	11 - 1
91-264 136-05	5 - 1	91-264 249-91	12 - 2	91-290 733-91	13 - 9, 13 - 10	95-784 321-91	12 - 1
91-264 139-72/895	5 - 2	91-264 250-05	12 - 2	91-291 458-91	13 - 9, 13 - 10	95-784 333-91	13 - 1
91-264 140-15	5 - 1	91-264 251-71/895	12 - 1	91-700 335-25	3 - 1, 5 - 3	95-784 334-91	11 - 1
91-264 141-91	5 - 3	91-264 254-16	3 - 14	91-700 785-15	3 - 18	95-784 337-91	10 - 1
91-264 144-75/895	5 - 1	91-264 255-91	3 - 18	91-700 996-15	3 - 13	99-069 722-01	3 - 4
91-264 146-05	5 - 1	91-264 258-91	3 - 14	91-701 179-15	3 - 14	99-133 220-01	3 - 4
91-264 147-71/895	5 - 2	91-264 259-04/001	3 - 18	91-701 346-15	5 - 2	99-134 369-91	10 - 1
91-264 154-25	3 - 14	91-264 293-91	3 - 9	91-701 391-15	5 - 2	99-134 452-91	10 - 1
91-264 156-05	4 - 3	91-264 299-91	3 - 15	95-600 649-05	7 - 1	99-135 161-85	3 - 11
91-264 166-01	12 - 2	91-264 300-91	3 - 15	95-665 735-91	21 - 1	99-136 546-91	14 - 1
91-264 167-05	12 - 2	91-264 301-91	3 - 10	95-669 358-05	3 - 16, 6 - 3	99-136 854-55	13 - 9, 13 - 10
91-264 170-01	12 - 2	91-264 304-05	3 - 10	95-774 310-91	6 - 4	99-137 151-45	3 - 13
91-264 173-01	12 - 2	91-264 306-12	3 - 10	95-774 311-01	6 - 4	99-137 186-05	3 - 15, 3 - 16
91-264 186-91	4 - 2	91-264 310-91	3 - 15	95-774 313-91	6 - 4	99-137 187-15	3 - 15, 3 - 16
91-264 187-91	4 - 2	91-264 338-15	6 - 2, 6 - 3	95-774 314-01	6 - 4	99-137 188-15	3 - 15, 3 - 16
91-264 189-71/896	4 - 3	91-264 339-15	3 - 7	95-774 317-05	6 - 4	99-137 190-05	3 - 15, 3 - 16
91-264 192-91	13 - 6	91-264 340-11	3 - 7	95-774 318-01	6 - 4	99-137 191-05	3 - 15, 3 - 16
91-264 193-11	13 - 6	91-264 341-91	3 - 7	95-774 324-11	6 - 4	99-137 192-05	3 - 15, 3 - 16
91-264 196-05	13 - 6	91-264 355-91	3 - 10	95-774 325-02	3 - 17	99-137 193-05	3 - 15, 3 - 16
91-264 197-05	13 - 6	91-264 357-05	3 - 13	95-774 325-05	3 - 17	99-137 194-05	3 - 15, 3 - 16
91-264 198-15	10 - 1	91-264 358-05	3 - 13	95-774 327-91	3 - 1	99-137 196-05	13 - 7
91-264 200-75/895	12 - 2	91-264 364-05	13 - 5	95-774 361-05	11 - 1	99-137 247-45	3 - 1
91-264 201-71/895	12 - 2	91-264 365-91	13 - 5	95-774 407-91	11 - 1	99-137 341-01	4 - 2
91-264 207-71/895	10 - 1	91-264 769-02	4 - 2	95-774 408-91	11 - 1	99-137 355-91	10 - 1

No. 序号	Seite Page Página 页号	No. 序号	Seite Page Página 页号	No. 序号	Seite Page Página 页号	No. 序号	Seite Page Página 页号
99-137 405-05	3 - 15, 3 - 16						

# PFAFF

## 1181

## 1183

Unterklassen-Ausstattung

Subclass parts

Composición de las subclases

子机型-设备

## 1181-D

## 1183-D

# 23.01 Nähwerkzeuge<sup>▲</sup> Gauge parts Organos de costura 缝纫工具

PFAFF 1181;1181-D  
PFAFF 1181-SPR;1181-D-SRP

-8/11

Für allgemeine Näharbeiten.  
Standardform des Teilesatzes.  
(Zum Nähen mittlerer  
Materialien.)

For ordinary sewing operations.  
Standard part set.  
(for sewing medium-weight  
materials.)

Para trabajos de costura en general.  
Juego de piezas estándar.  
(para coser materiales semiligeros.)

适用于一般性缝纫工作。  
套件的标准型式。  
(用于中偏厚料的缝纫)

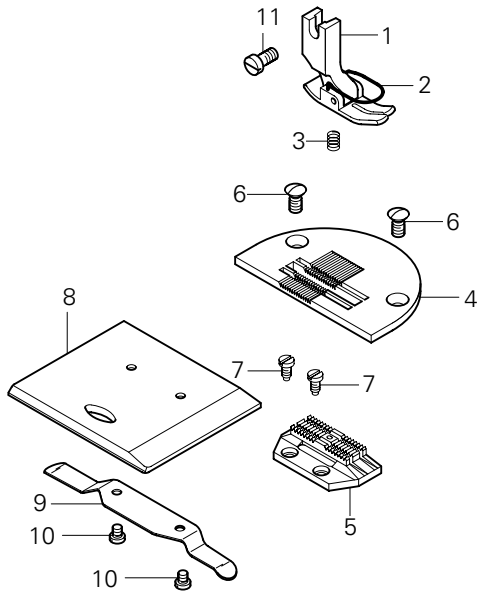

Pos.-Nr. Item No. 序号	Ausführung Model Tipo 款式	Stichlänge Stitch length Largo de puntada 针距	Teile-Nr. Part No. 零件号
1 - 10	B♦	4,5	91-202 308-91
1 - 3	B♦	4,5	91-154 804-21
2			91-154 744-05 <span style="border: 1px solid black; padding: 0 2px;">3/1</span>
3			91-154 518-05
4	B♦	4,5	91-150 671-25
5	B♦	4,5	91-059 816-05
6			91-264 154-25
7			91-701 179-15
8 - 10			91-262 686-91
8			91-262 687-25
9			91-004 181-05
10			91-100 076-15
11			11-108 174-15

# 23.01 Nähwerkzeuge<sup>▲</sup> Gauge parts Organos de costura 缝纫工具

PFAFF 1181

-8/13

Für allgemeine Näharbeiten.  
Standardform des Teilesatzes.  
(Zum Nähen mittelschwerer  
Materialien.)

For ordinary sewing operations.  
Standard part set.  
(for sewing medium-heavy  
materials.)

Para trabajos de costura en general.  
Juego de piezas estándar.  
(para coser materiales semipesados.)

适用于一般性缝纫工作。  
套件的标准型式。  
(用于中偏厚料的缝纫)

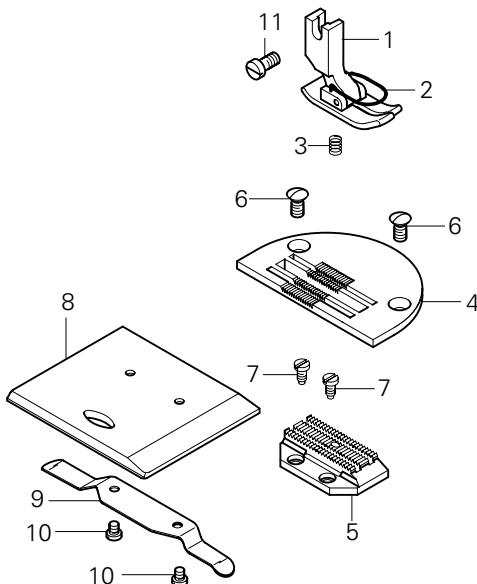

Pos.-Nr. Item No. 序号	Ausführung Model Tipo 款式	Stichlänge Stitch length Largo de puntada 针距	Teile-Nr. Part No. 零件号
1 - 10	C♦	6,0	91-202 310-93/001
1 - 3	C♦	6,0	91-154 838-23/001
2			91-154 744-05 <span style="border: 1px solid black; padding: 0 2px;">3/1</span>
3			91-154 518-05
4	C♦	6,0	91-150 672-25
5	C♦	6,0	91-059 961-05
6			91-264 154-25
7			91-701 179-15
8 - 10			91-262 686-91
8			91-262 687-25
9			91-004 181-05
10			91-100 076-15
11			11-108 174-15



-8/92

Für allgemeine Näharbeiten  
mittels Brücken-Teilesatz..  
(Zum Nähen mittlerer  
Materialien.)

For ordinary sewing operations  
with bridge-type part set.  
(for sewing medium-weight  
materials.)

Para trabajos de costura en general  
juego de piezas en puente.  
(para coser materiales semiligeros.)

适用于借助桥形杆组件的  
一般性缝纫工作。  
(用于中厚料的缝纫)

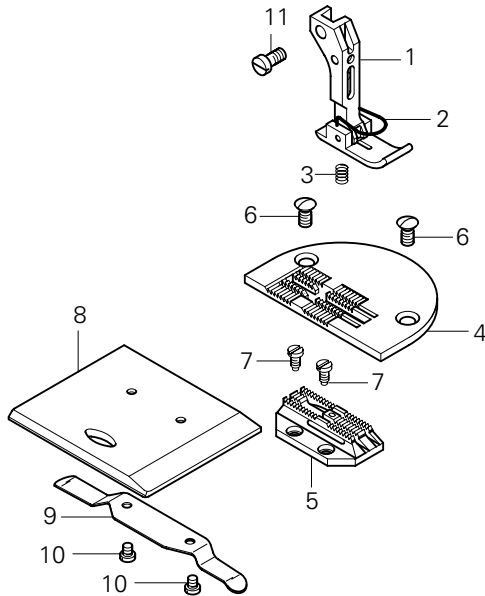

Pos.-Nr. Item No. N° de pos. 序号	Ausführung Model Tipo 款式	Stichlänge Stitch length Largo de puntada 针距	Teile-Nr. Part No. N° de pieza 零件号
1 - 10	B♦	4,5	91-202 453-93/001
1 - 3	B♦	4,5	91-154 832-21
2			91-054 894-05 [3/1]
3			91-154 518-05
4	B♦	4,5	91-150 673-25
5	B♦	4,5	91-059 505-05
6			91-264 154-25
7			91-701 179-15
8 - 10			91-262 686-91
8			91-262 687-25
9			91-004 181-05
10			91-100 076-15
11			11-108 174-15

-34/11

Zum Nähen besonders feiner  
Stoffe.

For stitching delicate fabrics.

Para géneros muy finos mediante.

适用于缝纫特薄材料。

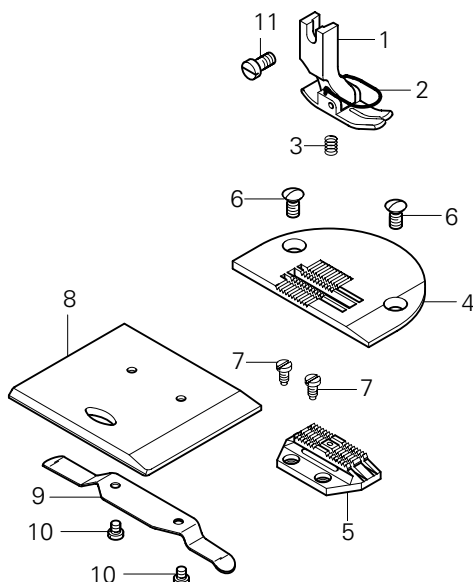

Pos.-Nr. Item No. N° de pos. 序号	Ausführung Model Tipo 款式	Stichlänge Stitch length Largo de puntada 针距	Teile-Nr. Part No. N° de pieza 零件号
1 - 10	A♦	3,0	91-202 450-91
1 - 3	A♦	3,0	91-154 804-21
2			91-154 744-05 [3/1]
3			91-154 518-05
4	A♦	3,0	91-150 819-25
5	A♦	3,0	91-059 496-05
6			91-264 154-25
7			91-701 179-15
8 - 10			91-262 686-91
8			91-262 687-25
9			91-004 181-05
10			91-100 076-15
11			11-108 174-15

# 23.01 Nähwerkzeuge<sup>▲</sup> Gauge parts Organos de costura 缝纫工具

PFAFF 1181-948/51  
PFAFF 1181- D-948/51

-34/92

Zum Nähen besonders feiner Stoffe mittels Brücken-Teilesatz.

For stitching delicate fabrics with bridge-type part set.

Para géneros muy finos mediante juego de piezas en puente.

适用于借助桥形杆组件缝纫特薄材料。

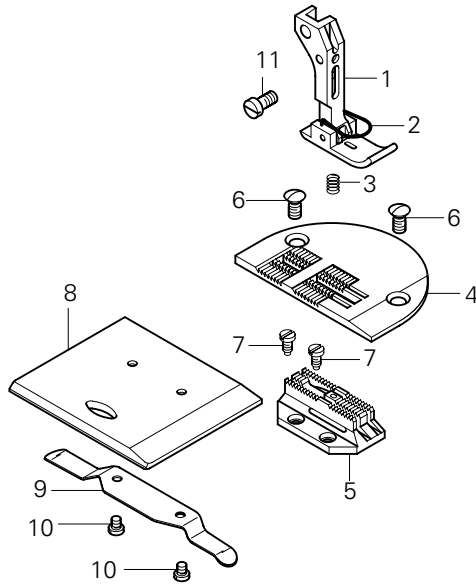

Pos.-Nr. Item No. N° de pos. 序号	Ausführung Model Tipo 款式	Stichlänge Stitch length Largo de puntada 针距	Teile-Nr. Part No. N° de pieza 零件号
1 - 10	A <sup>▲</sup>	3,0	91-202 454-93/001
1 - 3	A <sup>▲</sup>	3,0	91-154 830-21
2			91-054 894-05 <span style="border: 1px solid black; padding: 0 2px;">3/1</span>
3			91-154 518-05
4	A <sup>▲</sup>	3,0	91-150 764-25
5	A <sup>▲</sup>	3,0	91-059 504-05
6			91-264 154-25
7			91-701 179-15
8 - 10			91-262 686-91
8			91-262 687-25
9			91-004 181-05
10			91-100 076-15
11			11-108 174-15

# 23.01 Nähwerkzeuge<sup>▲</sup> Gauge parts Organos de costura 缝纫工具

PFAFF 1181  
PFAFF 1181- D

-731/01-8/11

Arbeitsgang  
Operation  
Opération  
工序

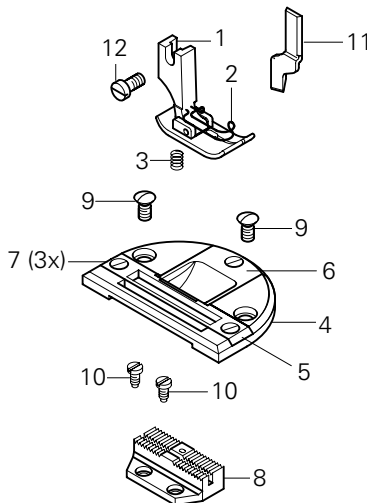
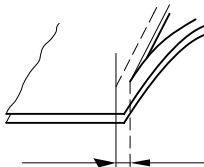

Pos.-Nr. Item No. N° de pos. 序号	Ausführung Model Tipo 款式	Stichlänge Stitch length Largo de puntada 针距	Schneidabstand Trimming margin Margen de corte 切边距离	Teile-Nr. Part No. N° de pieza 零件号
1 - 11		4,5	4,0	91-202 363-93/003
		4,5	4,5	91-202 363-93/004
		4,5	5,0	91-202 363-93/001
		4,5	6,0	91-202 363-93/005
		4,5	7,0	91-202 363-93/006
1 - 3		4,5	4,0	91-154 792-03/005
		4,5	4,5	91-154 792-03/006
		4,5	5,0	91-154 792-03/001
		4,5	6,0	91-154 792-03/007
		4,5	7,0	91-154 792-03/008
2			91-154 797-05 <span style="border: 1px solid black; padding: 0 2px;">3/1</span>	
3			91-154 518-05	
4 - 7		4,5	4,0	91-150 676-93/002
		4,5	4,5	91-150 676-93/003
		4,5	5,0	91-150 676-93/001
		4,5	6,0	91-150 676-93/004
		4,5	7,0	91-150 676-93/005
4			91-150 677-05	
5		4,5	4,0	91-048 716-03/001
		4,5	4,5	91-048 716-03/002
		4,5	5,0	91-048 716-03/003
		4,5	6,0	91-048 716-03/005
		4,5	7,0	91-048 716-03/007
6		4,5	4,0	91-048 703-04/004
		4,5	4,5	91-048 703-04/005
		4,5	5,0	91-048 703-04/006
		4,5	6,0	91-048 703-04/008
		4,5	7,0	91-048 703-04/010
7			91-000 730-25	
8		4,5	4,0	91-059 833-047/002
		4,5	4,5	91-059 833-047/004
		4,5	5,0	91-059 833-047/006
		4,5	6,0	91-059 833-047/008
		4,5	7,0	91-059 833-047/010
9			91-264 154-25	
10			91-701 179-15	
11			91-069 595-04/002	
12			11-108 174-15	

-8/31

Für allgemeine Näharbeiten.  
Standardform des Teilesatzes.  
(Zum Nähen mittlerer  
Materialien.)

For ordinary sewing operations.  
Standard part set.  
(for sewing medium-weight  
materials.)

Para trabajos de costura en general.  
Juego de piezas estándar.  
(para coser materiales semiligeros.)

适用于一般性缝纫工作。  
套件的标准型式。  
(用于中厚料的缝纫)

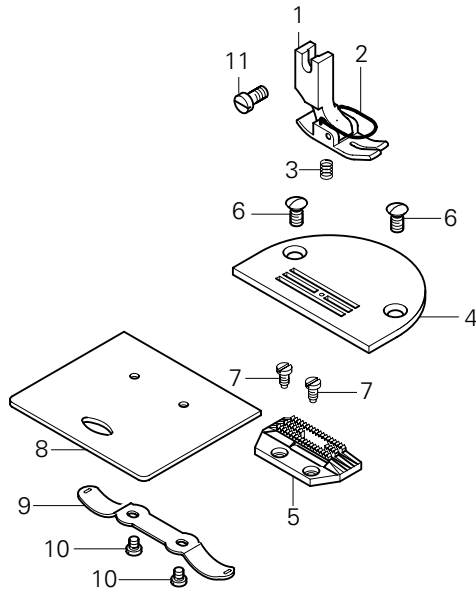

Pos.-Nr. Item No. N° de pos. 序号	Ausführung Model Tipo 款式	Stichlänge Stitch length Largo de puntada 针距	Teile-Nr. Part No. N° de pieza 零件号
1 - 10	B♦	4,5	91-202 356-93/001
1 - 3	B♦	4,5	91-154 807-21
2			91-154 744-05 [3/1]
3			91-154 518-05
4	B♦	4,5	91-150 694-24/001
5	B♦	4,5	91-059 968-05
6			91-264 154-25
7			91-701 179-15
8 - 10			91-262 804-91
8			91-262 805-25
9			91-262 806-05
10			91-000 621-15
11			11-108 174-15

-8/33

Für allgemeine Näharbeiten.  
Standardform des Teilesatzes.  
(Zum Nähen mittelschwerer  
Materialien.)

For ordinary sewing operations.  
Standard part set.  
(for sewing medium-heavy  
materials.)

Para trabajos de costura en general.  
Juego de piezas estándar.  
(para coser materiales semipesados.)

适用于一般性缝纫工作。  
套件的标准型式。  
(用于中偏厚料的缝纫)

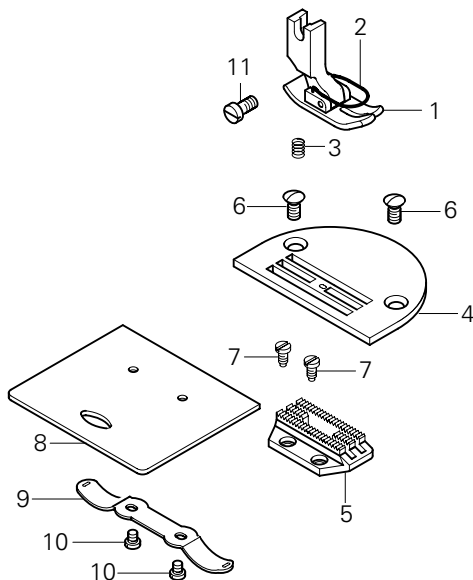

Pos.-Nr. Item No. N° de pos. 序号	Ausführung Model Tipo 款式	Stichlänge Stitch length Largo de puntada 针距	Teile-Nr. Part No. N° de pieza 零件号
1 - 10	C♦	6,0	91-202 357-93/001
1 - 3	C♦	6,0	91-154 845-23/001
2			91-154 744-05 [3/1]
3			91-154 518-05
4	C♦	6,0	91-150 693-25
5	C♦	6,0	91-059 967-05
6			91-264 154-25
7			91-701 179-15
8 - 10			91-262 804-91
8			91-262 805-25
9			91-262 806-05
10			91-000 621-15
11			11-108 174-15

-8/44

Für Stepparbeiten an Schuhschäften und sonstigen Lederwaren mittels Rollfuß

For sewing operations on shoe uppers and other leather articles; machine equipped with roller presser.

Para trabajos de apurado en cortes de calzado y demás artículos de cuero mediante pie rodante. 适用于滚轮压脚在鞋帮和其它皮料上的珩缝针绣工作。

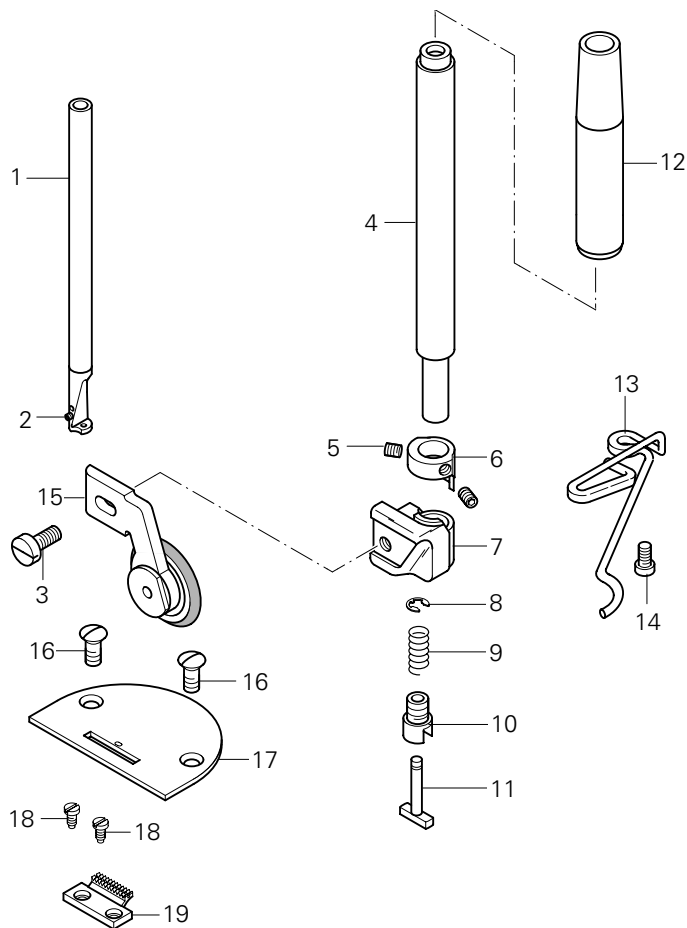

Pos.-Nr. Item No. 序号	Ausführung Model 款式	Stichlänge Stitch length Largo de puntada 针距	Teile-Nr. Part No. 零件号
1 - 9	B♦	4,5	91-202 358-93/002
1	B♦	4,5	91-051 155-93/001
2	B♦	4,5	91-150 695-24/002
3	B♦	4,5	91-059 969-04/002
4			91-264 154-25
5			91-701 179-15
6 - 9			91-262 804-91
7			91-262 805-25
8			91-262 806-05
9			91-000 621-15
10			91-700 717-15
11 - 12			91-262 565-92

Pos.-Nr. Item No. 序号	Ausführung Model 款式	Stichlänge Stitch length Largo de puntada 针距	Teile-Nr. Part No. 零件号
12			11-330 085-15
13			91-171 076-01
14			91-700 388-15
15			91-169 322-15
16			91-169 323-15
17			12-640 070-55
18			91-025 376-05
19			91-700 409-15
20			91-025 374-05
21			91-171 557-05
22			91-262 520-25
23			11-132 172-15

-8/93

Für allgemeine Näharbeiten.  
Standardform des Teilesatzes.  
(Zum Nähen mittlerer  
Materialien.)

For ordinary sewing operations.  
Standard part set.  
(for sewing medium-weight  
materials.)

Para trabajos de costura en general.  
Juego de piezas estándar.  
(para coser materiales semiligeros.)

适用于借助桥形杆组件的  
一般性缝纫工作。  
(用于中厚料的缝纫)

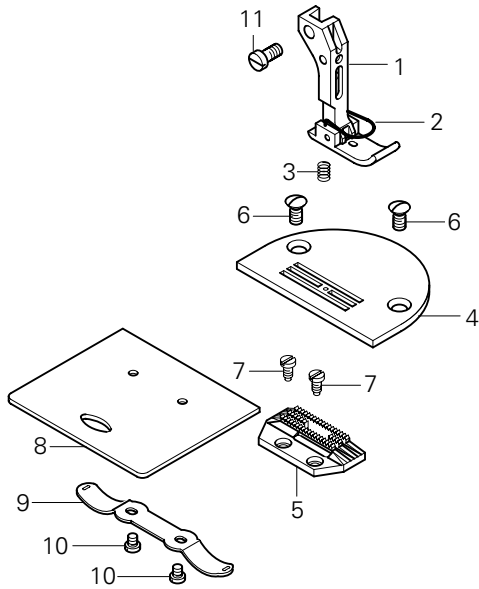

Pos.-Nr. Item No. 序号	Ausführung Model Typo 款式	Stichlänge Stitch length Largo de puntada 针距	Teile-Nr. Part No. 零件号
1 - 10	B♦	4,5	91-202 391-93/001
1 - 3	B♦	4,5	91-154 832-21
2			91-054 894-05 [3/1]
3			91-154 518-05
4	B♦	4,5	91-150 694-24/001
5	B♦	4,5	91-059 968-05
6			91-264 154-25
7			91-701 179-15
8 - 10			91-262 804-91
8			91-262 805-25
9			91-262 806-05
10			91-000 621-15
11			11-108 174-15

-34/31

Zum Nähen besonders feiner  
Stoffe.

For stitching delicate fabrics.

Para géneros muy finos mediante.

适用于缝纫特薄材料。

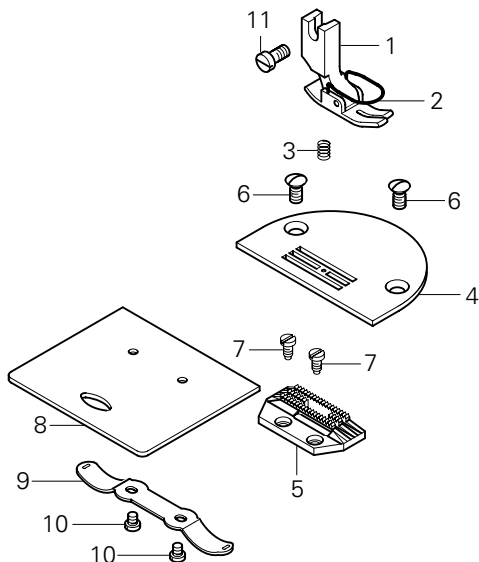

Pos.-Nr. Item No. 序号	Ausführung Model Typo 款式	Stichlänge Stitch length Largo de puntada 针距	Teile-Nr. Part No. 零件号
1 - 10	A♦	3,0	91-202 448-93/001
1 - 3	A♦	3,0	91-154 843-23/001
2			91-154 744-05 [3/1]
3			91-154 518-05
4	A♦	3,0	91-150 820-25
5	A♦	3,0	91-059 497-05
6			91-264 154-25
7			91-701 179-15
8 - 10			91-262 804-91
8			91-262 805-25
9			91-262 806-05
10			91-000 621-15
11			11-108 174-15

# 23.02 Nähwerkzeuge<sup>▲</sup> Gauge parts Organos de costura 缝纫工具

PFAFF 1183-948/51  
PFAFF 1183- D-948/51

-34/93

Zum Nähen besonders feiner Stoffe.

For stitching delicate fabrics.

Para géneros muy finos mediante.

适用于缝纫特薄材料。

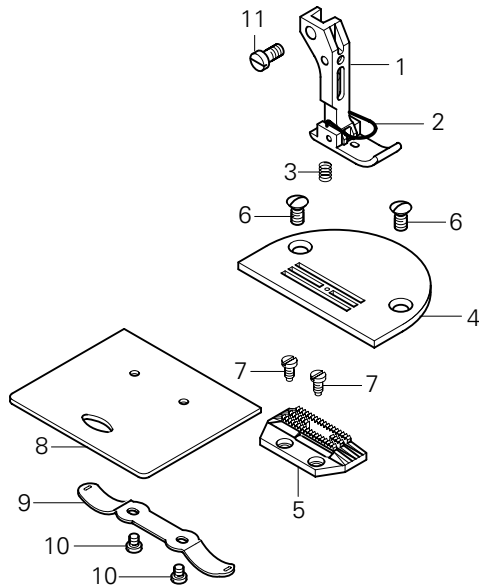

Pos.-Nr. Item No. № de pos. 序号	Ausführung Model Tipo 款式	Stichlänge Stitch length Largo de puntada 针距	Teile-Nr. Part No. № de pieza 零件号
1 - 10	A♦	3,0	91-202 449-93/001
1 - 3	A♦	3,0	91-154 834-23/001
2			91-054 894-05 <span style="border: 1px solid black; padding: 0 2px;">3/1</span>
3			91-154 518-05
4	A♦	3,0	91-150 820-25
5	A♦	3,0	91-059 497-05
6			91-264 154-25
7			91-701 179-15
8 - 10			91-262 804-91
8			91-262 805-25
9			91-262 806-05
10			91-000 621-15
11			11-108 174-15

# 23.02 Nähwerkzeuge<sup>▲</sup> Gauge parts Organos de costura 缝纫工具

PFAFF 1183  
PFAFF 1183- D

-731/01-8/31

Arbeitsgang  
Operation  
Opéracion  
工序

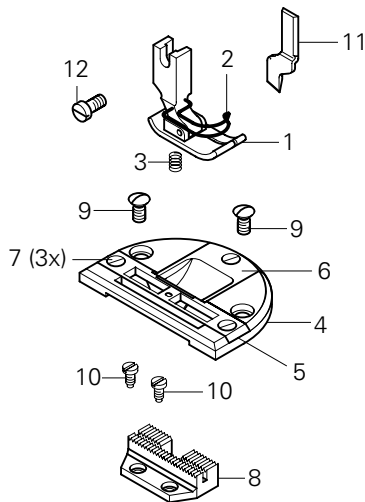
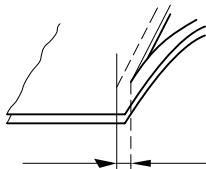

Pos.-Nr. Item No. № de pos. 序号	Ausführung Model Tipo 款式	Stichlänge Stitch length Largo de puntada 针距	Schneidabstand Trimming margin Margen de corte 切边距离	Teile-Nr. Part No. № de pieza 零件号
1 - 11	B♦	4,5	5,0	91-202 364-93/001
	B♦	4,5	7,0	91-202 364-93/002
1 - 3	B♦	4,5	4,0	91-154 794-03/005
	B♦	4,5	4,5	91-154 794-03/006
	B♦	4,5	5,0	91-154 794-03/001
	B♦	4,5	6,0	91-154 794-03/007
	B♦	4,5	7,0	91-154 794-03/008
2				91-154 797-05 <span style="border: 1px solid black; padding: 0 2px;">3/1</span>
3				91-154 518-05
4 - 7	B♦	4,5	5,0	91-150 680-93/001
	B♦	4,5	7,0	91-150 680-93/002
4				91-150 677-05
5	B♦	4,5	4,0	91-048 705-03/012
	B♦	4,5	4,5	91-048 705-03/013
	B♦	4,5	5,0	91-048 705-03/014
	B♦	4,5	6,0	91-048 705-03/016
	B♦	4,5	7,0	91-048 705-03/025
6	B♦	4,5	4,0	91-048 703-04/004
	B♦	4,5	4,5	91-048 703-04/005
	B♦	4,5	5,0	91-048 703-04/006
	B♦	4,5	6,0	91-048 703-04/008
	B♦	4,5	7,0	91-048 703-04/010
7				91-000 730-25
8	B♦	4,5	4,0	91-059 464-04/009
	B♦	4,5	4,5	91-059 464-04/010
	B♦	4,5	5,0	91-059 464-04/011
	B♦	4,5	6,0	91-059 464-04/012
	B♦	4,5	7,0	91-059 464-04/013
9				91-264 154-25
10				91-701 179-15
11				91-169 395-04/002
12				11-108 174-15



**PFAFF**